

DENISON HYDRAULICS T6E - T6EM - T6EP

vane-type single pump / flügelzellen-Einzelpumpe
pompe simple à palettes / pompa semplice a palette
tipo bomba de paletas simple
service information



Publ. S1 - ML0504 - A 03 / 2003 / FB

Replace : S1 - ML 054 - B

L25 - 10504 - 1

DENISON | **Hydraulics**

Recommended repair kits and assy's are bold printed
 Empfohlene Austausch - Baugruppen sind fett gedruckt
 Les pochettes de rechange recommandées sont imprimées en caractères gras
 I kit di ricambio consigliati sono indicati in grassetto
 Los juegos de reparacion recomendados y los conjuntos, estan en negrita

	Item - Pos. - Réf. - Pos.	
	24	
Mounting torque	187 Nm	138 ft.lbs
Anziehdrehmoment		
Couple de serrage		
Coppia di serraggio		
Par de apriete		

T6E INDUSTRIAL

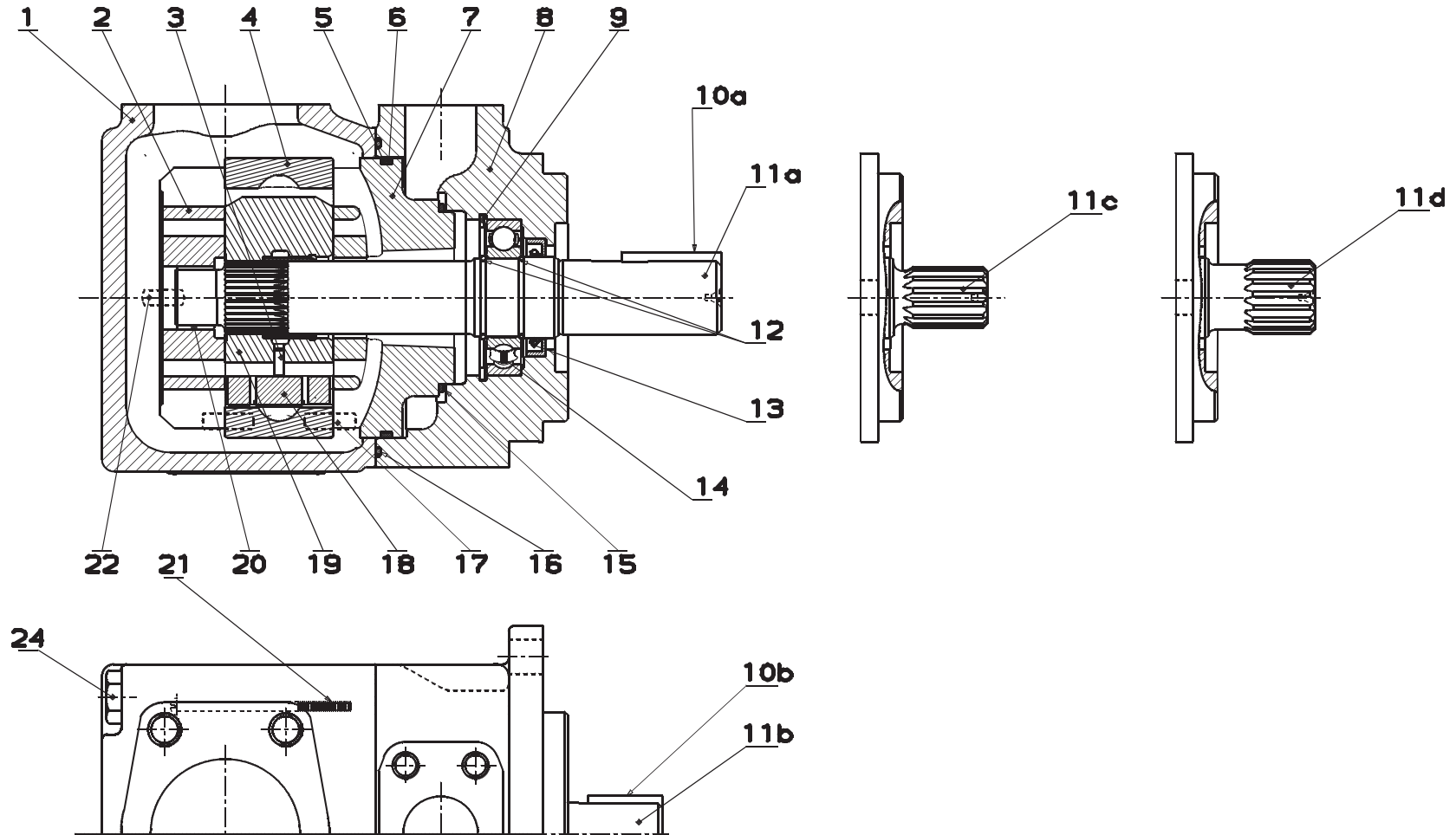

Recommended repair kits and assy's are bold printed
 Empfohlene Austausch - Baugruppen sind fett gedruckt
 Les pochettes de rechange recommandées sont imprimées en caractères gras
 I kit di ricambio consigliati sono indicati in grassetto
 Los juegos de reparacion recomendados y los conjuntos, estan en negrita

	Item - Pos. - Réf. - Pos.	
	24	
Mounting torque	187 Nm	138 ft.lbs
Anziehdrehmoment		
Couple de serrage		
Coppia di serraggio		
Par de apriete		

T6EM MOBILE

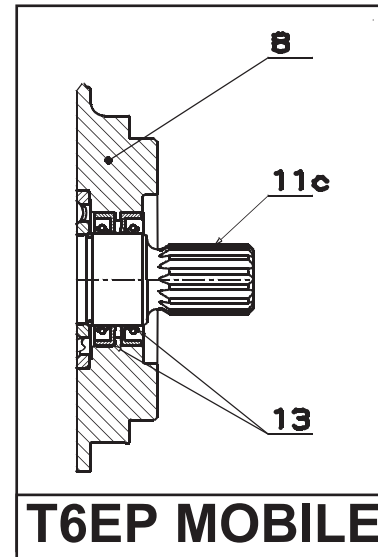
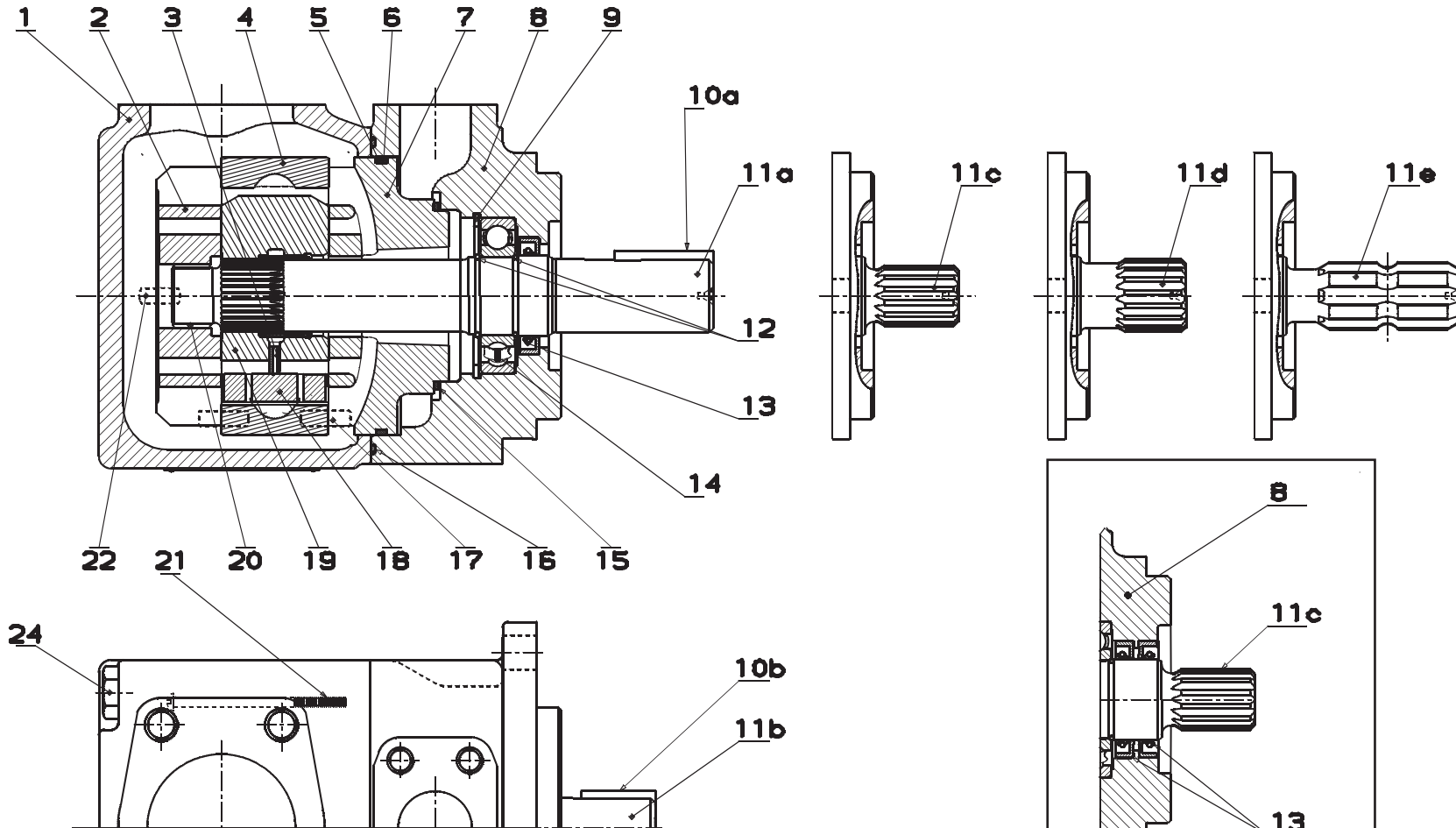

T6EP MOBILE

Item Pos. Ref. Pos.	Description Descrizione	Benennung Descripción	Description		Part N° Teil Nr. Code N° Cod. N° Referencia T6E	Part N° Teil Nr. Code N° Cod. N° Referencia T6EM - T6EP	Qty Stück Qté Q.tà Cant.
1	Housing (standard) <i>Corpo (standard)</i>	Gehäuse (Standard) <i>Cuerpo (estandar)</i>	Carter (standard)		034.70247	034.70247	1
2	Port plate-rear C.C.W. <i>Piatto distributore post. antioraria</i>	Steuerplatte Linkslauf <i>Plato distribuidor trasero giro I</i>	Plaque arrière rotation gauche	AH	034.59083	034.59083	1
	Port plate-rear C.W. <i>Piatto distributore post. oraria</i>	Steuerplatte Rechtslauf <i>Plato distribuidor trasero giro D</i>	Plaque arrière rotation droite	AJ	034.59082	034.59082	1
3	Pin-vane holdout <i>Pistoncino di sostentamento</i>	Stössel <i>Espiga empuje paleta</i>	Poussoir de palette	A	034.59161	034.70259	12
4	Cam ring 042 <i>Anello camma 042</i>	Hubring 042 <i>Aro volumetrico 042</i>	Came 042	A	034.66899	034.66899	1
	Cam ring 045 <i>Anello camma 045</i>	Hubring 045 <i>Aro volumetrico 045</i>	Came 045	A	034.59164	034.59164	1
	Cam ring 050 <i>Anello camma 050</i>	Hubring 050 <i>Aro volumetrico 050</i>	Came 050	A	034.66744	034.66744	1
	Cam ring 052 <i>Anello camma 052</i>	Hubring 052 <i>Aro volumetrico 052</i>	Came 052	A	034.59165	034.59165	1
	Cam ring 062 <i>Anello camma 062</i>	Hubring 062 <i>Aro volumetrico 062</i>	Came 062	A	034.59166	034.59166	1
	Cam ring 066 <i>Anello camma 066</i>	Hubring 066 <i>Aro volumetrico 066</i>	Came 066	A	034.59167	034.59167	1
	Cam ring 072 <i>Anello camma 072</i>	Hubring 072 <i>Aro volumetrico 072</i>	Came 072	A	034.66736	034.66736	1
5	Back-up ring <i>Anello anti-estrusione</i>	Stützring <i>Anillo</i>	Bague anti-extrusion	AB	618.00012.3	618.00012.3	1
6	Sq. section seal <i>Guarnizione</i>	Dichtring <i>Junta seccion cuadrada</i>	Joint section carrée	AB	691.10253	691.10253	1
7	Port plate-pressure C.C.W. <i>Piatto distributore anter. antioraria</i>	Steuerplatte Linkslauf <i>Plato distribuidor-presión giro I</i>	Plaque pression rotation gauche	A	034.59160	034.59160	1
	Port plate-pressure C.W. <i>Piatto distributore anter. oraria</i>	Steuerplatte Rechtslauf <i>Plato distribuidor-presión giro D</i>	Plaque pression rotation droite	A	034.59159	034.59159	1
8	Mounting cap (standard) (T6E-T6EM) <i>Coperchio (standard) (T6E-T6EM)</i>	Deckel (Standard) (T6E-T6EM) <i>Tapa de montage (estandar) (T6E-T6EM)</i>	Chapeau de montage (standard) (T6E-T6EM)		034.70249	034.70249	1
	Mounting cap (standard) (T6EP) <i>Coperchio (standard) (T6EP)</i>	Deckel (Standard) (T6EP) <i>Tapa de montage (estandar) (T6EP)</i>	Chapeau de montage (standard) (T6EP)			034.66745	1
9	Retaining ring <i>Anello elastico</i>	Sicherungsring <i>Anillo de retención</i>	Circlips		356.30315	356.30315	1
10a	Key (code 1) <i>Chiavetta (codice 1)</i>	Paßfeder (Typ 1) <i>Chaveta (codigo 1)</i>	Clavette (code 1)	C	034.70330	034.70330	1
10b	Key (code 2) <i>Chiavetta (codice 2)</i>	Paßfeder (Typ 2) <i>Chaveta (codigo 2)</i>	Clavette (code 2)	D	034.49676	034.49676	1
11a	Shaft (keyed) (code 1) <i>Albero a chiavetta (codice 1)</i>	Paßfederwelle (Typ 1) <i>Eje chaveteado (codigo 1)</i>	Arbre à clavette (code 1)	C	034.71076	034.71076	1

Item Pos. Ref. Pos.	Description <i>Descrizione</i>	Benennung <i>Descripcion</i>	Description	Part N° Teil Nr. Code N° Cod. N° Referencia T6E	Part N° Teil Nr. Code N° Cod. N° Referencia T6EM - T6EP	Qty Stück Qté Q.tà Cant.
	REPAIR KIT <i>KIT DI RICAMBIO</i>	AUSTAUSCH-BAUGRUPPEN <i>CONJUNTO REPARACION</i>	POCHETTES RECHANGES			
A	Cart. and plate ass'y 042 C.W. <i>Ins. cart. 042 oraria</i>	Pumpeneinheit 042 Rechtslauf <i>Conjunto cart. y platos 042 giro d.</i>	Cart. et plaque ass. 042 rot. d.	S24.49388	S24.49392	1
A	Cart. and plate ass'y 042 C.C.W. <i>Ins. cart. 042 antioraria</i>	Pumpeneinheit 042 Linkslauf <i>Conjunto cart. y platos 042 giro i.</i>	Cart. et plaque ass. 042 rot. g.	S24.49389	S24.49393	1
A	Cart. and plate ass'y 045 C.W. <i>Ins. cart. 045 oraria</i>	Pumpeneinheit 045 Rechtslauf <i>Conjunto cart. y platos 045 giro d.</i>	Cart. et plaque ass. 045 rot. d.	S24.10177	S24.40014	1
A	Cart. and plate ass'y 045 C.C.W. <i>Ins. cart. 045 antioraria</i>	Pumpeneinheit 045 Linkslauf <i>Conjunto cart. y platos 045 giro i.</i>	Cart. et plaque ass. 045 rot. g.	S24.10178	S24.40015	1
A	Cart. and plate ass'y 050 C.W. <i>Ins. cart. 050 oraria</i>	Pumpeneinheit 050 Rechtslauf <i>Conjunto cart. y platos 050 giro d.</i>	Cart. et plaque ass. 050 rot. d.	S24.40645	S24.40767	1
A	Cart. and plate ass'y 050 C.C.W. <i>Ins. cart. 050 antioraria</i>	Pumpeneinheit 050 Linkslauf <i>Conjunto cart. y platos 050 giro i.</i>	Cart. et plaque ass. 050 rot. g.	S24.40766	S24.40768	1
A	Cart. and plate ass'y 052 C.W. <i>Ins. cart. 052 oraria</i>	Pumpeneinheit 052 Rechtslauf <i>Conjunto cart. y platos 052 giro d.</i>	Cart. et plaque ass. 052 rot. d.	S24.10179	S24.40016	1
A	Cart. and plate ass'y 052 C.C.W. <i>Ins. cart. 052 antioraria</i>	Pumpeneinheit 052 Linkslauf <i>Conjunto cart. y platos 052 giro i.</i>	Cart. et plaque ass. 052 rot. g.	S24.10180	S24.40017	1
A	Cart. and plate ass'y 062 C.W. <i>Ins. cart. 062 oraria</i>	Pumpeneinheit 062 Rechtslauf <i>Conjunto cart. y platos 062 giro d.</i>	Cart. et plaque ass. 062 rot. d.	S24.10181	S24.40018	1
A	Cart. and plate ass'y 062 C.C.W. <i>Ins. cart. 062 antioraria</i>	Pumpeneinheit 062 Linkslauf <i>Conjunto cart. y platos 062 giro i.</i>	Cart. et plaque ass. 062 rot. g.	S24.10182	S24.40019	1
A	Cart. and plate ass'y 066 C.W. <i>Ins. cart. 066 oraria</i>	Pumpeneinheit 066 Rechtslauf <i>Conjunto cart. y platos 066 giro d.</i>	Cart. et plaque ass. 066 rot. d.	S24.10183	S24.40020	1
A	Cart. and plate ass'y 066 C.C.W. <i>Ins. cart. 066 antioraria</i>	Pumpeneinheit 066 Linkslauf <i>Conjunto cart. y platos 066 giro i.</i>	Cart. et plaque ass. 066 rot. g.	S24.10184	S24.40021	1
A	Cart. and plate ass'y 072 C.W. <i>Ins. cart. 072 oraria</i>	Pumpeneinheit 072 Rechtslauf <i>Conjunto cart. y platos 072 giro d.</i>	Cart. et plaque ass. 072 rot. d.	S24.40026	S24.40022	1
A	Cart. and plate ass'y 072 C.C.W. <i>Ins. cart. 072 antioraria</i>	Pumpeneinheit 072 Linkslauf <i>Conjunto cart. y platos 072 giro i.</i>	Cart. et plaque ass. 072 rot. g.	S24.40027	S24.40023	1
B	Seal kit (S1 - 0,7 bar) (T6E-T6EM) <i>Serie guarnizioni (S1 - 0,7 bar) (T6E-T6EM)</i>	Dichtringsatz (S1 - 0,7 bar) (T6E-T6EM) <i>Juego de juntas (S1 - 0,7 bar) (T6E-T6EM)</i>	Pochette de joint (S1 - 0,7 bar) (T6E-T6EM)	S24.10186	S24.10186	1
	Seal kit (S1 - 0,7 bar) (T6EP) <i>Serie guarnizioni (S1 - 0,7 bar) (T6EP)</i>	Dichtringsatz (S1 - 0,7 bar) (T6EP) <i>Juego de juntas (S1 - 0,7 bar) (T6EP)</i>	Pochette de joint (S1 - 0,7 bar) (T6EP)		S24.33397	1
	Seal kit (S4 - 7 bar) <i>Serie guarnizioni (S4 - 7 bar)</i>	Dichtringsatz (S4 - 7 bar) <i>Juego de juntas (S4 - 7 bar)</i>	Pochette de joint (S4 - 7 bar)	S24.10186.4	S24.10186.4	1
	Seal kit (S5 - 7 bar) <i>Serie guarnizioni (S5 - 7 bar)</i>	Dichtringsatz (S5 - 7 bar) <i>Juego de juntas (S5 - 7 bar)</i>	Pochette de joint (S5 - 7 bar)	S24.10186.5	S24.10186.5	1
C	Shaft and bearing ass'y (code 1) <i>Ins. albero (codice 1)</i>	Baugruppe (Welle u. Lager) (Typ 1) <i>Conjunto eje cojinete (codigo 1)</i>	Arbre et roulement ass. (code 1)	S14.28174	S14.28174	1
D	Shaft and bearing ass'y (code 2) <i>Ins. albero (codice 2)</i>	Baugruppe (Welle u. Lager) (Typ 2) <i>Conjunto eje cojinete (codigo 2)</i>	Arbre et roulement ass. (code 2)	S24.49212	S24.49212	1

Item Pos. Ref. Pos. Pos.	Description <i>Descrizione</i>	Benennung <i>Descripcion</i>	Description	Part N° Teil Nr. Code N° Cod. N° Referencia T6E	Part N° Teil Nr. Code N° Cod. N° Referencia T6EM - T6EP	Qty Stück Qté Q.tà Cant.
E	Shaft and bearing ass'y (code 3) (T6E-T6EM) <i>Ins. albero (codice 3) (T6E-T6EM)</i>	Baugruppe (Welle u. Lager) (Typ 3) (T6E-T6EM) <i>Conjunto eje cojinete (codigo 3) (T6E-T6EM)</i>	Arbre et roulement ass. (code 3) (T6E-T6EM)	S14.28173	S14.28173	1
	Shaft and bearing ass'y (code 3) (T6EP) <i>Ins. albero (codice 3) (T6EP)</i>	Baugruppe (Welle u. Lager) (Typ 3) (T6EP) <i>Conjunto eje cojinete (codigo 3) (T6EP)</i>	Arbre et roulement ass. (code 3) (T6EP)		S24.40001	1
F	Shaft and bearing ass'y (code 4) <i>Ins. albero (codice 4)</i>	Baugruppe (Welle u. Lager) (Typ 4) <i>Conjunto eje cojinete (codigo 4)</i>	Arbre et roulement ass. (code 4)		S24.00092	1
G	Shaft and bearing ass'y (code T) <i>Ins. albero (codice T)</i>	Baugruppe (Welle u. Lager) (Typ T) <i>Conjunto eje cojinete (codigo T)</i>	Arbre et roulement ass. (code T)		S24.33622	1
H	Port plate-rear and bush ass'y C.C.W. <i>Ins. piatto distributore post. antioraria</i>	Steuerplatte mit Buchse Linkslauf <i>Conj. plato dist. tras. con coj. fricción giro I</i>	Plaque ar. et bague ass. rot. gauche	S24.10176	S24.10176	1
J	Port plate-rear and bush ass'y C.W. <i>Ins. piatto distributore post. oraria</i>	Steuerplatte mit Buchse Rechtslauf <i>Conj. plato dist. tras. con coj. fricción giro D</i>	Plaque ar. et bague ass. rot. droite	S24.10175	S24.10175	1
Notes						

Model Code**Typenschlüssel****Designation - type****T6E INDUSTRIAL****Model number :****Typenbezeichnung :****Numéro du modèle :****T6E . - 066 - 1 R 00 - A 1 ..****Series** _____**Baureihe** _____**Série** _____

One letter can be added to specify special parts in series _____

Optionen _____

Une lettre peut être ajoutée pour spécifier les pièces spéciales dans la série. _____

Cam ring _____**geom. Fördervolumen (Flügelzellenpumpe)** _____**Came** _____(delivery at 0 bar - 1500 rpm)
042 = 198,5 l/min
045 = 213,6 l/min
050 = 237,7 l/min
052 = 247,2 l/min(Förderstrom bei 0 bar - 1500 U/min)
062 = 295,0 l/min
066 = 319,9 l/min
072 = 340,6 l/min

(débit 0 bar - 1500 tr/min)

Type of shaft _____**Art der Welle** _____**Type d'arbre** _____1 = keyed (SAE CC)
2 = keyed (non SAE)
3 = splined (SAE C)
4 = splined (SAE CC)1 = Paßfederwelle (SAE CC)
2 = Paßfederwelle (nicht SAE)
3 = Vielkeilwelle (SAE C)
4 = Vielkeilwelle (SAE CC)1 = à clavette (SAE CC)
2 = à clavette (non SAE)
3 = à cannelures (SAE C)
4 = à cannelures (SAE CC)**Direction of rotation** _____**Drehrichtung** _____**Sens de rotation** _____R = Clockwise
L = Counter-clockwiseR = Rechtslauf
L = LinkslaufR = à droite
L = à gauche**Porting combination** _____**Lage der Anschlüsse** _____**Combinaison des orifices** _____

00 = standard

00 = standard

00 = standard

Design letter _____**Ausführungsbuchstabe** _____**Conception** _____**Seal class** _____**Dichtungsklasse** _____**Classe de joint** _____1 = S1 - BUNA N
4 = S4 - EPDM
5 = S5 - VITON1 = S1 - BUNA N
4 = S4 - EPDM
5 = S5 - VITON1 = S1 - BUNA N
4 = S4 - EPDM
5 = S5 - VITON**Modifications** _____**Modifikationen** _____**Modifications** _____

Designazione

Clave de designación

T6E INDUSTRIAL

Sigla :

Referencia modelo :

T6E . - 066 - 1 R 00 - A 1 ..

Serie _____

Serie _____

Una lettera può essere aggiunta per specificare parti speciali nella serie

Una letra puede ser añadida para especificar piezas especiales en la serie

Tipo di cartuccia _____

(Portata a 0 bar e 1500 g/min)
042 = 198,5 l/min
045 = 213,6 l/min
050 = 237,7 l/min
052 = 247,2 l/min

Aro volumetrico _____

(Caudal 0 bar - 1500 rpm)
062 = 295,0 l/min
066 = 319,9 l/min
072 = 340,6 l/min

Tipo di albero _____

1 = a chiavetta (SAE CC)
2 = a chiavetta
3 = scanalato (SAE C)
4 = scanalato (SAE CC)

Tipo de eje _____

1 = chaveteado (SAE CC)
2 = chaveteado (no SAE)
3 = estriado (SAE C)
4 = estriado (SAE CC)

Senso di rotazione _____

R =orario
L = Antiorario

Sentido de giro _____

R = Derecha
L = Izquierda

Orientamento delle bocche _____

00 = standard

Posición de bocas _____

00 = estándar

Disegno _____

Letra de diseño _____

Tipo di guarnizioni _____

1 = S1 - BUNA N
4 = S4 - EPDM
5 = S5 - VITON

Clase de juntas _____

1 = S1 - BUNA N
4 = S4 - EPDM
5 = S5 - VITON

Modifiche _____

Modificaciones _____

Model Code

Typenschlüssel

Designation - type

T6E MOBILE

Model number :

Typenbezeichnung :

Numéro du modèle :

T6E* . - 066 - 1 R 00 - B 1 ..

Series M = Mobile 1 shaft seal
Series P = Mobile 2 shaft seals

Version M = Mobil, 1 Wellendichtung
Version P = Mobil, 2 Wellendichtung

Série M = Mobile 1 joint d'arbre
Série P = Mobile 2 joints d'arbre

One letter can be added to specify special parts in series

Optionen

Une lettre peut être ajoutée pour spécifier les pièces spéciales dans la série.

Cam ring
(delivery at 0 bar - 1500 rpm)
042 = 198,5 l/min
045 = 213,6 l/min
050 = 237,7 l/min
052 = 247,2 l/min

geom. Fördervolumen (Flügelzellenpumpe)
(Förderstrom bei 0 bar - 1500 U/min)
062 = 295,0 l/min
066 = 319,9 l/min
072 = 340,6 l/min

Came
(débit 0 bar - 1500 tr/min)

Type of shaft
M version
1 = keyed (SAE CC)
2 = keyed (non SAE)
3 = splined (SAE C)
4 = splined (SAE CC)
T = splined (SAE J718c)

Art der Welle
Version M
1 = Paßfederwelle (SAE CC)
2 = Paßfederwelle (nicht SAE)
3 = Vielkeilwelle (SAE C)
4 = Vielkeilwelle (SAE CC)
T = Vielkeilwelle (SAE J718c)

Type d'arbre
Version M
1 = à clavette (SAE CC)
2 = à clavette (non SAE)
3 = à cannelures (SAE C)
4 = à cannelures (SAE CC)
T = à cannelures (SAE J718c)

P version
3 = splined (non SAE)

Version P
3 = Vielkeilwelle (nicht SAE)

Version P
3 = à cannelures (non SAE)

Direction of rotation
R = Clockwise
L = Counter-clockwise

Drehrichtung
R = Rechtslauf
L = Linkslauf

Sens de rotation
R = à droite
L = à gauche

Porting combination
00 = standard

Lage der Anschlüsse
00 = standard

Combinaison des orifices
00 = standard

Design letter

Ausführungsbuchstabe

Conception

Seal class
1 = S1 - BUNA N
4 = S4 - EPDM
5 = S5 - VITON

Dichtungsklasse
1 = S1 - BUNA N
4 = S4 - EPDM
5 = S5 - VITON

Classe de joint
1 = S1 - BUNA N
4 = S4 - EPDM
5 = S5 - VITON

Modifications

Modifikationen

Modifications

Designazione

Clave de designación

T6E MOBILE

Sigla :

Serie M = Mobile 1 guarnizione albero
Serie P = Mobile 2 guarnizioni albero

Una lettera può essere aggiunta per specificare parti speciali nella serie

Tipo di cartuccia

(Portata a o bar e 1500 g/min)
042 = 198,5 l/min
045 = 213,6 l/min
050 = 237,7 l/min
052 = 247,2 l/min

Tipo di albero

Versione M

1 = a chiavetta (SAE CC)
2 = a chiavetta
3 = scanalato (SAE C)
4 = scanalato (SAE CC)
T = scanalato (SAE J718c)

Versione P

3 = scanalato

Senso di rotazione

R =orario
L = Antiorario

Orientamento delle bocche

00 = standard

Diseño

Tipo di guarnizioni

1 = S1 - BUNA N
4 = S4 - EPDM
5 = S5 - VITON

Modifiche

Referencia modelo :

Serie M = Movil 1 reten eje
Serie P = Movil 2 retenes eje

Una letra puede ser añadida para especificar piezas especiales en la serie

Aro volumetrico

(Caudal 0 bar - 1500 rpm)
062 = 295,0 l/min
066 = 319,9 l/min
072 = 340,6 l/min

Tipo de eje

Version M

1 = chaveteado (SAE CC)
2 = chaveteado (no SAE)
3 = estriado (SAE C)
4 = estriado (SAE CC)
T = estriado (SAE J718c)

Version P

3 = estriado (no SAE)

Sentido de giro

R = Derecha
L = Izquierda

Posición de bocas

00 = estándar

Letra de diseño

Clase de juntas

1 = S1 - BUNA N
4 = S4 - EPDM
5 = S5 - VITON

Modificaciones

T6E* . - 066 - 1 R 00 - B 1 ..

