

**DENISON HYDRAULICS**  
*Goldcup series 6C, 7A & 8A*  
axial piston pump  
variable displacement with auxiliary package  
service information



S1-AM007-B replaces S1-AM007-A



Internet: <http://www.denisonhydraulics.com> E-mail: [denison@denisonhydraulics.com](mailto:denison@denisonhydraulics.com)

# CONTENTS

	<b>PAGE</b>
typical characteristics-----	3
fluid connections-----	3
installation-----	4
maintenance-----	5
start up procedures-----	5
comparison of solid contamination classification systems-----	6
troubleshooting-----	6
assembly tool drawings-----	8
disassembly-----	10
rework of wear parts-----	11
assembly-----	12
drive shaft & bearing-----	12
barrel & auxiliary drive shaft-----	12
cam/cradle assemblies-----	13
piston/shoe/retainer assemblies-----	13
rocker cam, pistons & retainer-----	14
mtg. flg./cradle/barrel/aux. shaft assy-----	16
housing assembly-----	16
hsg./end cap/cam/barrel assembly-----	17
port block assembly-----	17
mounting port block to housing assembly-----	18
gerotor & barrel holddown-----	19
valve block assembly (before 7-93)-----	22
valve block assembly (after 7-93)-----	24
valve block assembly for special mounting of servovalve (before 7-93)-----	28
valve block assembly for special mounting of servovalve (after 7-93)-----	30
shaft & seal installation-----	34
counterbalance servo stem installation-----	35
control cover installation-----	35
instructions for replenishing isolation plug-----	36
gage locations-----	37
P*P,P*D test procedure -----	38
P*V test procedure -----	40
basic pump installation drawing-----	42
technical data conversions-----	44
pump key sheet-----	45
seal kits (see key sheet pg. 45 for information)	
pump complete less controls	S23-00134
valve block	S23-00135
hi-iq valve block	S23-04226
shaft seal kit, SAE 127-2 mtg.	S23-44302
shaft seal, SAE 127-2 mtg.	623-00006
shaft seal, SAE 152-4 mtg.	623-00016
controls	S23-02303

**NOTE:** New revisions are shown underlined. Pages are marked Revised where changes have been made.

# INSTALLATION

## TYPICAL CHARACTERISTICS

Specification	Term	Goldcup 6	Goldcup 7	Goldcup 8
• displacement at max. angle	in <sup>3</sup> /rev. cm <sup>3</sup> /rev.	6.00 98,3	7.25 118,8	8.00 131
• pressure continuous	psi bar	5000 345	5000 345	<u>3600</u> <u>250</u>
• pressure intermittent	psi bar	6000 414	6000 414	<u>4500</u> <u>310</u>
• speed, max. continuous	RPM	3000	3000	1800
• flow, ports A or B @ 1800 RPM (theoretical)	GPM l/min.	46.8 177	56.5 213,8	62.3 235,8
• flow, repl. pump @ 1800 RPM (theoretical)	GPM l/min.	8.33 31,6	8.33 31,6	8.33 31,6
• servo pressure-closed circuit	psi bar	335-535 23-37	335-535 23-37	335-535 23-37
• servo pressure -open circuit	psi bar	150-525 10-35	150-525 10-35	150-525 10-35
• <u>mounting-flange</u>	<u>SAE</u>	<u>127-2, 152-4</u> <u>(C, D)</u>	<u>127-2, 152-4</u> <u>(C, D)</u>	<u>127-2, 152-4</u> <u>(C, D)</u>
• <u>shaft-keyed</u>	<u>SAE</u>	<u>32-1, 44-1</u> <u>(C, D)</u>	<u>32-1, 44-1</u> <u>(C, D)</u>	<u>32-1, 44-1</u> <u>(C, D)</u>
• <u>shaft-splined</u>	<u>SAE</u>	<u>32-4, 44-4</u> <u>(C, D)</u>	<u>32-4, 44-4</u> <u>(C, D)</u>	<u>32-4, 44-4</u> <u>(C, D)</u>
• weight w/spg. ctd. rotary servo	lbs. kg.	175 79	175 79	175 79

## FLUID CONNECTIONS

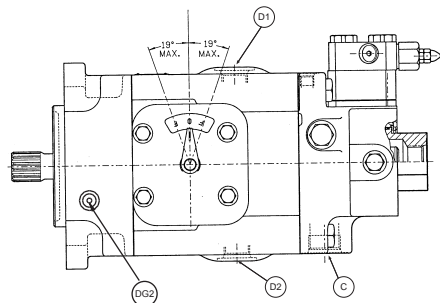
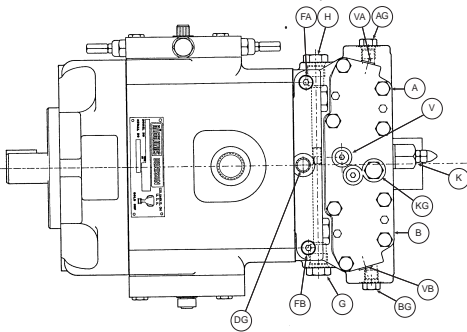

• port A -closed circuit (system) SAE code 62 split flange	in. mm	1-1/2 38,1	1-1/2 38,1	1-1/2 38,1
• port A -open circuit (inlet) SAE code 61 split flange	in. mm	2 50,8	2 50,8	2 50,8
• port B (system) SAE code 62 split flange	in. mm	1-1/2 38,1	1-1/2 38,1	1-1/2 38,1
• port AG,BG (A&B system gage) straight thread O-ring seal	SAE	-6	-6	6
• port C (aux. pump inlet) straight thread O-ring seal	SAE	-16	-16	-16
• port D1,D2 (case drains) straight thread O-ring seal	SAE	-12	-12	-12
• port DG (case gage) straight thread O-ring seal	SAE	-6	-6	-6
• port FA,FB (control pressures) dryseal	NPTF	1/4"	1/4"	1/4"
• port G (aux. pump outlet) port H (aux. flow return) straight thread O-ring seal	SAE	-8	-8	-8
• port K (aux. repl inlet) straight thread O-ring seal	SAE	-16	-16	-16
• port KG (repl. gage) straight thread O-ring seal	SAE	-6	-6	-6
• port V (common vent) port VA,VB (A&B side vents) straight thread O-ring seal	SAE	-4	-4	-4
• <u>port DG2 (case)</u> <u>straight thread O-ring seal</u>	<u>SAE</u>	<u>-4</u>	<u>-4</u>	<u>-4</u>

## INTRODUCTION

The **DENISON HYDRAULICS** Goldcup 6, Goldcup 7 and Goldcup 8 axial piston pumps feature advance design concepts which are time proven and provide for advance pumping and control concepts. The instructions contained in this manual cover complete disassembly and re-assembly of the unit. Before proceeding with the disassembly or re-assembly of any unit, this manual should be studied in order to become familiar with proper order and parts nomenclature.

## DESCRIPTION

The use of a rocker cam to control the pump displacement provides a small package size, reduces wear, and speeds control response. The control vane actuator eliminates linkage and backlash inherent in typical stroking cylinder designs.

Standard controls for the Goldcup units are rotary servo and compensator over-ride. Additional optional controls are also available.

## MOUNTING

This pump is designed to operate in any position. The mounting hub and two bolt mounting flange are in full conformance with SAE standard. The pump shaft must be in alignment with the shaft of the driving load and should be checked with a dial indicator. The mounting pad or adapter into which the fluid pump pilots must be concentric with the pump shaft to prevent bearing failure. This concentricity is particularly important if the shaft is rigidly connected to the driving load without a flexible coupling.

## SHAFT INFORMATION

**Splined:** The shafts will accept a maximum misalignment of .006" TIR, 0,15 mm. Angular misalignment at the male and female spline axes must be less than  $\pm .002$ " per inch radius, 0,002 mm per mm radius. The coupling interface must be lubricated. **DENISON HYDRAULICS** recommends lithium- molybdenum disulfide or similar grease. The female coupling should be hardened to 27-45 Rc and must conform to SAE-J498B (1971) class 1 flat root side fit.

**Keyed:** High strength heat treated keys must be used. Replacement keys must be hardened to 27-34 Rc. The key corners must be chamfered .03"- .04", 0,75-1 mm at 45° to clear radii that exist in the keyway.

## SIDE LOAD

C- flange pumps will accept a side load of 170 lb., 77 kg, and D- flange pumps will accept a side load of 215 lb, 97 kg, at the center of the spline or key, with a B10 life of 10000 hours at 1800 RPM.

## PIPING

Connect inlet and outlet lines to the port block of the pump.

The maximum case pressure is 75 PSI, 5,7 bar continuous, 125 PSI, 8,6 bar intermittent. Case pressures must never exceed inlet pressure by more than 25 PSI, 1,7 bar. When connecting case drain line make certain that drain plumbing passes above highest point of the pump before passing to the reservoir. If not, install a 5 PSI, 0,3 bar case pressure check valve to be certain the case is filled with oil at all times.

The case leakage line must be of sufficient size to prevent back pressure in excess of 75 PSI, 5,7 bar and returned to the reservoir below the surface of the oil as far from the supply suction as possible. All fluid lines, whether pipe, tubing, or hose must be adequate size and strength to assure free flow through the pump. An undersize inlet line will prevent the pump from operating at full rated speed. An undersize outlet line will create back pressure and cause heat generation. Flexible hose lines are recommended. If rigid piping is used, the workmanship must be accurate to eliminate strain on the pump port block or to the fluid connections. Sharp bends in the lines must be eliminated wherever possible. All system piping must be cleaned with solvent or equivalent before installing pump. Make sure the entire hydraulic system is free of dirt, lint, scale, or other foreign material.

**CAUTION:** Do not use galvanized pipe. Galvanized coating can flake off with continued use.

## SERVICE INFORMATION

These hydraulic products are designed to give long dependable service when properly applied and their systems properly maintained. These general instructions apply to typical systems. Specific instructions for particular equipment can be developed from them.

## RECOMMENDED FLUIDS

The fluid recommended for use in these pumps and motors has a petroleum base and contains agents which provide oxidation inhibition and anti-rust, anti-foam and de-aerating properties as described in **DENISON HYDRAULICS** standard HF-1. Where anti-wear additive fluids are specified, see **DENISON HYDRAULICS** standard HF-0.

## VISCOSITY

Max. at cold start - 7500 SUS, 1600 Cst  
 (at low pressure, low flow, and if possible, low speed)  
 Max. at full power - 750 SUS, 160 Cst  
 Optimum for max. life - 140 SUS, 30 Cst  
 Minimum at full power - 60 SUS, 10 Cst

## VISCOSITY INDEX

90 V.I. minimum. Higher values extend the range of operating temperature but may reduce the service life of the fluid.

## TEMPERATURE

Determined by the viscosity characteristics of the fluid used. Because high temperatures degrade seals, reduce the service life of the fluid and create hazards, fluid temperatures should not exceed 180° F, 82° C at the case drain.

## ALTERNATE FLUIDS

Some applications require fire-resistant fluids. They will give good service if the system is originally designed for their use. Permissible fire resistant fluids include:

Type	DENISON HYDRAULICS Standard
Water-in-oil invert emulsions	HF-3
Water glycol solutions	HF-4
Phosphate esters	HF-5

Consult **DENISON HYDRAULICS** for design requirements and warranty limitations for service with this class of fluids.

See **DENISON HYDRAULICS** bulletin SPO-AM305 for more information.

## FILLING CASE

It is essential to make certain that the case (pump housing) is as full of fluid as possible and remains full during operation and at rest.

Always fill to the highest available point. Remove a plug or screw and allow the oil to escape through this point.

Recommended fill points:

Mounting orientation vertical, shaft up. D1 or D2 (drain) port in housing Vent DG2 port in mounting flange (new units) or one of the upper screws which attach the control. See installation drawing.

Vertical, shaft down <sup>1)</sup> or horizontal drain ports to the side. D1 or D2 (drain port in housing. <sup>1)</sup> Vent DG (case gage) port in port block.

## MAINTENANCE

This pump is self-lubricating and preventative maintenance is limited to keeping system fluid clean by changing filters frequently. Keep all fittings and screws tight. Do not operate at pressures and speeds in excess of the recommended limit. If the pump does not operate properly, check the troubleshooting chart before attempting to overhaul the unit. Overhauling is relatively simple and may be accomplished by referring to the disassembly, rework limits of wear parts, and assembly procedures.

## FLUID CLEANLINESS

Fluid must be cleaned before and continuously during operation, by filters that maintain a cleanliness level of NAS 1638 class 8 (class 9 for 15 micron and smaller). This approximately corresponds to ISO 17/14. This fluid level cleanliness can usually be accomplished by the effective use of 10 micron filters. Better cleanliness levels will significantly extend the life of the components. As contaminant generation may vary with each application, each must be analyzed to determine proper filtration to maintain the required cleanliness level.

## START UP PROCEDURES FOR NEW INSTALLATION

- Read and understand the instruction manual. Identify components and their function.
- Visually inspect components and lines for possible damage.
- Check reservoir for cleanliness and drain and clean as required.
- Check fluid level and fill as required with filtered fluid at least as clean as that recommended. Fill pump case with clean oil prior to starting.
- Check alignment of drive.
- Check oil cooler and activate it, If included in circuit.
- Reduce pressure settings of relief valve. Make sure accurate pressure readings can be made at appropriate places.
- If solenoids are included in system, check for actuation.
- Start pump drive. Make sure pump and motor fill properly.
- Bleed system of air. Re-check fluid level.
- Cycle unloaded machine at low pressure and observe actuation (at low speed, if possible).
- Increase pressure settings gradually in steps. Check for leaks in all lines, especially pump and motor inlet lines.
- Make correct pressure adjustments.
- Gradually increase speed. Be alert for trouble as indicated by changes in sounds, system shocks and air in fluid.
- Equipment is operational.

COMPARISON OF SOLID CONTAMINATION CLASSIFICATION SYSTEMS

NATIONAL AERONAUTICS STANDARD (NAS) 1638

		class													
		00	0	1	2	3	4	5	6	7	8	9	10	11	12
particle size range	5-15µm	125	250	500	1000	2000	4000	8000	16000	32000	64000	128000	256000	512000	1024000
	15-25µm	22	44	89	178	356	712	1425	2850	5700	11400	22800	45600	91200	182400
	25-50µm	4	8	16	32	63	126	253	506	1012	2025	4050	8100	16200	32400
	50-100µm	1	2	3	6	11	22	45	90	180	360	720	1440	2880	5760
	>100µm	0	0	1	1	2	4	8	16	32	64	128	256	512	1024
maximum particles	5µm	152	304	609	1217	2432	4864	9731	19462	38924	77849	155698	311396	622792	1245584
	15µm	27	54	109	217	432	864	1731	3462	6924	13849	27698	55396	110792	221584

ISO:DIS 4406; SAE J1165

		iso solid contaminant code														
		8/5	9/6	10/7	11/8	12/9	13/10	14/11	15/12	16/13	17/14	18/15	19/16	20/17	21/18	22/19
maximum	5µm	250	500	1000	2000	4000	8000	16000	32000	64000	130000	250000	500000	1000000	2000000	4000000
particles	15µm	32	64	130	250	500	1000	2000	4000	8000	16000	32000	64000	130000	250000	500000

NOTES: All measurements are for a 100 ml sample size.

TROUBLESHOOTING

Component problems and circuit problems are often interrelated. An improper circuit may operate with apparent success but will cause failure of a particular component within it. The component failure is the effect, not the cause of the problem.

This general guide is offered to help in locating and eliminating the cause of problems by studying their effects.

effect of trouble	possible cause	fault which needs remedy
noisy pump	air in fluid	leak in suction line leak at shaft seal low fluid level turbulent fluid return lines above fluid level gas leak from accumulator excessive pressure drop in the inlet line from a pressurized reservoir suction line strainer acting as air trap
	cavitation in pump or motor rotating group	fluid too cold fluid too viscous fluid too heavy shaft speed too high suction line too small suction line collapsed suction strainer too small suction strainer too dirty operating altitude too high boost or replenishment pressure too low replenishment flow too small for dynamic conditions
	misaligned shaft	faulty installation distortion in mounting axial interference faulty coupling excessive overhung loads
	mechanical fault in pump	piston and shoe looseness or failure bearing failure incorrect port plate selection or index eroded or worn parts in the displacement control
erosion on barrel ports and port plate	air in fluid	see above
	cavitation	see above
high wear in pump and motor	excessive loads	reduce pressure settings reduce speeds
	contaminant particles in fluid	improper filter maintenance filters too coarse introduction of dirty fluid to system reservoir openings improper reservoir breather improper line replacement

## TROUBLESHOOTING

### TROUBLESHOOTING

(continued)

effect of trouble	possible cause	fault which needs remedy
high wear in pump and motor (continued)	Improper fluid	fluid too thin or thick for operating temperature range breakdown of fluid with time/temperature/shearing effects incorrect additives in new fluid destruction of additive effectiveness with chemical aging
	improper repair	incorrect parts incorrect procedures, dimensions, finishes
	unwanted water in fluid	condensation faulty breather/strainer heat exchanger leakage faulty clean-up practice water in makeup fluid
pressure shocks	cogging load	mechanical considerations
	worn relief valve	needed repairs
	worn compensator	needed repairs
	slow response in check valves	replace or relocate
	servo pressure too low to maintain firm control	increase pressure and check pressure drop through servo filter
	excessive decompression energy rates	improve decompression control
	excessive line capacitance (line volume, line stretch, accumulator effects)	reduce line size or lengths eliminate hose
	barrel blow-off	re-check pump hold-down, rotating group, drain pressure
heating of fluid	excessive pump or motor leakage	recheck case drain flow and repair as required fluid too thin improper assembly, port timing
	relief valve	set too low (compared to load or to compensator) instability caused by back pressure, worn parts
	compensator	set too high (compared to relief) worn parts
	pump too large for fluid needs	select smaller pump displacement
	heat exchanger	water turned off or too little flow water too hot fan clogged or restricted efficiency reduced by mud or scale deposits intermittent hydraulic fluid flow
	reservoir	too little fluid entrained air in fluid improper baffles insulating air blanket that prevents heat rejection heat pickup from adjacent equipment

T-1

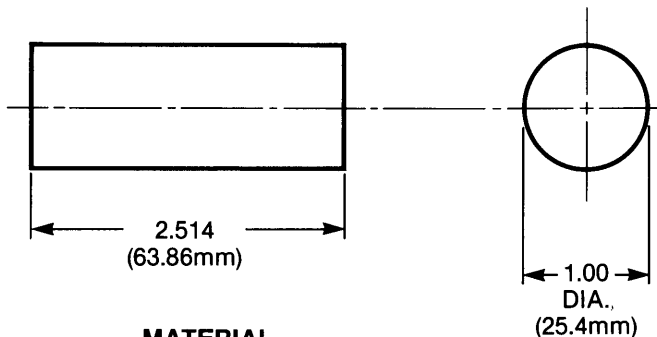

MATERIAL:

**C R S 1" DIA. x 2<sup>5</sup>/<sub>8</sub>"**  
 (25.4mm) (66.68mm)

T-2

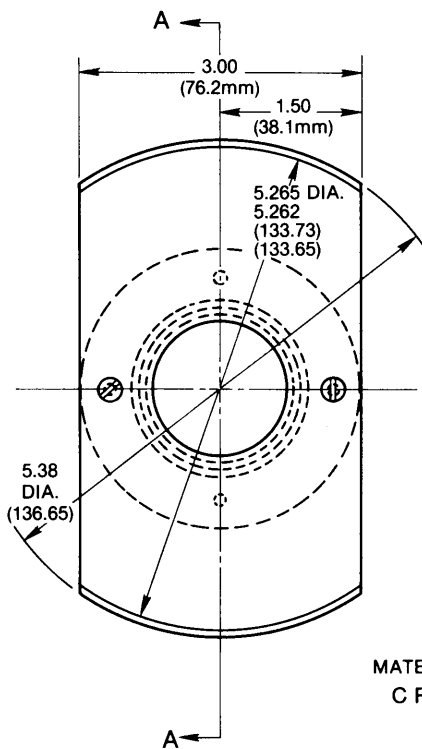

MATERIAL  
C R S

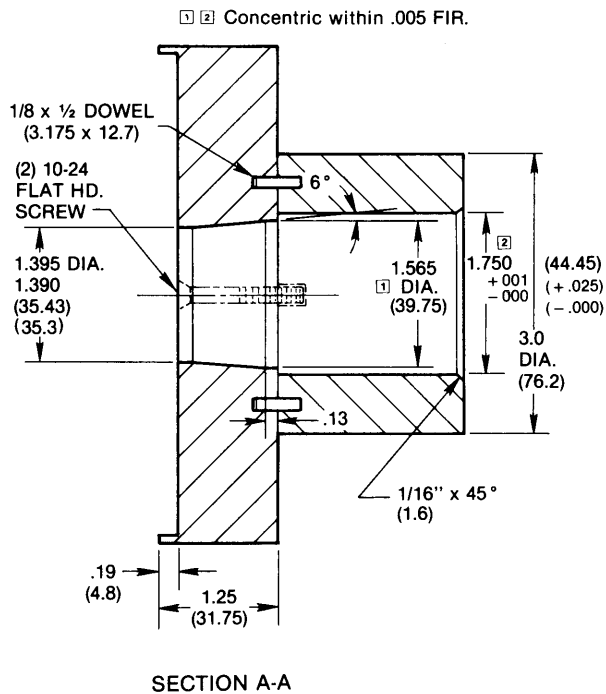

Note: Dimensions in ( ) are mm.



T-3

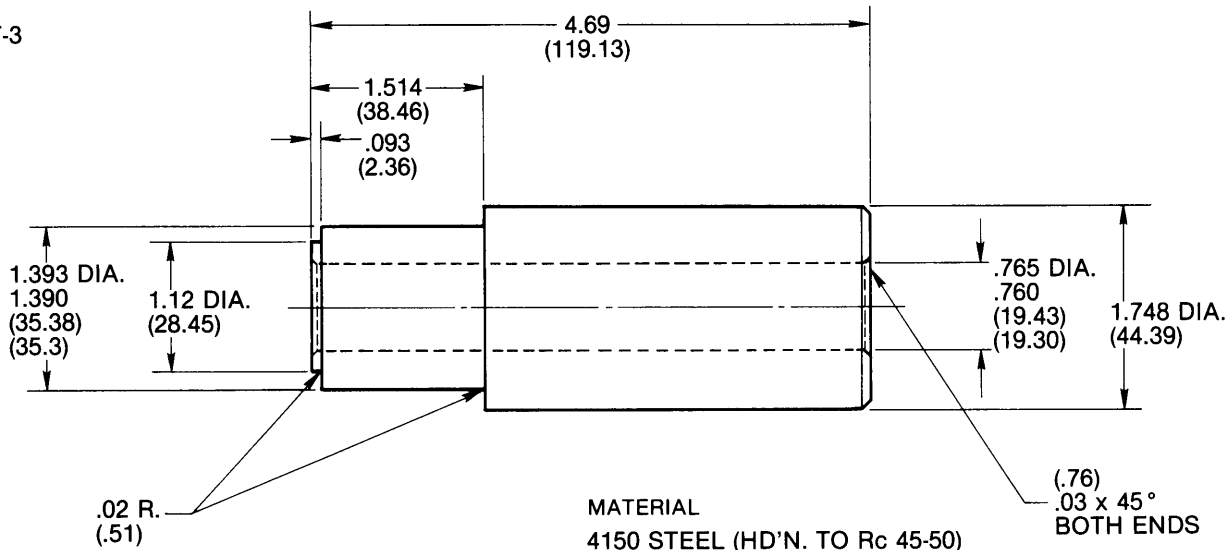

T-4

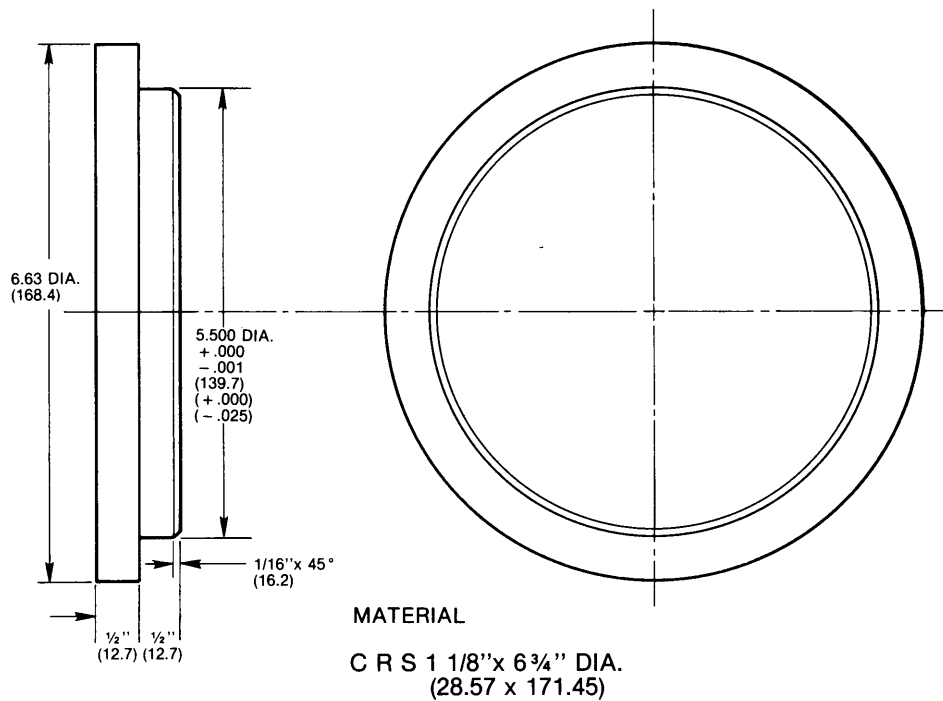

T-5

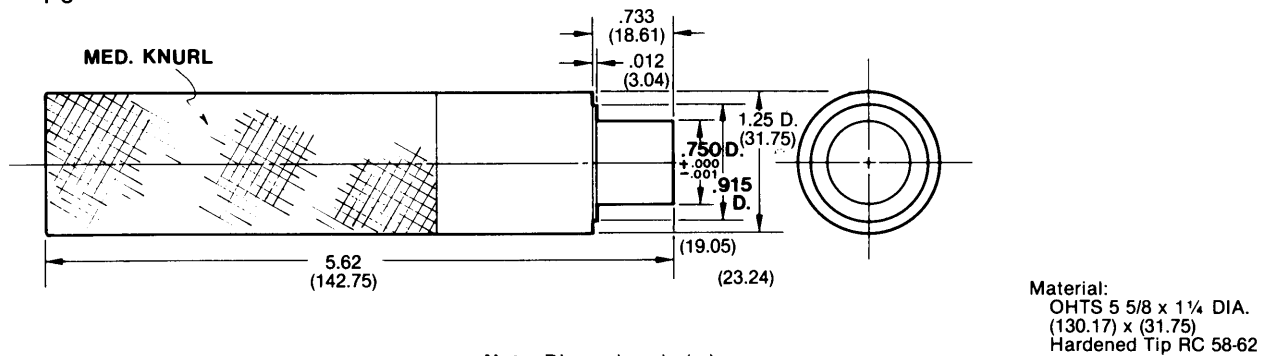

Note: Dimensions in ( ) are mm.

**INTRODUCTION**

The instructions contained in this section cover a complete teardown of the subject pump. Disassemble only as far as necessary to replace or repair any worn parts.

**DISASSEMBLY**

Position pump unit so that valve block assembly is on top. A bench or similar suitable surface capable of supporting unit should be used. Disassembly area should be clean.

**VALVE BLOCK**

**See figure 14.** Remove the eight hex head cap screws (17) and lift the entire block assembly from the port block.

**See figure 10.** Remove the four screws (39) to separate the cover (21) from the block (11). Do not remove the check valves (19). (valve blocks before 7-93) (For other version valve blocks, refer to figures 11, 12 or 13.)

Remove the plugs (43), (36) and pin (40). Refer to servo strainer assembly (34). Remove the SHCS retaining the strainer, remove the strainer and strainer support

Remove housing (29) and O-ring (28). Remove items (30), (31), (32), and (33) as a unit. Insert a small brass rod through the hole in the housing and tap out piston (27) and O-ring (26).

Remove spring (25) and cone (24). Remove seat (23) and O-ring (22).  
NOTE: Seat is made for hex wrenching. Use 1/2" 6 point socket with 1/4" drive.

Remove O-ring (37) and replenishing relief valve (41). Inspect orifices (12) visually to insure they are open. Do not remove unless damage or clogging is apparent.

Remove springs (16), (17), and (18). Remove retainer (15) and poppets (13) and (14).

Remove the four screws (4) from the plate (6) and (11). Remove gasket (7)

Remove seats (8) and (9). Do not remove spring pins (5) and (10) unless replacements are needed.

**CONTROLS**

**See figure 14.** Remove the four screws (14) from the side cover (16) and remove the input shear seal control assembly.

Remove the four screws (14) from the side cover (15) and remove the counter balance shear seal control assembly.

Remove the two screws (12) and remove the servo stem (9) and balance plate (10).

**BARREL HOLDDOWN AND GEROTOR ASSEMBLY**

**See figure 9.** Remove snap ring (17), end cover (15) and O-ring (16).

Remove retainer ring (18), pin (14), holddown nut (13), thrust washers (10), bearing (11) and seal ring (12).

Remove pressure plate (9), gerotor side plate (5a), O-rings (7) and (8), needle bearing (5b).

Remove gerotor assembly (3), dowel pin (4), key (2), and side plate (1).

**PORT BLOCK**

**See figure 8.** Remove four screws (1) that secure the port block (2) to the housing (6). Use caution when removing screws on valve block side to prevent marring valve block face.

Remove port block (2) and gasket (5). Remove port plate (4) and port plate pins (3). Note: port plate will in some instances adhere to port block upon disassembly.

**See figure 7.** Remove the check valve assemblies (7) from the port block.

Remove the needle bearing (2) from the port block.

Remove two screws (5), lockwashers (6), check rings (3), and clamps (4). (Open circuit pumps use solid rings, which need not be removed).

Remove face plate (2, fig. 6) from face of barrel assembly.

Remove the barrel assembly (1, fig. 4) by grasping the auxiliary shaft and lifting the complete assembly out of the housing.

**BARREL AND AUXILIARY SHAFT****DRIVE SHAFT**

**See figure 14.** Remove the four screws (8) and gaskets (7). Remove seal retainer (6), and the stationary part of the shaft seal (4). refer to view of item 4.

**DRIVE SHAFT**

*(continued)*

Carefully remove the carbon ring and the remainder of the shaft seal from the shaft.

**Caution:** Do not scratch seal surface of shaft when removing seal.

Remove snap ring (3) and the shaft and bearing assembly (1). Remove shim (2) (SAE-C only).

**HOUSING**

After shaft assembly has been removed, position the unit on end with the mounting flange turned down.

Push the ends of the small tube lines away from the housing.

Lift the housing from the mounting flange, remove the gasket and dowel pins from the mounting flange.

Do not remove the spring pins and the bearing from the housing unless the bearing is damaged and must be replaced.

**ROCKER CAM AND CONTROL STROKING ASSEMBLY**

**See figure 4.** Remove the complete assembly from the mounting cap and position on a clean flat surface with the two tubes (2) in a horizontal position and located at the top. Mark the cam (24) and cradle (20) as indicated in figure 3. These marks will assure re-assembly in the same position.

Carefully remove the small tube lines (3) and (4) from the cradle. **Caution:** do not bend these lines

**See figure 3.** Position the assembly in an upright position on the flat surface of the cradle (20). Remove the retaining ring (1) and thrust washer (2). Remove the piston and shoe assembly (4) and the creep plate (5) from the cam (24). Carefully remove the two set screws (6a) and two screws (6) that secure the servo plate to the cam (24) and remove the servo input parts (7, 8 and 9).

Remove the four screws (10) and eight screws (11) and (12) from the control covers (15R) and (15L). Remove the four dowel pins (16) and remove the two chambers (17). Remove the two special seals (18) and the four steel balls (19). Remove the two vane seal cartridge assemblies (23) and the four holddown vanes (22) from the rocker cam (24).

**Note:** Some units may have thin shims under the holddown vanes. Open circuit pumps have springs (21) under the holddown vanes.

Remove the rocker cam (24) from the cradle (20). **Caution:** Do not remove the plugs from the rocker cam.

**REWORK LIMITS OF WEAR PARTS**

<b>6, 7.25 and 8.0 in<sup>3</sup></b>	<b>max. rework from original</b>	<b>min. dimension after rework</b>
port plate face	.010", 0,254 mm	.295", 7,49 mm
shoe retainer face	.005", 0,127 mm	.307", 7,8 mm
piston shoe face (pocket)	.006", 0,152 mm	.008", 0,2 mm
creep plate face	.005", 0,127 mm	.286", 7.13 mm
face plate	none	replace

**IMPORTANT:**

The port plate finish must be 25 microinches, 635 μm both faces, flat within .00006", 0,0015 mm and parallel within .001", 0,0254 mm T.I.R.

The creep plate wear face finish must be 10 microinches, 254 μm, flat within .0002", 0,0581 mm and parallel to the backside within .0005", 0,0127 mm T.I.R.

The shoe retainer wear face finish must be 32 microinches 813 μm and flat within .0015", 0,0381 mm. (Must not be convex).

The piston shoes wear face finish must be 5 microinches, 127 μm and must be lapped in a set with the retainer plate, all shoe sole thicknesses to be within .001", 0,0254 mm after lapping. The maximum permissible shoe and piston axial looseness is .010", 0,254 mm

The special retaining ring service kit (S23-12461) may be required to control shoe hold-down clearance.

**CLEANING AND INSPECTION**

All parts must be inspected and be free of material defects, dirt, scratches or any foreign material.

All parts must be cleaned with a suitable cleaning solvent and all holes and passages blown out with dry, clean, compressed air.

After cleaning and inspection, all parts must be covered with a light film of oil and protected from dirt and moisture. Excessive handling of internal parts should be avoided prior to assembly.

During assembly, lapped and ground surfaces must be lubricated with clean oil and protected from nicks or surface damage.

**DRIVE SHAFT AND BEARING**

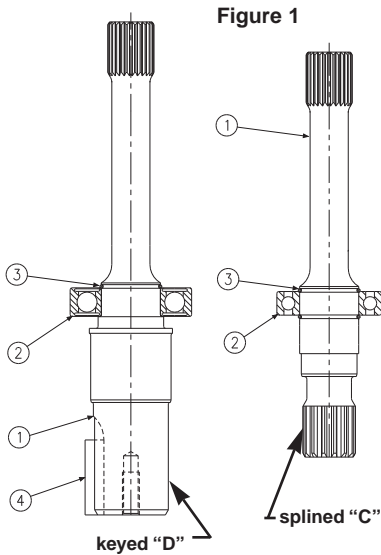

Figure 1

See Figure 1. Pass one retaining ring (3) over the internal end of drive shaft (12) and install in the groove nearest the shaft seal surface. Caution: Do not pass the ring over the seal surface. ("SAE-C" shafts only)

Press the bearing (2) over the internal splined end of the shaft and seat against the ring. Support only the inner race of the bearing and press on the coupling end of the shaft. Caution: Do not use excessive force and distort or damage the retaining ring!

Install the retaining ring (3) in the retaining ring groove. Be sure that ring(s) is/are fully seated.

**PARTS LIST FOR FIGURE 1**

item	description	part no.	quantity			
			#2	#3	#4	#5
1	#2 (keyed "C" shaft)	033-70579	1	-	-	-
	#3 (splined "C" shaft)	033-70567	-	1	-	-
	#4 (keyed "D" shaft)	033-92283	-	-	1	-
	#5 (splined "D" shaft)	033-92282	-	-	-	1
2	shaft bearing ("C")	230-82140	1	1	-	-
	shaft bearing ("D")	230-00207	-	-	1	1
3	retaining ring	033-70817	2	2	1	1
4	square key 5/16 x 1-1/4	033-71348	1	-	1	-

**DRIVE SHAFT ASSEMBLIES**

#2 S13-41806, SAE 32-1 (KEYED "C")

#4 S23-15832, SAE 44-1 (KEYED "D")

#3 S13-41805, SAE 32-4 (SPLINED "C")

#5, S23-15831, SAE 44-4 (SPLINED "D")

**BARREL AND AUXILIARY DRIVE SHAFT**

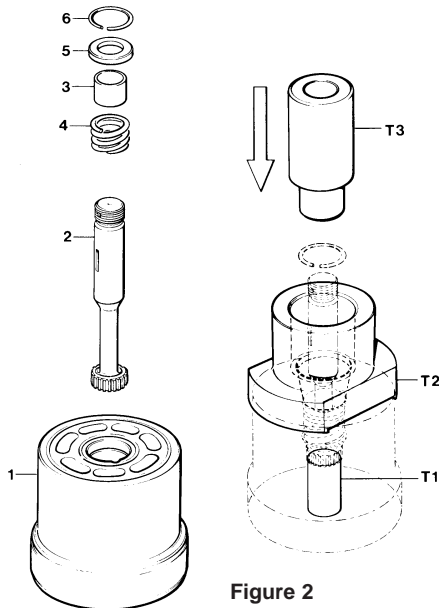

Figure 2

See figure 2. Position the barrel (1) in a press with the large end turned down and insert tool figure T-1 in the splined shaft hole in the barrel.

Place stop (3) and spring (4) over shaft (2) in the same sequence as shown.

Insert shaft (2) in barrel (1) and rest on tool figure T-1. Position the spring retainer (5) over the shaft (2) and against spring (4).

Carefully place tool, figure T-2, with the large end of the tapered hole up, over the shaft (2) and against the barrel face (1). Insert ring (6) around the shaft (2) and in the tool.

Position the ring with the gap within 5/8", 16 mm of the notch in the barrel for easy removal.

Place tool, figure T-3, over the shaft (2) with the small end against ring (6). Press on the end of the assembly tool and seat the ring (6) in the groove of the barrel (1).

Remove the assembly tools. Check to be sure that the ring is properly seated. Check barrel face to be certain it is not marred.

**PARTS LIST FOR FIGURE 2**

S13-43654 P6 COMPLETE BARREL AND SHAFT ASSEMBLY

S13-42316 P7 COMPLETE BARREL AND SHAFT ASSEMBLY

S23-12717 P8 COMPLETE BARREL AND SHAFT ASSEMBLY

item	description	part no.	quantity		
			P6	P7	P8
1	barrel & sleeve ass'y (P6)	S13-43657	1	-	-
	barrel & sleeve ass'y.(P7)	S13-47511	-	1	-
	barrel & sleeve ass'y (P8)	S23-12718	-	-	1
2	auxiliary drive shaft	033-53956	1	1	1
3	stop	033-53944	1	1	1
4	barrel holddown spring	033-70493	1	1	1
5	spring retainer	033-53945	1	1	1
6	retaining ring	033-70494	1	1	1

Consult DENISON HYDRAULICS Service for parts prior to 1983 units

## ASSEMBLY PROCEDURES

### PARTS LIST FOR FIGURE 3

rocker cam, pistons and retainer

item	description	mounting→ part no.	SAE-127-2		SAE-152-4	
			cw	ccw	cw	ccw
1	retaining ring (black) .077", 1,96 mm	033-54826	1	1	1	1
	retaining ring (red) .079", 2,01 mm	033-70490				
	retaining ring (green) .081", 2,06 mm	033-70488				
	retaining ring (yellow) .083", 2,11 mm	033-70484				
	retaining ring (blue) .085", 2,16 mm	033-72176				
	retaining ring (white) .087", 2,21 mm	033-72175				
2	thrust washer	033-72249	1	1	1	1
4	piston & shoe assembly w/retainer	see below	1	1	1	1
5	creep plate	033-71261	1	1	1	1
*6	button hd. screw	353-25041	2	2	2	2
*6a	set screw	312-09032	2	2	2	2
*7	servo stem	033-71312	1	1	1	1
*8	orifice screw (P & D only)	033-70819	2	2	2	2
	orifice screw in off-stroke port (V)	033-70819	1	1	1	1
*9	servo plate	033-53874	1	1	1	1
*10	hex. hd. screw 7/16-14 x 2-1/2"	306-40183	4	4	4	4
*11	hex. hd. screw 1/4-20 x 1-1/4"	306-40188	4	4	4	4
*12	hex. hd. screw 1/4-20 x 2-1/4"	306-40187	4	4	4	4
*13	hex socket plug SAE-4	488-35001	2	2	2	2
*14	O-ring 90 S-1 ARP 904	691-00904	2	2	2	2
*15R	right side chamber cover CW rot.	033-70572	1		1	
	right side chamber cover CCW rot.	033-70612		1		1
*15L	left side chamber cover CW rot.	033-70571	1		1	
	left side chamber cover CCW rot.	033-70574		1		1
*16	dowel pin 1/4" x 1-1/2"	324-21624	4	4	4	4
*17	chamber	033-72266	2	2	2	2
*18	seal	606-25036	2	2	2	2
*19	steel ball 3/16" H & G.	201-06001	4	4	4	4
*20	rocker cradle (SAE-"C" flange)	033-53951	1	1		
	rocker cradle (SAE-"D" flange)	033-92281			1	1
*21	vane spring (D & V units)	033-72233	8	8	8	8
*22	hold down vane (P units)	033-70816	4	4	4	4
	hold down vane (D & V units)	033-72232				
*23a	seal backup plate	033-70802	4	4	4	4
*23b	vane seal	033-70501	2	2	2	2
*23c	O-ring 90 S-1 ARP 120	691-00120	2	2	2	2
*23d	spacer	033-70519	2	2	2	2
*23e	check valve	033-70803	2	2	2	2
*24	rocker cam (P units)	S23-12105	1	1	1	1
	rocker cam (D & V units)	S23-12104				
25	pressure tube	033-70524	2	2	2	2

**\*Note:** Items 6 through 24 can be ordered as a complete rocker cam & control stroking assembly.

### CAM/CRADLE ASSEMBLIES

items 6 through 24, figure 3

#### SAE 127-2 (C) flange

P units	V units	D units	description
S23-01378	S23-11551	S23-01382	RH pumps w/B suffix (input control on RH side)
S23-01379	S23-11552	S23-01383	LH pumps w/B suffix (input control on RH side)
S23-01376	S23-11549	S23-01380	RH pumps w/A suffix (input control on LH side)
S23-01377	S23-11550	S23-01381	LH pumps w/A suffix (input control on LH side)

#### SAE 152-4 (D) flange

P units	V units	D units	description
	S23-15834	S23-15836	RH pumps w/B suffix (input control on RH side)
	S23-15833		RH pumps w/A suffix (input control on LH side)
			RH pumps w/A suffix (input control on LH side)
			LH pumps w/A suffix (input control on LH side)

### PISTON/SHOE/RETAINER ASSEMBLIES

item 4 figure 3

item	description	P6P,P6D	P6V	P7P,P7D	P7V	P8P,P8D,P8V	QTY.
4	piston/shoe ass'y/retainer	S13-43655	S13-45375	S13-42308	S13-47873	S21-11650	1
4a	shoe retainer	033-54290	033-54290	033-54290	033-54290	033-57376	1
4b	piston/shoe ass'y	S13-45680	S13-45372	S13-46040	S13-47872	S21-11649	7

**ROCKER CAM/PISTONS AND  
RETAINER**

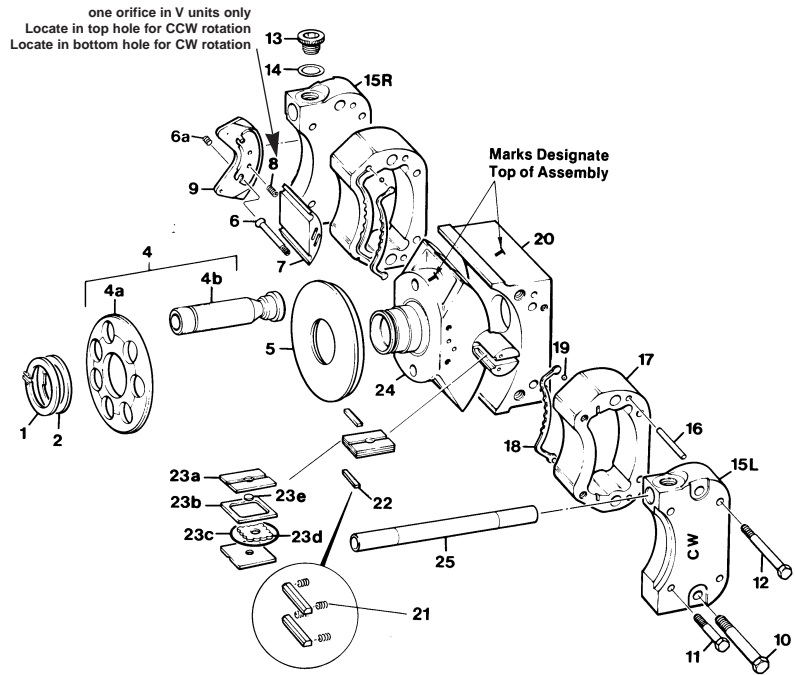

**ROCKER CAM ASSEMBLY**

**See figure 3.** Position the cradle (20) on a clean flat surface with the large flat area down.

Position the rocker cam (24) on the cradle (20). Note marks made earlier to indicate top of rocker cam & cradle.

Place O-ring (23b) around spacer (23d) and insert in the vane seal (23b).

Insert check valve (23e) inside of spacer (23d) and assemble between the two backup plates (23a) with the notched V's exposed.

Install assembled cartridge in slot in cam as indicated in figure 3. Repeat on opposite side of cam.

Insert the four holddown vanes (22) and springs (21) (D & V units) in the slots on each side of the control vanes (23).

Position both control chambers (17) on a clean flat surface with seal grooves turned up. Drop the four steel balls (19) in the four counterbored holes at each end of the seal grooves.

Lubricate seals (18) and insert in seal grooves in control chamber (17). The tapered side of the seals must be pushed into the grooves and the ends must cover the steel balls.

Install the control chamber (17) with seal (18) and steel balls (19) assembled over the control vane (23). The seal must be against the cam. Rotate the chamber until it passes over the control vane assembly, then rotate in the opposite direction until the 1/4" dowel pins (16) can be pushed through the chamber (17) and into the cradle (20). Install chamber in the same manner on the other side of the cam.

Two sets of chamber covers are available. The set marked CW must be installed in the right hand rotation pump, and the set marked CCW must be used in the left hand rotation pump. (Rotation is determined facing the pump shaft end). The covers must be installed with the tubing holes and the tapped holes at the top of the unit. Install chamber covers (15R) and (15L) on the control chambers (17) over the dowel pins (16). Referring to the "T" marked on the rocker cam (24) and cradle (20), the tapped holes must be at the top.

Install four 1/4 - 20 screws, two (11) and two (12) in each side and torque to 10 ft. lb., 13,56 Nm.

Install two 7/16 - 14 screws (10) in each side and torque to 45 ft. lb., 61 Nm.

**ROCKER CAM ASSEMBLY***(continued)*

Install O-ring (14) and plug (13) in each cover.

Install tubes (25) in reamed holes in each cover. These tubes must be a tight fit. If tubes are loose, the ends can be expanded with a tapered punch.

Tap the tubes in place with a plastic mallet.

For "P" and "D" units, install two orifice screws (8) in the servo stem (7). For "V" units, install one orifice, as indicated in figure 3.

Install servo plate with the end of the screws (6) through the servo stem. The orifice screw end of the servo stem must be against the servo plate.

Position the stem and plate on the rocker cam input side at 9 o'clock position on "B" suffix, or 3 o'clock for "A" suffix models with the screws positioned over the 10-24 tapped holes. Torque the screws (6) to 40 in. lb., 4,5 Nm. Install setscrews (6a) and torque to 5 ft. lb., 6,8 Nm. Caution: The set screws must not protrude from the servo plate.

**PISTON AND SHOE ASSEMBLY**

Install creep plate (5) over center post on rocker cam with small O.D. of plate turned toward cam.

Insert the seven piston and shoes (4b) in the shoe retainer (4a). Position the assembly (4) over the center post and against the creep plate.

Install thrust washer (2) over center post.

Six different retaining rings (1) are available for the holddown assembly. Each ring is marked: white dot .087", 2,21 mm thick, blue dot .085", 2,16 mm thick, yellow dot .083", 2,11 mm thick, green dot .081", 2,06 mm thick, and red dot .079", 2,01 mm thick, and black dot .077", 1,96 mm thick. Install the thickest ring (1) with the dot up, that will fit in the groove on the center post and allows a maximum clearance of .002"-.004", 0,051-0,102 mm between the shoe and creep plate while grasping one piston and lifting tightly against the shoe retainer.

The piston and shoe assembly (4) must be free to rotate easily by hand. The assembly must be rotated through 360° to confirm there is no binding and that each shoe is always free in the retainer plate. Oil the assembly thoroughly.

Position the cradle and cam assembly with the piston and shoe assembly attached with "T" marked on the cradle turned up.



**MOUNTING FLANGE, CAM & CRADLE, BARREL & AUX. SHAFT ASSEMBLY**

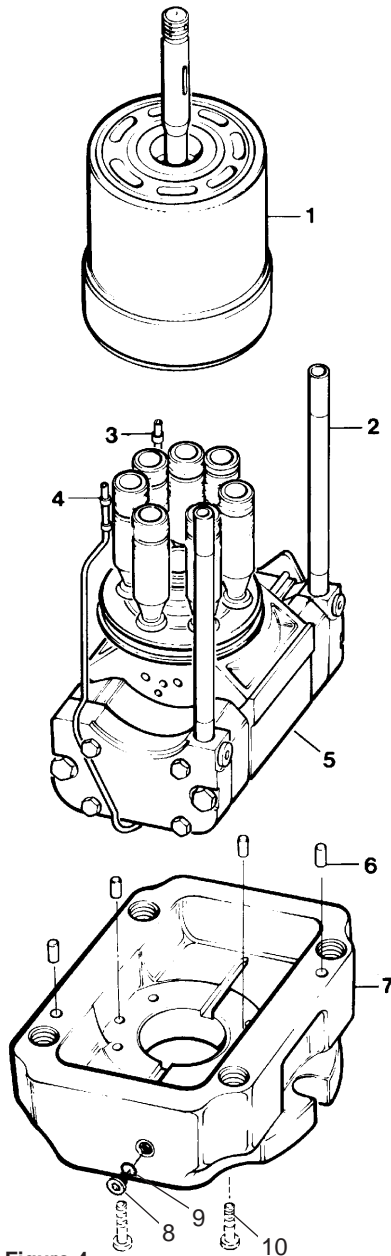

Figure 4

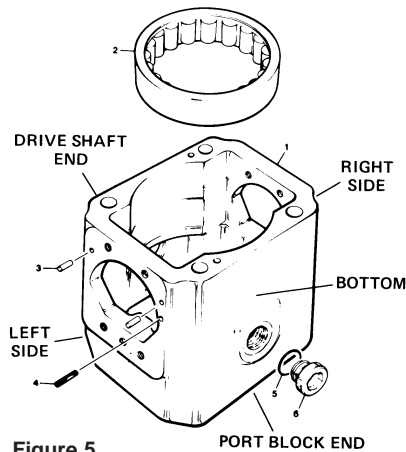

Figure 5

**See figure 4:** Insert tube line assemblies (3 and 4) in the holes provided in cradle. Note: Tube assemblies must be a snug fit into holes in cradle. Expand end of tubes with a pointed tool to assure fit.

Position the mounting flange (7) with the large open end up, and install two dowel pins (6) in the cradle mounting surface of the flange and two dowel pins (6) in the outer edge of the flange. Install plugs and O-rings (8) and (9) (after '96).

Install rocker cam and cradle assembly over the two dowel pins (6) in the mounting flange. Be certain that cradle is seated over the pins and against the flange with the tube lines (3) and (4) in the grooves in the flange.

Position the mounting flange, with the rocker cam assembly installed, on the top or bottom side and install screws (10) through the seal retainer area and into the cradle. (For the 127-2 flange, these will later be removed) Be certain the cradle is fully seated in flange. Torque to 14 ft-lb, 19 Nm. (152-4 flange only) Return the assembly to an upright position with the mounting flange down.

Tilt the rocker cam to either extreme position in the cradle. Position the barrel assembly with auxiliary shaft (1) directly over the pistons. Start with the uppermost piston and guide them one at a time into the barrel. Return the rocker cam to a level position in the cradle.

**PARTS LIST FOR FIGURE 4**

*mounting flange, rocker cam, pistons & retainer, barrel & auxiliary shaft assy.*

item	description	SAE flange →		
		part no.	127-2 qty.	152-4 qty.
1	barrel and auxiliary shaft assy.	see fig. 2	1	1
2	pressure tube	033-70524	2	2
3	tubing assembly (right side)	S13-42402	1	1
4	tubing assembly (left side)	S13-42403	1	1
5	rocker cam and stroking assembly	see fig. 3	1	1
6	dowel pin 3/8" x 3/4"	324-22412	4	1
7	mounting flange, SAE 127-2 (C)	033-70604	1	
	mounting flange, SAE 152-4 (D)	033-92280		1
8	hollow hex plug, SAE-4 (after '96)	488-35061	2	2
9	O-ring, 90 S-1 ARP 904 (after '96)	691-00904	2	2
10	screw, SHC, 1/4-20 UNC x 1-1/2" lg.	358-12200	4	*4

\*On pumps with SAE flange 127-2 (C), these screws are required to hold the rocker cam assembly in place and will be removed later.

**HOUSING ASSEMBLY**

**See figure 5:** Wash and dry all parts. During assembly, lapped and ground surfaces should be kept lubricated with clean oil and protected from nicks or surface damage. Position housing (1) on a clean flat surface with the large open end up.

Clean housing (1) and barrel bearing (2). Apply loctite® primer grade "T" and loctite® retaining compound #609 to bearing O.D. and bearing bore of housing. Rest housing on mounting flange end.

Position notch in bearing (2) in alignment with retainer hole in the housing bore. Insert pressing plug tool (figure T-4) in the bearing. With smooth and steady force, press the bearing into the housing bore until seated. **DO NOT HAMMER OR BEAT INTO PLACE.**

Install bearing retainer (7) with O-ring (8). Torque to 50 lb. ft., 68 Nm.

Turn housing (1) on side and install spring pin (4) in the 1/4" through hole in the control cover pad. The pin must be 3/8", 9,5 mm below the pad surface. **THE PIN MUST NOT INTERFERE WITH THE INTERNAL BEARING CAGE.** Install two dowel pins (3) in the blind holes in the same pad. Repeat previous step on the opposite side of the housing.

Place O-ring (5) on plug (6) and install in bottom of housing (1), adjacent to bearing retainer (7).

**PARTS LIST FOR FIGURE 5**

*S13-42335 housing assembly*

item	description	part no.	qty.
1	housing	033-91108	1
2	bearing	033-91107	1
3	dowel pin	324-21608	4
4	spring pin	325-16280	2
5	O-ring 90 S-1 ARP 912	691-00912	1
6	hollow hex plug SAE-12	488-35014	1
7	bearing retainer	033-91106	1
8	O-ring 90 S-1 ARP 908	691-00908	1



**HOUSING, END CAP, CAM AND BARREL ASSEMBLY**

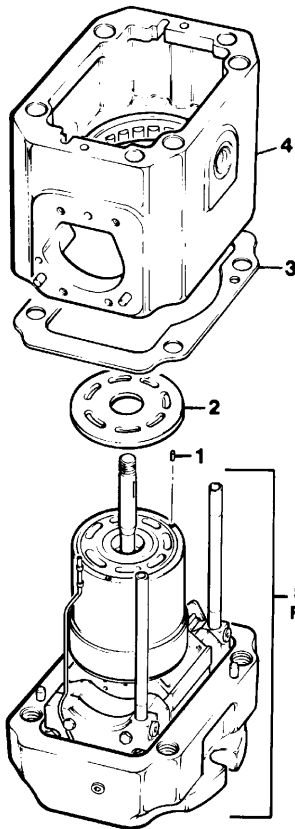

Figure 6

See figure 6: Install the three face plate pins (1) in the holes provided in the barrel face.

Apply heavy grease to the face of the barrel and install the face plate (2) over the pins (1) in the barrel.

Make certain the face plate is properly seated on the barrel and pins with the steel side towards the barrel face. The face plates have only one side bronzed and this must be towards the port plate. If necessary, remove coating from edge of face plate to determine bronze side.

Install gasket (3) over the two dowel pins (item 6 on figure 4) in the mounting flange.

Position the housing assembly (4) over the barrel and auxiliary shaft assembly and carefully guide the pressure tubes and tube lines (items 2, 3, and 4 on figure 4) through the housing assembly (4).

**PARTS LIST FOR FIGURE 6**

(housing, end cap, cam and barrel assembly)

item	description	part no.	qty.
1	face plate pins	033-49825	3
*2	barrel face plate P6 only	033-71530	1
	barrel face plate P7 and P8	033-72532	
3	housing gasket	033-91067	1
4	housing assembly (figure 5)	S13-42335	1
5	mtg. flange, cam, barrel assembly	see fig. 4	1

\*Note: item 2 arcuate port width: P6= 13/32", 10,3 mm P7 & P8=1/2", 12,7 mm

**PORT BLOCK ASSEMBLY**

See Figure 7: Position the port block (1) on a clean flat surface with the two open ports up. **THE OPPOSITE FACE MUST NOT BE SCRATCHED OR DAMAGED.** Position needle bearing (2) on tool (figure T-5) with the marked end of the bearing against the shoulder on the tool and press the bearing (2) into the port block. The bearing must be .010" - .025", 0,254 - 0,635 mm below the surface.

Thread socket pipe plugs (8) into port block.

Place O-ring (10) on hollow hex plug (9) and thread into tapped hole in top of port block.

**For "P" and "D" units:**

Slip check ring (3) into the two 1.50" ports and align holes in the ring with the side holes in the port wall. Place lock washers (6) on special screws (5). Insert screws (5) through port wall and drilled holes in checks (3) and thread into clamps (4). Torque to 10 ft. lb. 13.6 Nm. Thread two check valve assemblies (7) into valve face of port block.

**For "V" units:**

Align hole in solid ring (3) with 1-1/2" hole in port wall. Press ring into port till flush with surface. Align hole in solid ring (11) with 2" hole in port wall. Press ring into port till flush with surface. Thread soc. setscrew (12) into valve face of port block, on the "B" port side only.

**PARTS LIST FOR FIGURE 7**

S13-42386 "P" & "D" units

S23-00461 "V" units

item	description	part no.	qty.
1	port block (P & D units)	033-71296	1
	port block (V units)	033-71911	1
2	needle bearing	230-82146	1
3	check ring (P & D units)	033-70502	2
	solid ring (V units)(B port side)	033-57893	1
4	clamp (P & D units)	033-70489	2
5	special screw (P & D units)	033-70908	2
6	lock washer #10 (P & D units)	348-10016	2
7	check valve assembly (P & D units)	S13-40266	2
8	soc. pipe plug, 1/4"	431-90404	2
9	hollow hex plug, SAE-6	488-35041	1
10	O-ring 70 S-1 ARP 906	691-00906	1
11	solid ring (V units)(A port side)	033-91180	1
12	socket setscrew, 3/8-24 x 1/2 (V units, B port side)	353-25037	1

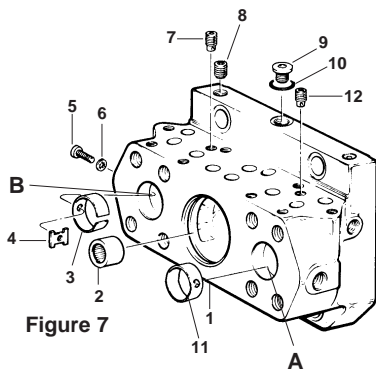

Figure 7

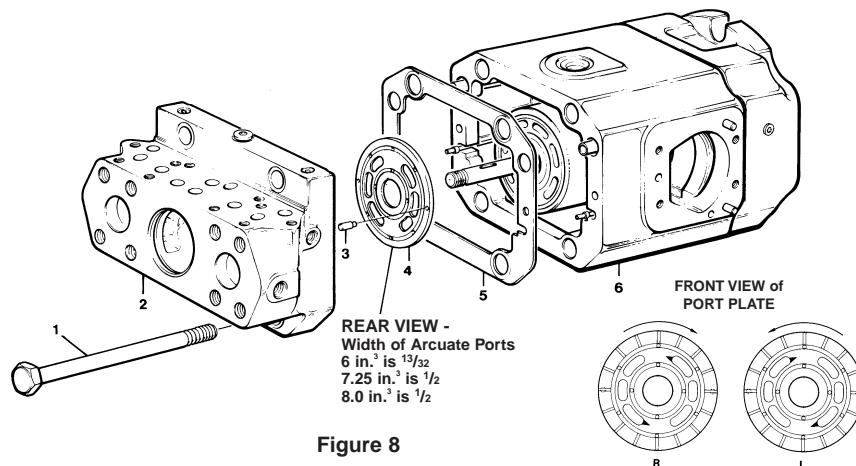

Figure 8

**MOUNTING PORT BLOCK TO HOUSING ASSEMBLY**

See figure 8: Position the pump with the unplugged hole in the housing assembly at 12 o'clock position.

Install gasket (5) on the housing assembly (6).

Install the two special pins (3) in the face of the port block assembly. Apply petroleum jelly or heavy grease to the plate (4) and position port plate over the pins (3) on the port block. Caution: For open circuit pumps (V units), be certain to position the port plate with the open port (no tie web) over the open port "A".

Slide the port block assembly and port plate over the end of the auxiliary shaft. Be certain that tubes 2, 3 and 4 shown on figure 4 are engaged and that the port plate (4) is still on the pins (3).

When the pump is properly assembled, the valve mounting surface will be at the top of the unit.

Install the four bolts, (1), and torque to 225 ft. lb., 305 Nm. Caution: use care to prevent damage to the valve mounting surface while installing and torquing the two top bolts.

**PARTS LIST FOR FIGURE 8**

mounting port block to housing assembly

item	description	part no.	qty.
1	hex head cap screw 5/8-11 x 9"	306-40182	4
2	port block ass'y	Fig. 7	1
3	port plate pins	033-49825	2
4	RH port plate 6.0 in <sup>3</sup> (P & D units)	033-71526	1
	RH port plate 6.0 in <sup>3</sup> (V units)	031-59368	
	LH port plate 6.0 in <sup>3</sup> (P & D units)	033-71525	
	LH port plate 6.0 in <sup>3</sup> (V units)	031-59333	
	RH port plate 7.25 in <sup>3</sup> (P & D units)	033-72811	
	RH port plate 7.25 in <sup>3</sup> (V units)	031-54509	
	LH port plate 7.25 in <sup>3</sup> (P & D units)	033-53776	
	LH port plate 7.25 in <sup>3</sup> (V units)	031-54508	
	RH port plate 8.0 in <sup>3</sup> (P & D units)	033-91252	
	RH port plate 8.0 in <sup>3</sup> (V units)	031-57379	
	LH port plate 8.0 in <sup>3</sup> (P & D units)	033-91553	
	LH port plate 8.0 in <sup>3</sup> (V units)	031-57372	
5	port block gasket	033-91060	1
6	housing/flange ass'y	Fig. 6	1

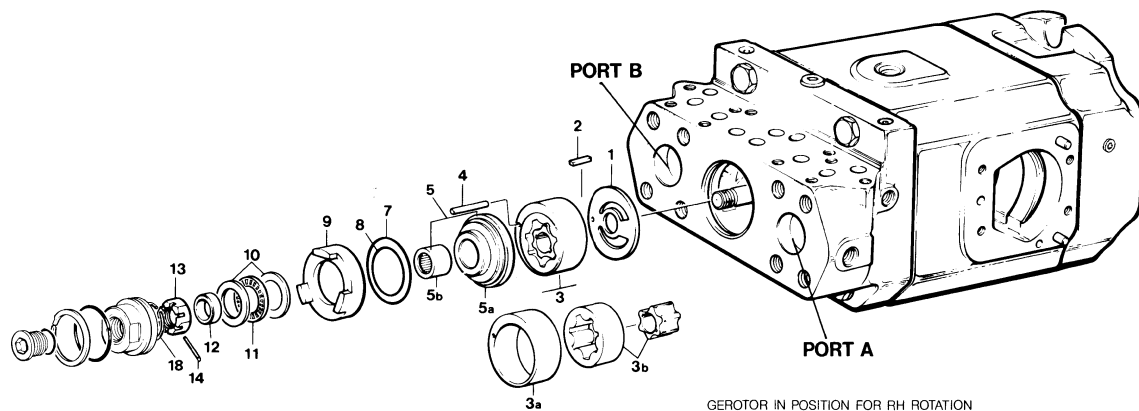

Figure 9

### GEROTOR AND BARREL HOLD-DOWN

**See figure 9:** Position the unit with the shaft in a horizontal position and the valve block mounting surface turned up. Rotate the shaft until the small keyway in the auxiliary shaft is at 12 o'clock position.

If pump is being assembled for right hand rotation install dowel pin (4) in hole in port block at the 9 o'clock position when viewing from port block end of unit, if left hand pump, install at 3 o'clock position.

Install side plate (1), steel side first, over dowel pin. Insert key (2) in shaft keyway. Install the inner gear of the gerotor assembly (3c) on the shaft and over the key (2). Install the eccentric ring (3a) on the dowel pin (4). Install the large outer gear of the gerotor assembly (3b) inside the eccentric ring (3a) and over the inner gear.

Press needle bearing (5b) into gerotor side plate (5a) with the marked end of the bearing against the pressing tool (T-5).

The marked end of the bearing must be .010" to .025", 0,025 mm to 0,064 mm below the small diameter face of the side plate.

**Note:** When changing pump rotation consult parts list for proper side plate (5a)

Place O-rings (7) and (8) on side plate assembly. Lubricate the O-rings and slip the pressure plate (9) over the O-rings on the side plate assembly. Slip the two plates over the auxiliary shaft and position the gerotor side plate over the dowel pin (4).

Place seal ring (12) on auxiliary shaft. Position bearing (11) between the two thrust washers (10) and install around the seal ring (12). Thread holddown nut (13) on the shaft and tighten no more than 10 ft. lb., 13.6 Nm max. Back off the nut (13) until second slot is aligned with pin hole in the shaft. Insert pin (14) through nut and shaft and secure with ring (18).

Check the main shaft for smooth rotation. If not smooth, check the gerotor parts for position and holddown nut for proper adjustment.

Place O-ring (16) on end cover (15) and lubricate. Place end cover over holddown nut (13). Depress cover and install snap ring (17). Make certain that snap ring is properly seated in groove.

Install O-ring (19) on plug (20). Lubricate and install plug in end cover (15).

**PARTS LIST FOR FIGURE 9**

*gerotor and barrel holddown*

item	description	part no.	qty.
1	side plate	033-71492	1
2	square key 1/8 x 9/16	211-22034	1
3	gerotor and eccentric ring assy.	S13-43334	1
3a	eccentric ring	033-72256	
3b	inner and outer gerotor	033-71500	
4	dowel pin 3/16 x 1-9/16	324-21225	1
*5	gerotor sideplate and bearing assy.	see below	1
**5a	sideplate	see below	
5b	needle bearing Torrington B 1212	230-82146	
7	O-ring 70 S-1 ARP 144	671-00144	1
8	O-ring 70 S-1 ARP 129	671-00129	1
9	pressure plate	033-70531	1
10	thrust washer	350-10065	2
11	bearing Torrington NTA 1625	230-82131	1
12	seal ring	033-71490	1
13	holddown nut	033-53922	1
14	pin	033-53921	1
15	cover w/SAE-16 inlet	033-72100	1
16	O-ring 70 S-1 ARP 147	671-00147	1
17	internal snap ring Eaton 1N287	356-65082	1
18	retaining ring	033-53923	1
19	O-ring 90 S-1 ARP 916	691-00916	1
20	plug	488-35024	1

\*for RH pumps use S13-46762

\*for LH pumps use S13-46763

\*\*for RH pumps use 033-72258

\*\*for LH pumps use 033-72259

## ASSEMBLY PROCEDURES

### PARTS LIST FOR FIGURE 10

valve block assembly (before 7-93)

item	description	part no.	qty.
2	O-ring 70 S-1 ARP 014	671-00014	2
3	O-ring 70 S-1 ARP 013	671-00013	2
4	button hd. screw 10-24 x 1/2	353-25023	4
5	spring pin 1/8 x 3/4	325-08120	2
6	retainer plate	033-91422	1
7	lower gasket	033-91193	1
8	sequence seat	033-70507	2
9	valve seat (qty. 3 in PV only)	033-70500	4
10	spring pin 3/16 x 3/4	325-12120	2
11	valve block	033-72377	1
12	orifice plug .047", 1,2 mm	033-25528	4
13	sequence poppet	033-72378	2
14	valve poppet (qty. 3 in PV only)	033-72379	4
15	spring retainer	033-70482	1
16	spring (1" OAL)	033-71086	3
17	spring (1-7/16" OAL)	033-70512	2
18	spring (light weight) (P units)	033-22141	1
	spring (D units)	033-72693	
19	check valve assembly	S13-40266	2
21	valve cover (P units)	033-72376	1
	valve cover (D & V units)	033-72676	
22	O-ring 90 S-1 ARP 903	691-00903	1
23	seat	033-70508	1
24	cone	033-12288	1
25	spring	033-12289	1
26	O-ring 70 S-1 ARP 012	671-00012	1
27	seal piston	033-21767	1
28	O-ring 90 S-1 ARP 910	691-00910	1
29	housing	033-70545	1
30	hex nut 5/16-24	335-13100	1
31	soc. setscrew 5/16-24 x 1	312-13160	1
33	acorn nut	327-25006	1
34	servo strainer assembly	S13-43240	1
35	O-ring 90 S1 ARP 906	691-00906	1
36	hex plug SAE-6	488-35003	1
37	O-ring 70 S-1 ARP 050	671-00050	2
39	hex hd. cap screw 10-24 x 1-3/4	306-40167	4
40	dowel pin 1/8 x 5/8 (P units)	324-20810	1
	roller (D & V units)	230-82170	
41	pilot relief assy (P & D units)	S23-12699	1
42	O-ring 90 S-1 ARP 904	691-00904	5
43	hollow hex plug SAE-4	488-35001	5

#### ASSEMBLY NUMBER

**P6P/P7P/P8P** S23-11425

**P6D/P7D/P8D** S13-47748

**P6V/P7V/P8V** S13-48989

VALVE BLOCK ASSEMBLY

(before 7-93)

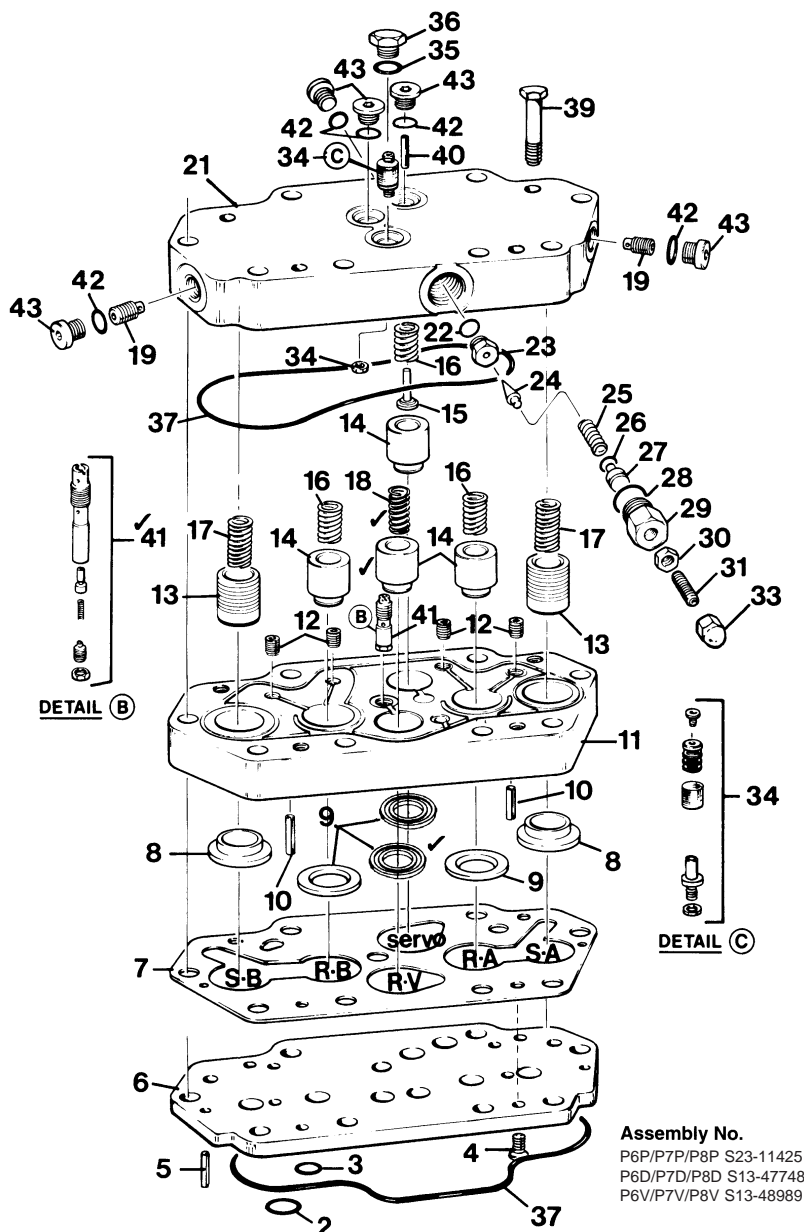

FIGURE 10 VALVE BLOCK ASSEMBLY (Before 7-93)

See figure 10:

**Note:** Prior to assembly of reconditioned parts, check finish of gasket surface on valve block and retainer. These must have 60 rms finish with no grinding marks which might carry oil to outside surface. If lapping is necessary, check depth of pockets for valve seats after lapping. These must be .085", 2,16 mm minimum after lapping, to provide clearance for valve seats.

Lubricate the four orifice plugs (12) and insert in the top of valve block (11).

Check the pilot valve assembly (41) to be certain that approximately 1-1/2 threads are exposed from the small nut on the bottom of the valve assembly. This setting will allow the valve to function at about 100 PSI, 6,8 bar. Each complete right hand turn of this screw will increase the pressure about 25 PSI, 1,7 bar. Torque hex lock nut to 20-25 in. lb., 2,26 - 2,82 Nm. Thread the check valve (41) into the 3/8-24 tapped hole into the valve block (11) as shown. ("V" units do not receive this valve assembly.)

Press the two spring pins (10) into the holes provided in the bottom of the valve block (11). The pins (10) must be .12", 0,3 mm below the surface.

**VALVE BLOCK ASSEMBLY***before 7-93 (continued)*

Place the two sequence seats (8) in the sequence ports (SB, SA). Place the four valve seats (9) in the ports marked RB, RA, RV, and servo. Install servo and RV seats with the groove down. Position the gasket (7) and retainer plate (6) over the seats and insert the four screws (4) in the block (11). Torque to 10 in. lb., 1,1 Nm.

Position the valve block and the attached parts with four orifices (12) turned up. Insert the two 1-7/16", 36,5 mm long springs (17) in the two sequence poppets (13) and install poppet (13) and (17) in the block and over the sequence seats (18) in ports SB and SA. Install the four valve poppets (14) in the ports marked RB, RA, RV and servo. Insert spring retainer (15), large end first, in the servo poppet. Insert the 1-9/16", 39,7 mm long light weight spring (18) in the RV poppet. Insert the three 1", 25,4 mm long springs (16) in poppets RB, RA and servo.

Lubricate the two check valves (19) and install in sides of cover (21).

Lubricate O-ring (22) and place on seat (23) and install in valve cover (21). Use a 1/2", 6 point 1/4" drive socket and torque to 15 ft. lb., 20,4 Nm. Do not use impact wrench. Lubricate O-rings (26) and (28) and place on parts (27) and (29). Assemble nuts (30) and (33) on screw (31) and start (31) into housing (29). Push seal piston (27) and O-ring (26) into housing (29) with the small end of the piston exposed. Place spring (25), 1.035" -1.065", 26,3-27,1 mm lg., on cone (24) and insert all these parts in the valve cover (21). Be certain that cone (24) enters seat (23).

Disassemble the strainer assembly (34) and reassemble per the following:

- a. Install the orifice screw of strainer assembly (34) into valve cover. Thread elastic stop nut onto the orifice screw and torque to 23 in. lb., 2,6 Nm.
- b. Install the strainer support, filter screen, and 6-32 x 1/4 lg. screw. Torque 6-32 screw to 13 in. lb., 1,47 Nm.

Position the cover (21) over the springs and poppets and install the four screws (39). **BE CERTAIN THAT THE SPRINGS ARE IN THE RIGHT POSITION BEFORE TIGHTENING THE SCREWS.**

Install dowel pin or roller pin (40) in the hole over the servo poppet. Lubricate the four O-rings (42) and place on the four plugs (43). Install the four plugs. Lubricate O-ring (35) and place on plug (36) and install. **CAUTION: USE OF OTHER THAN SAE PLUGS WILL RESULT IN MALFUNCTION AND POSSIBLE PUMP DAMAGE.**

Invert the complete assembly and install spring pins (5) through plate (6) and into the valve block. Install O-rings (2) and (3) in the plate (6).

VALVE BLOCK ASSEMBLY

(after 7-93)

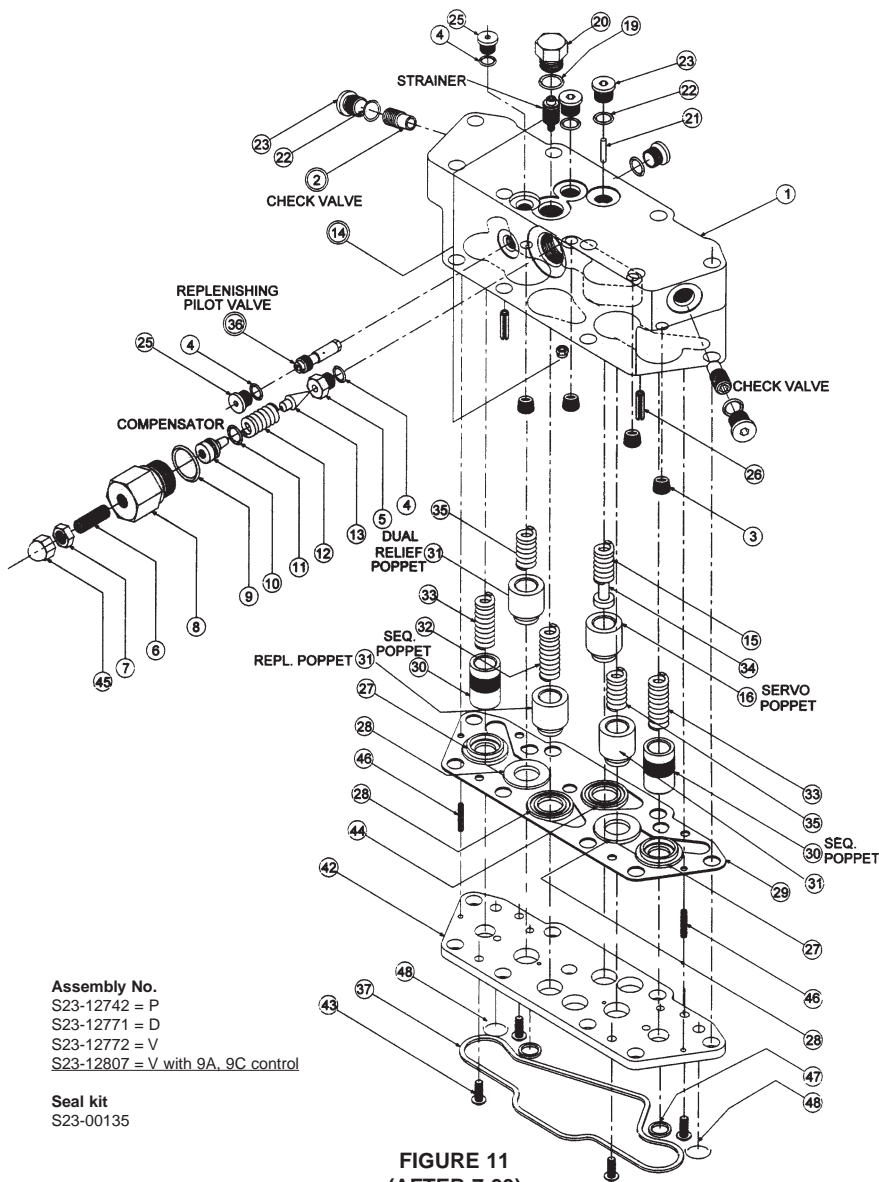

Assembly No.  
 S23-12742 = P  
 S23-12771 = D  
 S23-12772 = V  
 S23-12807 = V with 9A, 9C control

Seal kit  
 S23-00135

FIGURE 11  
 (AFTER 7-93)  
 VALVE BLOCK ASSEMBLY

See figure 11:

**Note:** Do not use impact tools or over tighten threaded parts.

Wash and dry all parts. During assembly, lapped and ground surfaces should be kept lubricated with clean oil and protected from nicks or surface damage.

Place valve block (1) with the six poppet valve bores up in order to press two spring pins (26) in position. Spring pins to be .12", 3,04 mm below the surface of valve block. **Note:** Spring pins are not required on assemblies after 8-96.

Install four orifice plugs (3) into valve block (1) and tighten in place.

Disassemble the strainer assembly (14) and reassemble per the following steps: (V and V/900 units do not use strainer)

a. Install the orifice screw of strainer assembly (14) into valve cover. Thread elastic stop nut onto the orifice screw and torque to 23 in. lb., 2,6 Nm.

b. Install the strainer support, filter screen, and 6-32 x 1/4 lg. screw. Torque 6-32 screw to 13 in. lb., 1,47 Nm.



**VALVE BLOCK ASSEMBLY***after 7-93 (continued)*

Place valve block with poppet valve bores facing up. Position gasket (29) on valve block.

Place springs (33), 1.43", 36.3 mm into outermost bores at each end of the valve block. Place sequence poppets (30) over these springs. Position seats (27) small shoulder side first over poppets.

Place springs (35), 1.09", 27.7 mm into bores next to the sequence poppet valves. Place dual relief poppet (31) over these springs. Position seats (28) with the groove side facing up, over poppets.

Place spring (32) 1.56", 39.6 mm long, into bore next to compensator valve side of block. (D units use 1", 25.4 mm long spring, V and V/900 units do not use replenish spring, poppet or seat.) Install replenish poppet over spring. Position seat (28) with the groove side facing down, over poppet.

Insert spring (15) 1.09", 27.7 mm long, (V/900 units use 1.43", 36.3 mm) into the remaining bore. Place spring retainer (34) in spring. (V/900 units do not use spring retainer) Place servo poppet (16) over the retainer and spring. Position seat (44) with the groove side facing down, over poppet. (V/900 units use seat with small shoulder towards the poppet).

Carefully position the retainer plate (42) over seats and poppets. Pressing with one hand on the valve block, compress seats, poppets and springs far enough to alternately thread two button head cap screws (43) in far enough to hold the retainer plate. Install the other two screws and alternately tighten screws. Torque to 30 lb. in., 3,39 Nm.

Lubricate O-ring (4) and install onto seat (5). Thread seat into valve block. (Be careful not to damage bore in seat.) Torque to 15 lb.-ft., 20,3 Nm.

Apply petroleum jelly to shank of cone (13) and install spring (12) on cone. Carefully insert cone and spring into valve block positioning point of cone into bore of seat.

Lubricate O-ring (11), install in groove of piston (10) and insert end into spring (12). Install piston in housing guide (8).

Lubricate O-ring (9) and install on housing guide (8) and thread into valve block. Tighten in place.

Thread nut (7) on socket set screw (6) and thread screw into housing guide (8) until it starts to compress spring. Install acorn nut (45) over end of soc. setscrew (6).

Using a small bladed screwdriver, thread the pilot replenishing relief valve assembly (36) into valve block and lightly tighten in place. (Do not over tighten. Over tightening can cause sides of slot to break now or at next removal.) (V and V/900 units do not use replenishing relief valve assembly.)

Lubricate O-ring (4) and install on plug (25) and tighten plug in place, two places.

Thread check valve (2) into valve block and lightly tighten in place. (Do not over tighten). Lubricate O-ring (22) and install on plug (23) and tighten in place.

Repeat on other end of valve block.

Lubricate O-ring (19) and install on plug (20) and tighten plug in place.

Install pin (21) (V/900 units do not use pin). Lubricate O-ring (22) and install over plug (23) and tighten in place.

Using a small hammer, carefully tap spring pins (46) into and through the retainer plate (42). The pins should bottom out in holes leaving enough length sticking out for piloting into the port block.

Lubricate O-ring (47), (48) and (37) and install in the bottom of retainer plate (42).

## ASSEMBLY PROCEDURES

### PARTS LIST FOR FIGURE 11

valve block assembly (after 7-93)

item	description	part no.	qty.			
			P	D	V	V/900
1	valve block, 1/8 pin	033-91221	1			
	valve block, 5/32 pin	033-91334		1	1	
	valve block, no pin	033-91338				1
2	check valve assembly	S13-40266	2	2	2	2
3	orifice plug .047" 1,2 mm	033-91249	4	4	4	4
4	O-ring 90 S-1 ARP 903	691-00903	3	3	3	3
5	seat	033-70508	1	1	1	1
6	soc. setscrew 5/16-24 x 1	312-13160	1	1	1	1
7	hex nut 5/16-24	335-13100	1	1	1	1
8	housing	033-70545	1	1	1	1
9	O-ring 90 S-1 ARP 910	691-00910	1	1	1	1
10	seal piston	033-21767	1	1	1	1
11	O-ring 70 S-1 ARP 012	671-00012	1	1	1	1
12	spring	033-91798	1	1	1	1
13	cone	033-12288	1	1	1	1
14	servo strainer assembly	S13-43240	1	1		
15	servo spring, 1.09", 27,7 mm	033-71086	1	1	1	
	servo spring, 1.43", 36,3 mm	033-70512				1
16	servo relief poppet	033-72379	1	1	1	
	servo relief poppet	033-54398				1
19	O-ring 90 S1 ARP 906	691-00906	1	1	1	1
20	hex plug SAE-6	488-35003	1	1	1	1
21	dowel pin 1/8 x 5/8	324-20810	1			
	roller 5/32 x 5/8	230-82170		1	1	
22	O-ring 90 S-1 ARP 904	691-00904	5	5	5	5
23	hollow hex plug SAE-4	488-35001	5	5	5	
	hex plug SAE-4	488-35013				5
25	plug	488-35049	2	2	2	2
26	*spring pin 3/16 x 3/4	325-12120	2	2	2	2
27	sequence seat	033-70507	2	2	2	2
28	repl. & dual relief seat	033-70500	3	3	2	2
29	gasket	033-91193	1	1	1	1
30	sequence poppet	033-72378	2	2	2	2
31	repl & dual relief poppet	033-72379	3	3	2	2
32	spring (1.56", 39,7 mm)	033-22141	1			
	spring (1.00", 25,4 mm)	033-72693		1		
33	spring (1.43", 36,3 mm)	033-70512	2	2	2	2
34	spring retainer	033-70482	1	1	1	1
35	spring (1.09", 27,7 mm)	033-71086	2	2	2	2
36	pilot relief assy	S23-12699	1	1		
37	O-ring 70 S-1 ARP 050	671-00050	1	1	1	1
42	retainer plate	033-91422	1	1	1	1
43	button hd. screw 10-24 x 3/4	353-25078	4	4	4	4
44	servo relief seat	033-70500	1	1	1	
	servo relief seat	033-54399				1
45	acorn nut	327-25006	1	1	1	1
46	spring pin 1/8x 3/4	325-08120	2	2	2	2
47	O-ring 70 S-1 ARP 013	671-00013	2	2	2	2
48	O-ring 70 S-1 ARP 014	671-00014	2	2	2	2

\*not used on assemblies built after 8-96

#### ASSEMBLY NUMBERS

- P** S23-12742 (standard closed circuit pumps)
- D** S23-12771 (open/closed circuit pumps)
- V** S23-12772 (open circuit pumps)
- V/900** S23-12807 (open circuit pumps with 9A2 or 9A4 control)

## ASSEMBLY PROCEDURES

### PARTS LIST FOR FIGURE 12

valve block assembly for special mounting of servovalve (before 7-93)

item	description	part no.	qty.
1	valve cover	033-54391	1
2	check valve assembly	S13-40266	2
3	orifice plug .047" 1,2 mm	033-25528	5
4	O-ring 90 S-1 ARP 903	691-00903	1
5	seat	033-70508	1
6	soc. setscrew 5/16-24 x 1	312-13160	1
7	hex nut 5/16-24	335-13100	1
8	housing	033-70545	1
9	O-ring 90 S-1 ARP 910	691-00910	1
10	seal piston	036-21767	1
11	O-ring 70 S-1 ARP 012	671-00012	1
12	spring	036-12289	1
13	cone	036-12288	1
14	servo strainer assembly	S13-43240	1
15	manifold	033-54389	1
16	spring (Lee LC-038C-19)	225-92083	1
19	O-ring 90 S1 ARP 906	691-00906	3
20	hex plug SAE-6	488-35041	3
21	gasket	035-47851	1
22	O-ring 90 S-1 ARP 904	691-00904	10
23	hollow hex plug SAE-4	488-35001	9
25	valve block	033-54390	1
26	spring pin 3/16 x 3/4	325-12120	2
27	sequence seat	033-70507	2
28	valve seat	033-70500	3
29	lower gasket	033-91193	1
30	sequence poppet	033-72378	2
31	valve poppet	033-72379	3
32	spring (light weight)	033-22141	1
33	spring (1- 7/16" OAL)	033-70512	3
34	servo relief poppet	033-54398	1
35	spring (1" OAL)	033-71086	2
36	pilot relief assy	S23-12699	1
37	O-ring 70 S-1 ARP 050	671-00050	2
38	spool	033-54392	1
39	O-ring 90 S-1 ARP 008	691-00008	1
41	soc. hd. cap screw 10-24 x 2-3/4	358-10300	4
42	retainer plate	033-91422	1
43	button hd. screw 10-24 x 1/2	353-25023	4
44	servo relief seat	033-54399	1
45	acorn nut	327-25006	1
46	spring pin 1/8 x 3/4	325-08120	2
47	O-ring 70 S-1 ARP 013	671-00013	6
48	O-ring 70 S-1 ARP 014	671-00014	2
49	plug 3/4-16	449-00016	2
50	plug 7/16-20	449-00013	1
51	gasket, cover	035-47852	1
52	screw, soc. hd. 10-32 x 1/2	359-09080	4
53	screw, soc. hd. 3/8-16 x 4	358-16360	4
54	plug	035-54400	1
55	hex hd. screw	306-40132	4

**ASSEMBLY NUMBER S23-11433**

**SEAL KIT S23-04226**

**VALVE BLOCK ASSEMBLY**

for special mounting of servovalve  
(before 7-93)

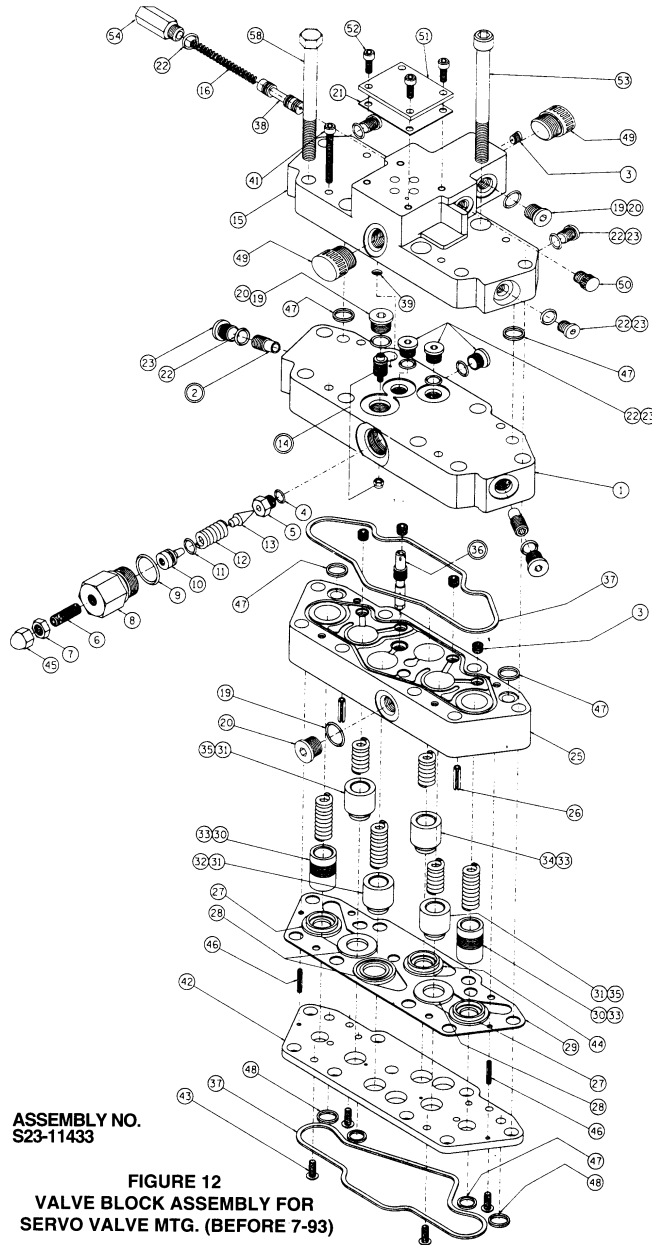

ASSEMBLY NO.  
S23-11433

**FIGURE 12**  
**VALVE BLOCK ASSEMBLY FOR**  
**SERVO VALVE MTG. (BEFORE 7-93)**

**See figure 12:**

**Note:** Prior to assembly of reconditioned parts, check finish of gasket surface on valve block and retainer. These must have 60 rms finish with no grinding marks which might carry oil to outside surface. If lapping is necessary, check depth of pockets for valve seats after lapping. These must be .085", 2,16 mm minimum after lapping, to provide clearance for valve seats.

Wash and dry all parts. During assembly, lapped and ground surfaces should be kept lubricated with clean oil and protected from nicks or surface damage.

Place valve block (25) with O-ring groove down and horizontal in order to press two spring pins (26) in position. Spring pins to be .12", 3,04 mm below the surface of valve block.

Apply a liberal amount of petroleum jelly or grease to the six counterbores in the face of the valve block (25). Install two valve seats (27) tapered bore side first, into counterbores and against spring pin (26), one required each end, (outer-most counterbores in block). Insert the valve seats (28) and valve seat (44) in remaining counterbores as shown.

Press two spring pins (46) into retainer plate (42). Each spring pin should stick out approximately .25", 6,35 mm from each face of the retainer plate.

**VALVE BLOCK ASSEMBLY**

for special mounting of servovalve  
(before 7-93) (continued)

Position valve block gasket (29) on valve block. Take care that none of the gasket is covering the valve seats.

Position retainer plate (42) with O-ring grooves facing up, over valve block gasket. Install four button head cap screws (43), torque to 30 in. lb., 3,39 Nm.

Turn the assembly over so that it is resting with the retainer plate O-ring side downward.

Place spring (33) 1.43", 36,3 mm long into poppet (30) and insert small hole end first into outermost bores at each end of the valve block (25).

Insert three poppets (31) and one poppet (34) into remaining bores as shown, small diameter end first.

Slip springs (33) into poppets (34) and (30) as shown.

Insert two springs (35), 1.09", 27,7 mm long into remaining outer poppets (31).

Install spring (32) 1.56", 39,6 mm long into remaining poppet located in center of valve block.

Install four orifice plugs (3) in valve block (25) and tighten in place.

Thread pilot replenishing relief valve (36) into block (25). Valve must not extend below lower surface of retainer plate.

Place O-ring (4) onto seat (5) and install in valve block cover (1). Be careful not to damage bore in seat. Torque to 15 ft.-lb., 20,4 Nm. **Do not use impact wrench.**

Lubricate O-ring (11) and insert into groove of seal piston (10) and slip spring (12) onto end of seal piston and press into bore of housing guide (8).

Lubricate O-ring (9) and install on housing guide (8).

Place shank of cone (13) into spring (12). Align cone with seat in valve cover, thread housing guide into bore and tighten in place.

Thread nut (7) on socket setscrew (6) and thread into housing guide (8) until it starts to compress spring. Thread acorn nut (45) onto socket setscrew (6).

Coat check valve (2) threads with Loctite® threadlocker #242 and thread into end of valve cover (1). **Be sure check valve is properly installed and does not block orifice.** Lubricate O-ring (22) and install on plug (23) and tighten.

Repeat on the opposite end of valve cover (1)

Disassemble the strainer assembly (14) and reassemble per the following steps:

- a. Install the orifice screw of strainer assembly into valve cover. Thread elastic stop nut onto the orifice screw and torque to 23 in. lb., 2,6 Nm.
- b. Install the strainer support, filter screen, and 6-32 x 1/4 lg. screw. Torque screw to 13 in. lb., 1,47 Nm.

Place O-ring (37) and two O-rings (47) into the grooves on the upper surface of the valve block and secure with petroleum jelly or grease.

Place valve cover (1) over valve block (25) positioning over springs (33), (32) and (35) and secure in place with four socket hd. cap screws (41).

Lubricate O-ring (22) and install on plug (23) and tighten in place.

Lubricate O-ring (19) and install over plug (20) and tighten plug in place.

Lubricate O-rings (47) and install in underside of manifold block (15) on top of the valve cover (1) making sure the O-rings are correctly seated. Secure with four socket hd. cap screws (41) by threading into valve block (25).

Insert spring (16) and spool (38) into manifold (15) with the spring guide and spring towards the left side of the manifold (15) when viewing from the top rear.

Install temporary plugs (49) and (50) in 1/2" tube and 1/4" tube ports, front and back side. Insert O-ring (19) and plug (20) into alternate drain port.

**VALVE BLOCK ASSEMBLY**

for special mounting of servovalve  
(after 7-93)

Assembly No.

S23-12776 w/o shutoff

(control feature 00)

S23-12798 w manual shut-off

(control feature 01)

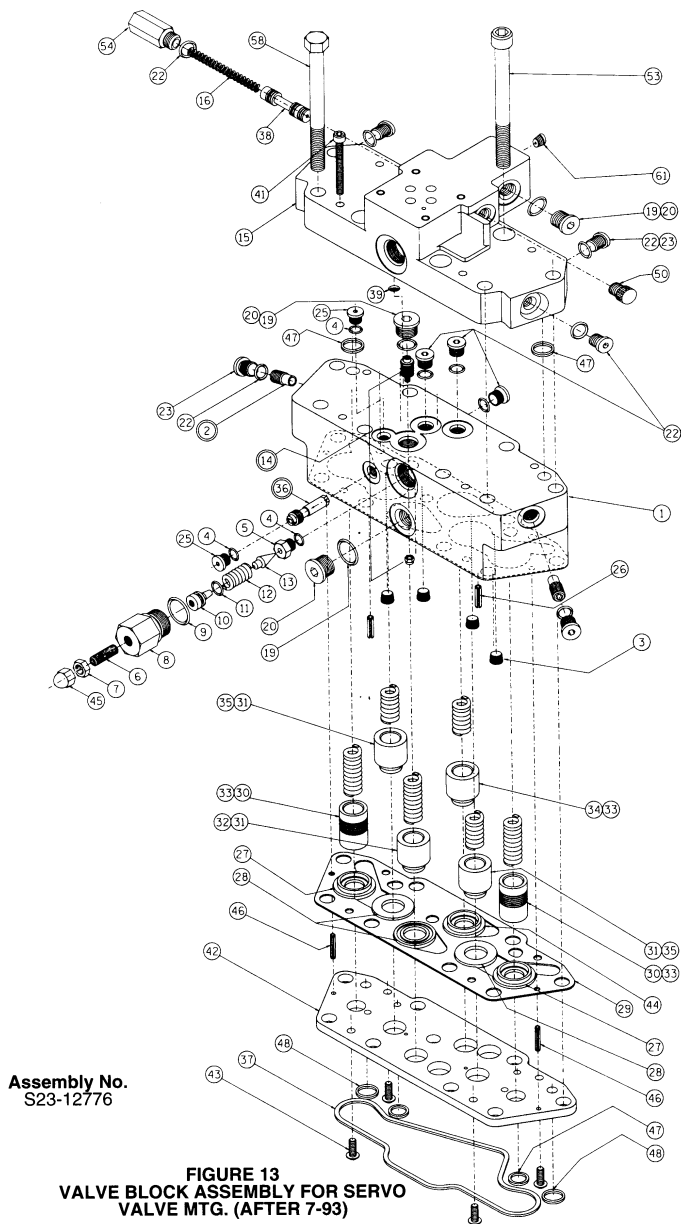

Assembly No.  
S23-12776

**FIGURE 13**  
**VALVE BLOCK ASSEMBLY FOR SERVO**  
**VALVE MTG. (AFTER 7-93)**

See figure 13:

**Note: Do not use impact tools or over tighten threaded parts.**

Wash and dry all parts. During assembly, lapped and ground surfaces should be kept lubricated with clean oil and protected from nicks or surface damage.

Place valve block (1) with the six poppet valve bores up in order to press two spring pins (26) in position. Spring pins to be .12", 3,04 mm below the surface of valve block. Spring pins are not required on assemblies after 8-96.

Install four orifice plugs (3) into valve block (1) and tighten in place.

Disassemble the strainer assembly (14) and reassemble per the following steps:

- a. Install the orifice screw of strainer assembly (14) into valve cover. Thread elastic stop nut onto the orifice screw and torque to 23 in. lb., 2,6 Nm.
- b. Install the strainer support, filter screen, and 6-32 x 1/4 lg. screw. Torque 6-32 screw to 13 in. lb., 1,47 Nm.

Place valve block with poppet valve bores facing up. Position gasket (29) on valve block.

**VALVE BLOCK ASSEMBLY**

*for special mounting of servovalve after 7-93 (continued)*

Place springs (33), 1.43", 36,3 mm into outermost bores at each end of the valve block. Place sequence poppets (30) over these springs. Position seats (27) small shoulder side first over poppets.

Place springs (35), 1.09", 27,7 mm into bores next to the sequence poppet valves. Place dual relief poppet (31) over these springs. Position seats (28) with the groove side facing up, over poppets.

Place spring (32) 1.56", 39,6 mm long into bore next to compensator valve side of block. Install replenish poppet (31) over spring. Position seat (28) with the groove side facing down, over poppet.

Insert spring (33) 1.43", 36,3 mm into the remaining bore. Place servo poppet (34) over the retainer and spring. Position seat (44) with the tapered bore facing down, over poppet.

Carefully position the retainer plate (42) over seats and poppets. Pressing with one hand on the valve block, compress seats, poppets and springs far enough to alternately thread two button head cap screws (43) in far enough to hold the retainer plate. Install the other two screws and alternately tighten screws. Torque to 30 lb. in., 3,39 Nm.

Lubricate O-ring (4) and install onto seat (5). Thread seat into valve block. (Be careful not to damage bore in seat.) Torque to 15 lb.-ft., 20,3 Nm.

Apply petroleum jelly to shank of cone (13) and install spring (12) on cone. Carefully insert cone and spring into valve block positioning point of cone into bore of seat.

Lubricate O-ring (11), install in groove of piston (10) and insert end of piston into spring (12). Insert piston (11) into housing guide (8).

Lubricate O-ring (9) and install on housing guide (8) and thread into valve block. Tighten in place.

Thread nut (7) on socket set screw (6) and thread screw into housing guide (8) until it starts to compress spring. Install acorn nut (45) over exposed threads.

Using a small bladed screwdriver, thread the pilot replenishing relief valve assembly (36) into valve block and lightly tighten in place. (Do not over tighten. Over tightening can cause sides of slot to break now or at next removal.)

Lubricate O-ring (4) and install on plug (25) and tighten plug in place, two places.

Thread check valve (2) into valve block and lightly tighten in place. (Do not over tighten). Lubricate O-ring (22) and install on plug (23) and tighten in place. Repeat on other end of valve block.

Lubricate O-rings (19) and install on plugs (20) and tighten plug in place, three places. Lubricate O-rings (22) and install over plugs (23) and tighten in place.

Lubricate O-rings (47) and install in underside of manifold block (15). Carefully place manifold block (15) on top of the valve cover (1) making sure the O-rings are correctly seated. Secure with four soc. hd. cap screws (41) by threading into valve block (1).

Install spring (16) and spool (38) into manifold (15) with the spring guide and spring towards the left side of the manifold (15) when viewing from the top rear.

Lubricate O-ring (22) and install on plug (14). Install plug in manifold (15) over spring (16).

Install orifice plug (61) in manifold (15). Install temporary plug (50) in 1/4" tube port.

Using a small hammer, carefully tap spring pins (46) into and through the retainer plate (42). The pins should bottom out in holes leaving enough length sticking out for piloting into the port block.

For valves with servo shutoff valve, place O-rings (56) on spool (24), lubricate and slide through body (15) until retainer grooves are exposed each end. Install retainers (55). Insert pin (57) through spool, align with horizontal hole and snap in position. Attach end of chain to screw (41) adjacent to pin.

Lubricate O-ring (47), (48) and (37) and install in the bottom of retainer plate (42).



## ASSEMBLY PROCEDURES

### PARTS LIST FOR FIGURE 13

valve block assembly for special  
mounting of servovalve (after 7-93)

item	description	part no.	qty.
1	valve block	033-91335	1
2	check valve assembly	S13-40266	2
3	orifice plug .047", 1,2 mm	033-91249	4
4	O-ring 90 S-1 ARP 903	691-00903	2
5	seat	033-70508	1
6	soc. setscrew 5/16-24 x 1	312-13160	1
7	hex nut 5/16-24	335-13100	1
8	housing	033-70545	1
9	O-ring 90 S-1 ARP 910	691-00910	1
10	seal piston	036-21767	1
11	O-ring 70 S-1 ARP 012	671-00012	1
12	spring	036-12289	1
13	cone	036-12288	1
14	servo strainer assembly	S13-43240	1
15	manifold, servovalve	033-54389	1
	manifold, servovalve with shutoff (7F, 7G controls)	033-54466	
16	spring (Lee LC-038C-19)	225-92083	1
19	O-ring 90 S-1 ARP 906	691-00906	3
20	hex plug SAE-6	488-35041	3
22	O-ring 90 S-1 ARP 904	691-00904	10
23	hollow hex plug SAE-4	488-35001	9
24	spool, servovalve shutoff (7F, 7G controls)	033-54445	1
25	plug (3HP5N-S)	488-35049	2
26	*spring pin 3/16 x 3/4	325-12120	2
27	sequence seat	033-70507	2
28	valve seat	033-70500	3
29	lower gasket	033-91193	1
30	sequence poppet	033-72378	2
31	valve poppet	033-72379	3
32	spring (light weight)	033-22141	1
33	spring (1 7/16" OAL)	033-70512	3
34	servo relief poppet	033-54398	1
35	spring (1" OAL)	033-71086	2
36	pilot relief assy	S23-12699	1
37	O-ring 70 S-1 ARP 050	671-00050	1
38	spool	033-54392	1
39	O-ring 90 S-1 ARP 008	691-00008	1
41	soc. hd. cap screw 10-24 x 1-1/4	358-10180	4
42	retainer plate	033-91422	1
43	button hd. screw 10-24 x 3/4	353-25078	4
44	servo relief seat	033-54399	1
45	acorn nut	327-25006	1
46	spring pin 1/8 x 3/4	325-08120	2
47	O-ring 70 S-1 ARP 013	671-00013	4
48	O-ring 70 S-1 ARP 014	671-00014	2
50	plug 7/16-20	449-00013	1
53	screw, soc. hd. 3/8-16 x 4	358-16360	4
54	plug	035-54400	1
55	retainer, spool (7F, 7G controls)	356-31043	2
56	O-ring, 90 S-1, ARP 011 (7F, 7G controls)	691-00011	2
57	pin (7F, 7G controls)	S23-02208	1
58	hex hd. screw	306-40132	4
61	orifice plug .047", 1,2 mm	033-25528	1

\*not used after 8-96

#### ASSEMBLY NUMBERS

**S23-12776**, without servovalve shutoff

**S23-12798**, with shutoff (7F, 7G controls)

**SEAL KIT S23-04226**



## ASSEMBLY PROCEDURES

### PARTS LIST FOR FIGURE 14

*assembly of shaft, shaft seal, output control stem, controls and valve block*

item	description	part no.	SAE mounting→		SAE shaft→			
			127-2	152-4	32-1	32-4	44-1	44-4
			qty	qty	qty	qty	qty	qty
1	no. 2 keyed shaft assy. (see fig. 1)	S13-41806	1					
	no. 3 splined shaft assy. (see fig. 1)	S13-41805		1				
	no. 4 keyed shaft assy. (see fig. 1)	S23-15832			1			
	no. 5 splined shaft assy. (see fig. 1)	S23-15831					1	
2	shim .008", 0,203 mm (use only 1)	033-53948	1	1				
	shim .007", 0,178 mm	033-53949						
3	retaining ring .066/.068", 1,68/1,73 mm	033-53901	1	1				
	retaining ring .070/.072", 1,78/1,83 mm	033-53902						
	retaining ring .074/.076", 1,88/1,93 mm	033-53903						
	retaining ring (D mounting)	356-65139			1	1		
4	shaft seal	623-00006	1	1				
	shaft seal	623-00016			1	1		
5	O-ring 70 S-1 ARP 043	671-00043	1	1				
	O-ring 70 S-1 ARP 249	671-00249			1	1		
6	seal retainer	033-57892	1	1				
	seal retainer	033-92286			1	1		
7	Nyltite® washer	631-45003	4	4				
	Nyltite® washer	631-45007			4	4		
8	screw, 1/4-20 x 1-3/4"	306-40144	4	4				
	screw, 3/8-16 x 1"	306-40016			4	4		
9	servo stem	033-71312	1	1	1	1		
10	balance plate	033-70546	1	1	1	1		
11	spacer	033-71247	2	2	2	2		
12	soc. hd. cap screw 10-24 x 2-3/4	358-10300	2	2	2	2		
13	Nyltite® washer	631-45007	8	8	8	8		
14	hex washer hd. screw 3/8-16 x 1-1/4	353-25018	8	8	8	8		
15	output control assembly	see S1-AM030	1	1	1	1		
16	input control assembly	see S1-AM030	1	1	1	1		
17	hex hd. cap screw 3/8-16 x 3-1/4	306-40184	8	8	8	8		
*18	gasket	033-91058	2	2	2	2		

\*Prior to 8-92, some controls use O-rings (18) 671-00017, (19) 671-00048 in lieu of gasket. Cast iron covers use gasket 033-91058.

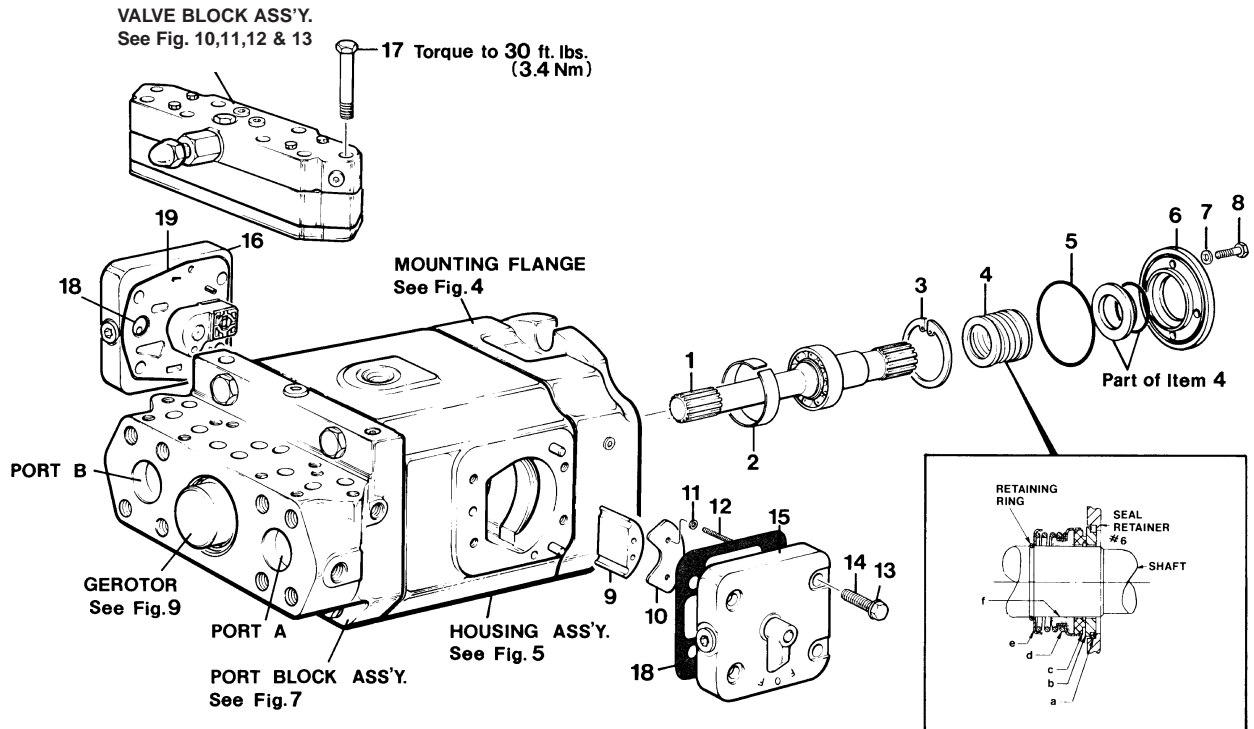

FIGURE 14

**SHAFT AND SEAL INSTALLATION**

See figure 14

Stand the pump in an upright position with the port block inlet and outlet pads turned down.

Install the shaft and bearing (1) assembly in the mounting flange and cradle. Be certain that there are no burrs or sharp edges on shaft seal area of the shaft.

For SAE 127-2 assembly, use the shim (2) that results in least clearance around the shaft bearing.

Install the snap ring (3) in the mounting flange to retain the shaft assembly. Be certain that the ring is fully seated in the groove. For SAE 127-2 assembly, use the ring that results in the tightest fit.

For SAE 127-2 assembly, remove the screws holding the cam/cradle assembly in position.

**Note:** See warning information next page. Before installing the seal assembly examine all the parts. The lapped seal seat and the carbon ring have a precision finish that must be handled with care. Be certain that both parts are free of scratches, marks and cracks.

**SEAL ASSEMBLY**

The seal assembly (4) is available as a complete unit only.

Place the spring retainer (e) over the shaft and against the retaining ring on the shaft assembly. Place the spring (d) against the retainer (e). Apply grease to the inner surface of the rubber friction ring (f) and position the shell containing the rubber friction ring (f) and carbon ring (c) over the shaft with the carbon ring exposed. Apply grease to the square section rubber seal (a) and install on the ceramic seat (b). Insert the seat and seal in the seal retainer (6) with the lapped side of the seat in position to contact the carbon ring. Place the seal retainer assembly and O-ring (5) over the shaft with the lapped surface against the carbon face. Place the four gaskets (7) on the four screws (8) and insert the seal retainer (6). Depress the seal retainer only far enough to start the four screws and tighten evenly. Torque to 10 ft. lb., 13,6 Nm (SAE 127-2), or to 30 ft.-lbs, 41 Nm (SAE 152-4).

**Note:** Seal installation must be completed quickly to avoid the rubber friction ring seizing on the shaft.

**MECHANICAL SHAFT SEAL  
ASSEMBLY PROCEDURE**

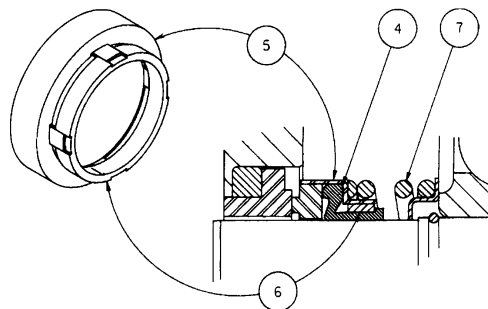

**Warning:** When installing a new mechanical shaft seal, exercise care to insure that all of the parts fit together properly. This is particularly important if the seal was once assembled and disassembled for some reason. If the rubber boot, item 4, grips the shaft and doesn't slide on the shaft as it is disassembled, then the spring, item 7, can disengage the shell, item 5, from the band, item 6, so that they do not re-engage properly when reassembled. Be sure the shell and the band are properly engaged before reassembling the seal, and stays engaged during assembly.

**Note:** Lubricate seal and shaft with clean hydraulic fluid of the same type that will be used in the system.

**COUNTERBALANCE SERVO  
STEM ASSEMBLY**

Place the two spacers (11) on the two screws (12) and insert through the balance plate (10) and servo stem (9).

Insert these parts through the opening in the side of the housing assembly and position the screws over the two 10-24 tapped holes in the rocker cam.

Hold these parts against the cam and alternately tighten the screws (12) to hold the assembly firmly in place. Torque screws to 5 ft. lb., 6,78 Nm

**CONTROL COVER INSTALLATION**

Place gasket (18) on control cover assembly. Note: some covers, prior to 8-92, (powdered metal covers) use O-rings 671-00017, 671-00048 instead of gasket 033-91058.

Install the cover assemblies (16 and 17) over the dowel pins on the housing pads and secure with seals (14) and screws (15). Torque to 30 ft. lb., 40,8 Nm.

**Note:** The input cover assembly must be installed on the right hand side of the housing on pumps with "B" suffix. Install the output cover assembly on the right hand side on models with "A" suffix.

**VALVE BLOCK INSTALLATION**

Apply petroleum jelly or grease to O-ring grooves on underside of valve block, figures 10 thru 13 as applicable. Insert O-rings in grooves. Place valve block on mating surface of port block, making certain that O-rings remain in place. Install screws (14) and uniformly torque to 30 ft. lb., 40,8 Nm.

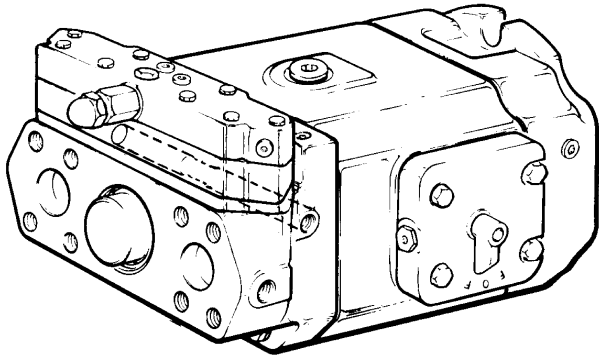

**WITHOUT FILTER  
NO PLUG**

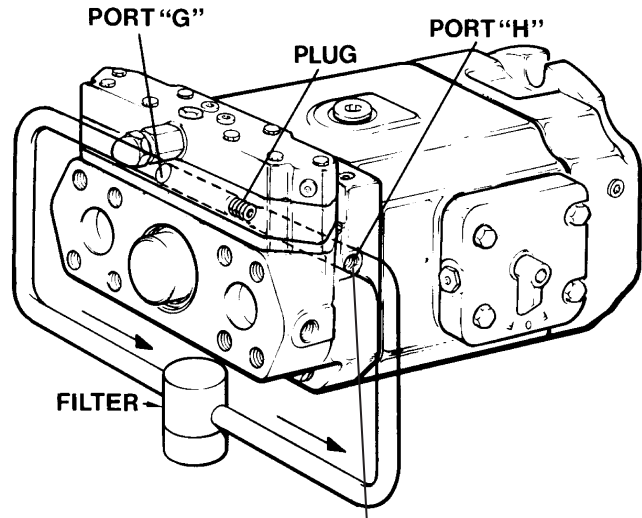

**EXTERNAL FILTER  
WITH PLUG**

Caution: See note on following page when installing GAGE.

**INSTRUCTIONS FOR REPLENISH-  
ING CIRCUIT ISOLATION PLUG**

**CAUTION:** The isolation plug included with pump is to be installed **ONLY** if an external filter circuit is provided. **DO NOT** operate unit with the isolation plug installed unless an external line has been provided.

When the external filter circuit **IS NOT** used discard the isolation plug.

When the external filter circuit **IS** used install the isolation plug between port G and H. Use a 3/16" hex. wrench by 4" minimum length **INSERTING THE ISOLATION PLUG INTO PORT H** and tighten to 80 - 120 in. lb. torque., 9,04 - 13,56 Nm

Isolation plug: part no. 311-45032 (3/8-16 x1/2 UNC flat point set screw)

GAGE LOCATIONS

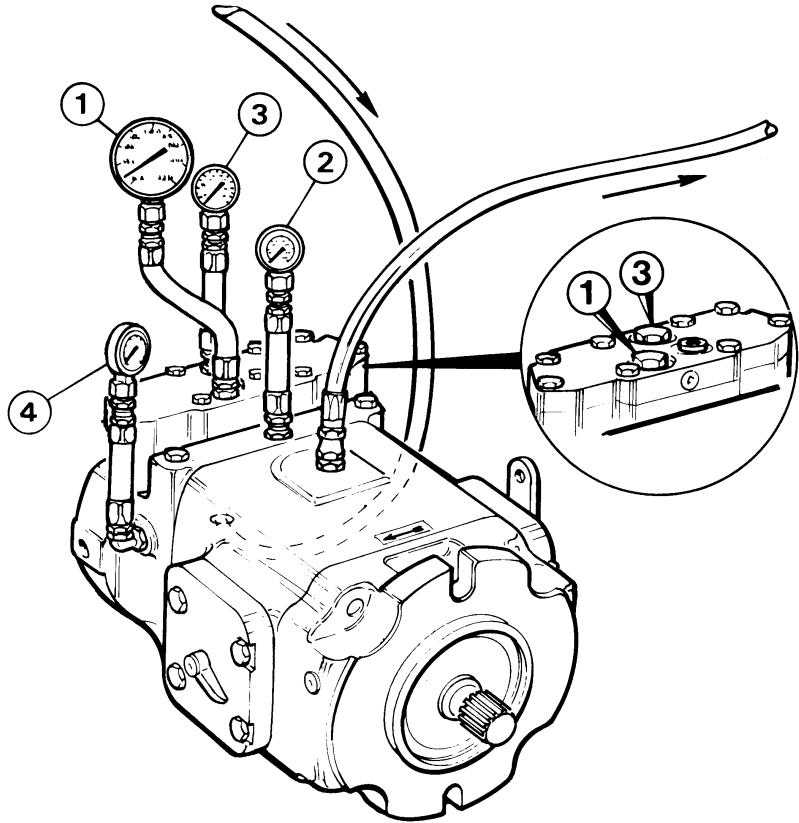

GAGE PRESSURE RANGES

1. 6000 PSI, 68,9 bar gage for A or B port
2. 200 PSI, 13,7 bar gage for case port
3. 500 PSI, 35 bar gage for replenishment port
4. 1000 PSI, 68,9 bar gage for servo port.

**Caution:** When installing system pressure gage (#1), make certain loose modulating pin is retained in the port

Note: Do not install gage in servo filter line when isolation plug is installed without "T" fitting. **FAILURE TO DO SO WILL RESULT IN AUXILIARY SHAFT FAILURE.**

TYPICAL PRESSURES

Closed Circuit	Open Circuit
Replenishment: 180-220 PSI, 12,4-15,1 bar+ case pressure	Replenishment: None
Servo: 300 PSI, 20,6 bar +case pressure + 40 PSI, 2,75 bar per 1000 PSI, 68,9 bar system pressure	Servo: 160 PSI, 11 bar + case pressure+ 62.5 psi, 4 bar per 1000PSI, 68,9 bar system pressure. (With 900 control, servo pressure is a constant 400-450 psi, 27,6-31 bar.)
Case: 75 PSI, 5,17 bar continuous 125 PSI, 8,62 bar intermittent	Case: 40 PSI, 2,75 bar maximum

**GENERAL REQUIREMENTS**

1. Maximum runout between pump shaft and electric motor shaft .003", 0,08 mm T.I.R. A floating shaft must have a support in mounting bracket. A fixed shaft should not have a support bearing in mounting bracket.
2. Electric motor speed - 1800 RPM.
3. Inlet temperature - 130° ± 10°F, 54° ± 4°C
4. Inlet condition
 

Main pump	100 to 150 PSI, 6,9 to 10,3 bar
Gerotor	10"Hg to 5 PSI, 254 mm Hg. to 0,34 bar
5. Case pressure 65 PSI ± 10 PSI, 4,5 ± 0,69 bar
6. Fluid - 200 SSU, 43cSt at 100° F, 37,8° C

**BASIC PUMP TEST**

*(closed circuit pumps, P\*P,P\*D)*

1. Mount pump on test stand. Connect system lines and auxiliary pump inlet line to pump. Connect case drain line to flowmeter.
2. With system pressure set at minimum, start electric motor. Observe servo and replenishing pressures. Shut off if pressures do not appear quickly.
3. Rotate pump input control shaft. The servo control should control pump displacement through its full range. Set pump displacement for full volume, and adjust system pressure for 1000 PSI, 69 bar. Check and record system flow and case drain flow above and below center.

	6.0 in <sup>3</sup>	7.25 in <sup>3</sup>	8.0 in <sup>3</sup>
<b>Maximum System Flow</b>	47 GPM 177,9 l/m	57 GPM 215,7 l/m	63 GPM 238 l/m
<b>Maximum Case Drain Flow</b>	1.5 GPM 5,7 l/m	1.8 GPM 6,8 l/m	1.86 GPM 7,04 l/m

4. Back out compensator adjusting screw until unit is fully compensated (count number of turns). Observe volume indicator and stroke rotary servo input shaft from full to full position on each side of center. Indicator should remain on or very near zero position. If compensator functions normally, return compensator adjusting screw to its original position and proceed with step 5.

**Caution:** Do not over-tighten adjusting screw.

5. Cycle pump at 10 sec. intervals - full volume above center to full volume below center as follows:

- |   |  |
|---|--|
| <p><b>6.0 IN<sup>3</sup> &amp; 7.25 in<sup>3</sup></b><br/>                 5 min. at 1000 PSI, 69 bar<br/>                 3 min. at 2500 PSI, 172 bar<br/>                 3 min. at 3500 PSI, 241 bar<br/>                 2 min. at 5000 PSI, 345 bar</p> | <p><b>8.0 in<sup>3</sup></b><br/>                 5 min. at 1000 PSI, 69 bar<br/>                 3 min. at 2500 PSI, 172 bar<br/>                 3 min. at 4500 PSI, 310 bar</p> |
|---|--|
- (Pumps with screw adjustment controls do not need to be cycled).

6. Adjust system pressure to 5000 PSI, 345 bar for 6.0 and 7.25 in<sup>3</sup>, or 4500 PSI, 310 bar for 8.0 in<sup>3</sup>. Set pump displacement at full volume. Check and record system flow and case drain flow above and below center.

	6.0 in <sup>3</sup>	7.25 in <sup>3</sup>	8.0 in <sup>3</sup>
<b>Minimum System Flow</b>	41 GPM 155,9 l/m	50 GPM 189 l/m	55 GPM 208 l/m
<b>Maximum Case Drain Flow</b>	3.0 GPM 11,4 l/m	3.6 GPM 13,6 l/m	3.6 GPM 13,6 l/m

7. Set pump to compensate at 5000 PSI, 345 bar for 6.0 and 7.25 in<sup>3</sup>, or 4500 PSI, 310 bar for 8.0 in<sup>3</sup>. Servo pressure should be at least 500 PSI, 34,5 bar for 6.0 and 7.25 in<sup>3</sup>, or 469 PSI, 32,3 bar for 8.0 in<sup>3</sup>. (For pumps with 900 control, 400 to 450 PSI, 27,6 to 31 bar.) Check and record case leakage flow (Replenishing flow).

**Minimum flow**     6.5 GPM, 24,6 l/m.

8. Set pump to compensate at minimum PSI. Check and record replenishing and servo pressure.

**BASIC PUMP TEST***(continued)***Servo pressure-Minus Case Pressure** 308 to 420 PSI, 21,2 to 29 bar.*(For pumps with 900 control, 400 to 450 PSI, 27,6 to 31 bar.)***Repl. Pressure-Minus Case Pressure-** 200 PSI  $\pm$  20 PSI, 13,8  $\pm$  1,4 bar

If pressures are incorrect, remove replenishing relief valve pilot and increase or decrease pressure as required. (One full turn on adj. screw will cause pressure to change approximately 25 PSI, 1,7 bar). Re-torque locknut to 20-25 in/lb., 2,3-2,8 Nm.

**Note:** There is no servo relief valve adjustment. Increasing or decreasing repl. pressure will cause both servo and repl. pressure to change by the same amount.

9. Set pump to compensate at 5000 PSI, 345 bar. for 6.0 and 7.25 in<sup>3</sup>, or 4500 PSI, 310 bar for 8.0 in<sup>3</sup>. Record repl. and servo pressure.

**Servo pressure-minus case pressure** 508 to 620 PSI, 35 to 42,8 bar for 6.0 and 7.25 in<sup>3</sup>, or 448 to 560 PSI, 31 to 39 bar for 8.0 in<sup>3</sup> *(For pumps with 900 control, 400 to 450 PSI, 27,6 to 31 bar.)*

**Repl. Pressure-minus case pressure** 200 PSI  $\pm$  20 PSI, 13,8  $\pm$  1,4 bar

10. Set pump to compensate at minimum PSI. Servo pressure should return to 308 to 420 PSI, 21,2 to 29 bar. *(For pumps with 900 control, 400 to 450 PSI, 27,6 to 31 bar.)*

**Repl. Pressure-Minus Case Pressure-** 200 PSI  $\pm$  20 PSI, 13,8  $\pm$  1,4 bar

**Note:** After completing above test, proceed with pump control test and adjustment per controls manual. Continue pump test after testing control.

11. Adjust pump displacement for full volume and adjust system pressure to 6000 PSI, 414 bar for 6.0 and 7.25 in<sup>3</sup>, or 4500 PSI, 310 bar for 8.0 in<sup>3</sup>. Adjust compensator from maximum to minimum pressure. At each pressure, stroke rotary servo input shaft to the full position on each side of center. Indicator should remain on or very near the zero position with no oscillation. System pressure should not vary from port "A" to port "B" more than 150 PSI, 10,3 bar and not oscillate. Minimum compensator pressure should be under 500 PSI, 34,5 bar.

**Caution:** Do not hold pump at these pressures for longer than one minute at any time. This is only an intermittent pressure rating.

12. Set pump to compensate at 1000 PSI, 69 bar UNLESS OTHERWISE SPECIFIED. Increase and decrease system pressure above and below compensator setting. When system pressure is above compensator setting, the pump should de-stroke and not oscillate. When the system pressure is below the compensator setting, the pump should stroke to full volume.

13. Check pump for external leaks. No external leaks permitted.

**GENERAL REQUIREMENTS**

1. Maximum runout between pump shaft and electric motor shaft .003", 0,08 mm T.I.R. A floating shaft must have a support in mounting bracket. A fixed shaft should not have a support bearing in mounting bracket.
2. Electric motor speed - 1800 RPM.
3. Inlet temperature - 130° ± 10°F, 54° ± 4°C
4. Inlet condition
 

Main pump	50 to 75 PSI, 3,4 to 5,2 bar
Gerotor	10"Hg to 5 PSI, 254 mm Hg. to 0,34 bar
5. Case pressure 65 PSI ± 10 PSI, 4,5 ± .69 bar
6. Fluid - 200 SSU, 43cSt at 100° F, 37,8° C

**BASIC PUMP TEST**  
(open circuit pumps, P\*V)

1. Mount pump on test stand. Connect system lines and auxiliary pump inlet line to pump. Connect case drain line to flowmeter. Connect an external relief to servo port "G" or "H".
2. With system pressure set at minimum, start electric motor. Observe servo pressure. Shut off if pressures do not appear quickly.

Note: set input control stop to stroke pump one side of center only. In all cases, "A" shall be inlet and "B" shall be outlet.

pump rotation	input "A" mounting	input "B" mounting
CW	CW rotation	CCW rotation
CCW	CCW rotation	CW rotation

3. Rotate pump input control shaft. The servo control should control pump displacement through its full range. Set pump displacement for full volume, adjust external servo relief to 180 psi, 12,4 bar. (For units with 900 control, 350 psi, 24 bar). Check and record system flow and case drain flow

	6.0 in <sup>3</sup>	7.25 in <sup>3</sup>	8.0 in <sup>3</sup>
<b>Maximum System Flow</b>	47 GPM 177,9 l/m	57 GPM 215,7 l/m	63 GPM 238 l/m
<b>Maximum Case Drain Flow</b>	1.5 GPM 5,7 l/m	2.0 GPM 7,6 l/m	2.3 GPM 8,7 l/m

4. Raise system pressure to 1000 PSI, 69 bar. Back out compensator adjusting screw until unit is fully compensated (count number of turns). Observe volume indicator and stroke rotary servo input shaft from full to zero to full position. Indicator should remain on or very near zero position. If compensator functions normally, return compensator adjusting screw to its original position and proceed with step 5.

<b>Caution:</b> Do not over-tighten adjusting screw.
--

5. Raise external servo relief setting above pump servo setting. Cycle pump at 10 sec. intervals - full to zero volume as follows:

<p><b>6.0 IN<sup>3</sup> &amp; 7.25 in<sup>3</sup></b></p> <p>5 min. at 1000 PSI, 69 bar                  3 min. at 2500 PSI, 172 bar                  3 min. at 3500 PSI, 241 bar                  2 min. at 5000 PSI, 345 bar</p>	<p><b>8.0 in<sup>3</sup></b></p> <p>5 min. at 1000 PSI, 69 bar                  3 min. at 2500 PSI, 172 bar                  3 min. at 4500 PSI, 310 bar</p>
---	--

(Pumps with screw adjustment controls do not need to be cycled).

6. Adjust system pressure to 5000 PSI, 345 bar for 6.0 and 7.25 in<sup>3</sup>, or 4500 PSI, 310 bar for 8.0 in<sup>3</sup>. Set pump displacement at full volume. Set external servo relief to 350 PSI, 24 bar. Check and record system flow and case drain flow.

	6.0 in <sup>3</sup>	7.25 in <sup>3</sup>	8.0 in <sup>3</sup>
<b>Minimum System Flow</b>	40 GPM 155,9 l/m	48.5 GPM 189 l/m	55 GPM 208 l/m
<b>Maximum Case Drain Flow</b>	4.0 GPM 15 l/m	4.8 GPM 18 l/m	4.8 GPM 18 l/m



**BASIC PUMP TEST**

*(continued)*

7. Set pump to compensate at 5000 PSI 345 bar for 6.0 and 7.25 in<sup>3</sup>, or 4500 PSI, 310 bar for 8.0 in<sup>3</sup>. Raise external servo relief to above pump servo setting. Servo pressure minus case pressure should be 450 to 550 PSI, 31 to 38 bar. (For pumps with 900 control, 400 to 450 PSI, 27,6 to 31 bar). Check and record case leakage flow (Replenishing flow).

**Minimum flow** 6.0 GPM, 22,7 l/m.

8. Set pump to compensate at 1000 PSI, 69 bar. Check and record servo pressure.

**Servo pressure-minus case pressure** 200 to 250 PSI, 13,8 to 17,2 bar. (For pumps with 900 control, 400 to 450 PSI, 27,6 to 31 bar).

**Note:** After completing above test, proceed with pump control test and adjustment per controls manual. Continue pump test after testing control.

9. Adjust pump displacement for full volume and adjust system pressure to 6000 PSI, 414 bar\* for 6.0 and 7.25 in<sup>3</sup>, or 4500 PSI, 310 bar for 8.0 in<sup>3</sup>. Adjust compensator from maximum to minimum pressure. At each pressure, stroke rotary servo input shaft from full to minimum position. Indicator should remain on or very near the zero position with no oscillation. Minimum compensator pressure should be under 500 PSI, 34,5 bar.

**\*Caution:** Do not hold pump at these pressures for longer than one minute at any time. This is only an intermittent pressure rating.

12. Set pump to compensate at 1000 PSI, 69 bar UNLESS OTHERWISE SPECIFIED. Increase and decrease system pressure above and below compensator setting. When system pressure is above compensator setting, the pump should de-stroke and not oscillate. When the system pressure is below the compensator setting, the pump should stroke to full volume.

13. Check pump for external leaks. No external leaks permitted.

PUMP INSTALLATION DRAWING

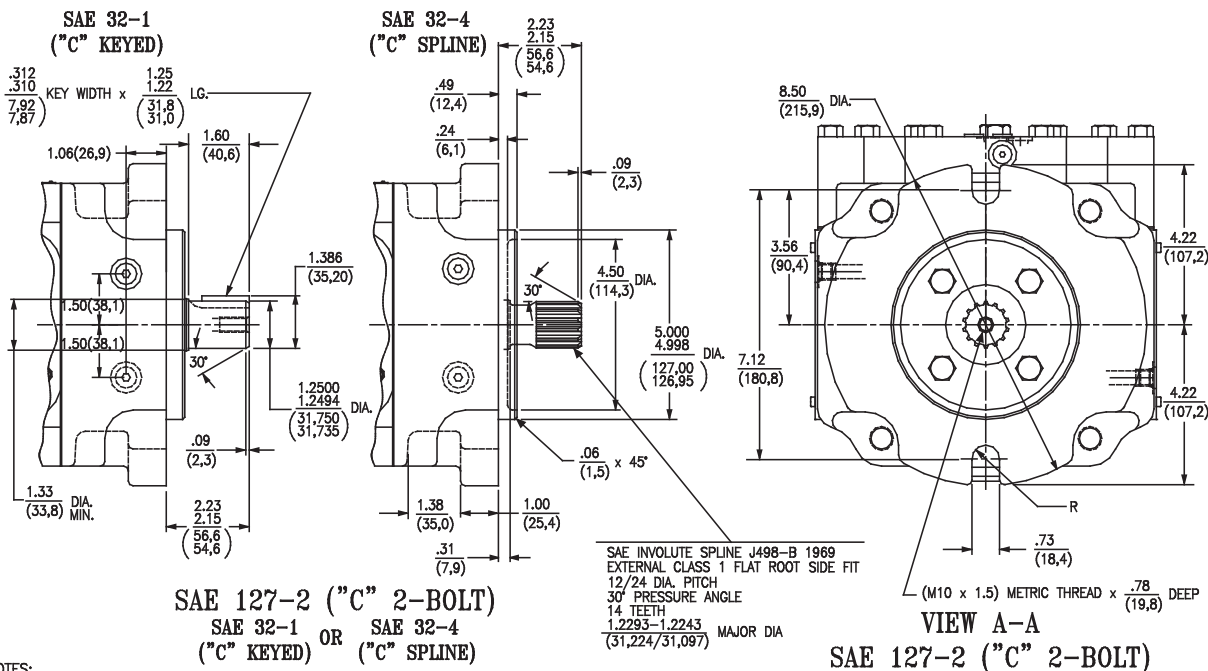
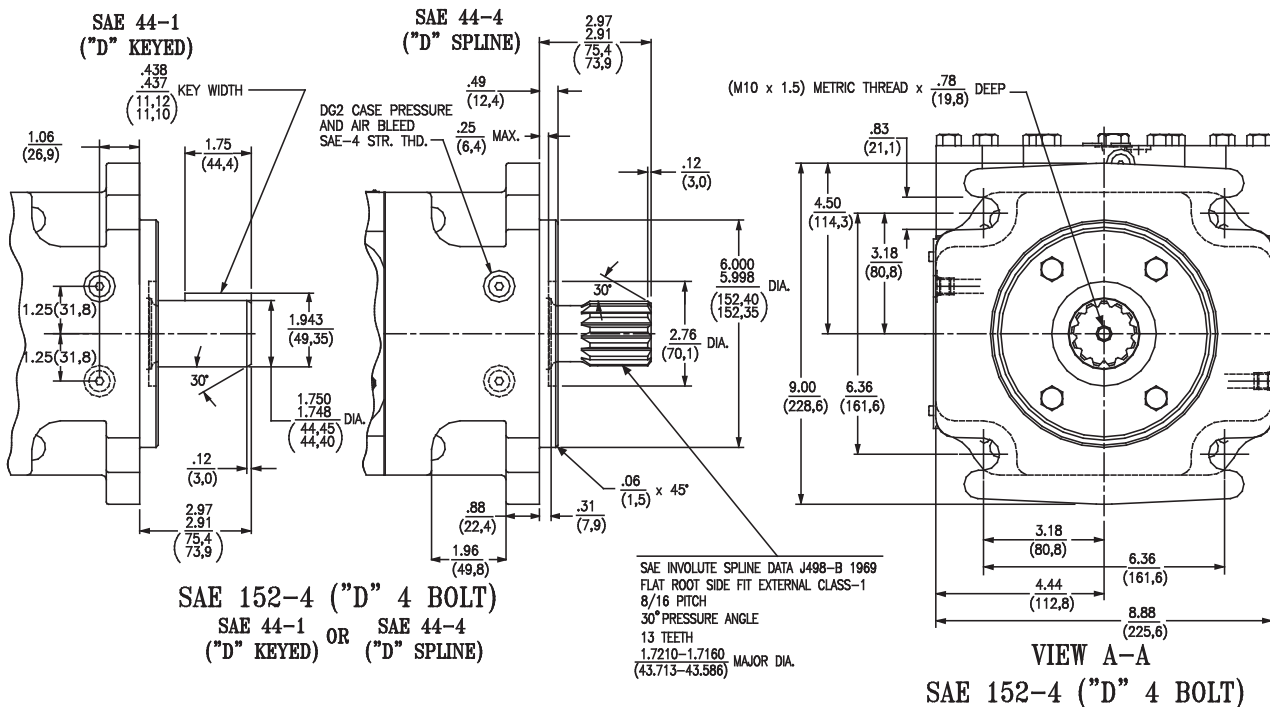

NOTES:

1. REFERENCE TO PUMP ROTATION, R-CW & L-CW, IS AS VIEWED FROM SHAFT END.
2. DIMENSIONS IN PARENTHESIS ARE METRIC (SI UNITS).
3. CAUTION - REPLENISHING PUMP ISOLATION PLUG SHALL BE INSTALLED ONLY WHEN EXTERNAL FILTER IS PROVIDED FROM PORT "G" TO PORT "H". SEE INSTRUCTIONS PROVIDED IN ISOLATION KIT.
4. FOR INPUT & OUTPUT CONTROLS SEE APPROPRIATE INSTALLATION DRAWINGS.

# PUMP INSTALLATION DRAWING

MOUNTING	L1	L2	L3	L4	L5	L6	L7	L8	L9
SAE 127-2 (SAE-C)	15.06 (382,5)	13.70 (348,0)	12.76 (324,2)	10.64 (270,3)	7.02 (178,3)	10.58 (268,8)	15.51 (393,9)	12.92 (328,2)	3.80 (96,5)
SAE 152-4 (SAE-D)	16.40 (416,6)	15.04 (382,1)	14.10 (358,2)	11.98 (304,3)	8.36 (212,3)	11.92 (302,8)	16.85 (427,9)	14.26 (362,3)	5.14 (130,5)

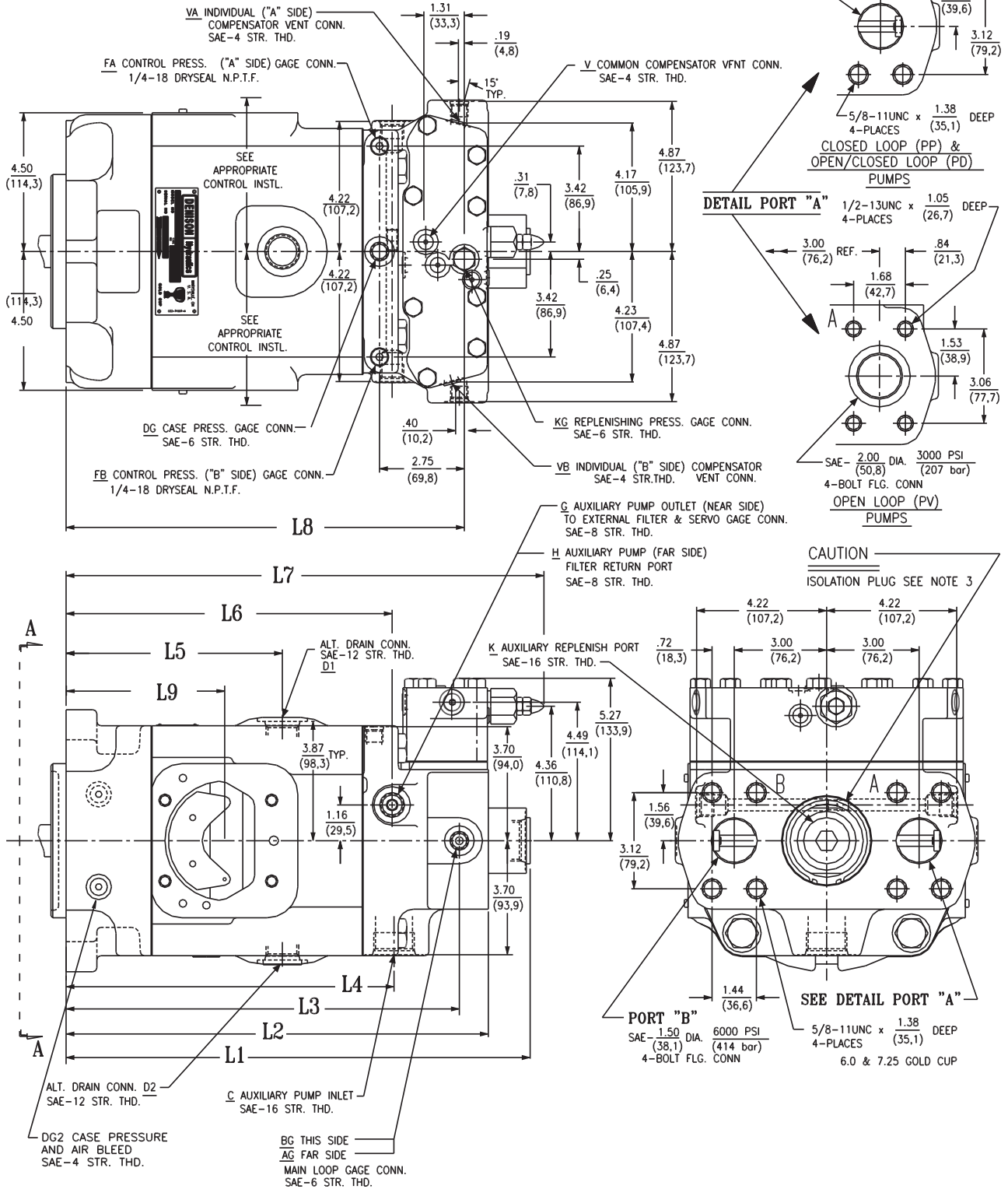

## CONVERSIONS & FORMULAS

### DEFINITION & UNIT

<i>displacement</i>	$\text{in}^3/\text{rev} \times 16,387 = \text{cm}^3/\text{rev}$	$\text{cm}^3/\text{rev} \times 0,06102 = \text{in}^3/\text{rev}$
<i>flow</i>	$\text{gpm} \times 3,78 = \text{l/min}$	$\text{l/min} \times 0,2642 = \text{gpm}$
<i>power</i>	$\text{hp} \times 0,7457 = \text{kW}$	$\text{kW} \times 1,341 = \text{hp}$
<i>torque</i>	$\text{lb-ft} \times 1,3567 = \text{Nm}$	$\text{Nm} \times 0,7376 = \text{lb-ft}$
<i>pressure</i>	$\text{lbs/in}^2 \text{ (psi)} \times 0,06895 = \text{bar}$ $\text{lbs/in}^2 \text{ (psi)} \times 6,895 = \text{kPa}$	$\text{bar} \times 14,50 = \text{lbs/in}^2 \text{ (psi)}$ $\text{kPa} \times 0,1450 = \text{lbs/in}^2 \text{ (psi)}$
<i>weight</i>	$\text{lb} \times 0,4536 = \text{kg}$	$\text{kg} \times 2,205 = \text{lbs}$
<i>force</i>	$\text{lb} \times 4,448 = \text{N}$	$\text{N} \times 0,2248 = \text{lbs}$
<i>volume</i>	$\text{in}^3 \times 16,387 = \text{cm}^3$	$\text{cm}^3 \times 0,06102 = \text{in}^3$
<i>area</i>	$\text{in}^2 \times 6,452 = \text{cm}^2$	$\text{cm}^2 \times 0,1550 = \text{in}^2$
<i>length</i>	$\text{in} \times 25,4 = \text{mm}$	$\text{mm} \times 0,03937 = \text{in}$
<i>temperature</i>	$\text{degree F}-32 = \text{°C}$ 1,8	$1,8 \times \text{°C}+32 = \text{°F}$
<i>viscosity</i>	$\text{cSt} \times 1,0 = \text{mm}^2/\text{sec}$ $(\text{SSU}-14) \approx \text{cSt}$ 4,25	$\text{mm}^2/\text{sec} \times 1,0 = \text{cSt}$ $\text{cSt} \times 4,25 + 14 \approx \text{SSU}$

### FLUID POWER FORMULAS

<i>Pump input torque</i>	<i>lbs. in.</i>	$\frac{\text{pressure(psi)} \times \text{displacement (in}^3/\text{rev)}}{2\pi \times \text{mech. eff.}}$
<i>Pump input power</i>	<i>hp</i>	$\frac{\text{rpm} \times (\text{in}^3/\text{rev}) \times (\text{psi})}{395934 \times \text{overall eff.}}$
<i>Pump output flow</i>	<i>U.S. gpm</i>	$\frac{\text{rpm} \times (\text{in}^3/\text{rev}) \times \text{volumetric eff.}}{231}$
<i>Fluid motor speed</i>	<i>rpm</i>	$\frac{231 \times \text{flow rate(U.S. gpm)} \times \text{volumetric eff.}}{\text{displacement (in}^3/\text{rev)}}$
<i>Fluid motor torque</i>	<i>lbs. in.</i>	$\frac{\text{pressure(psi)} \times \text{displacement (in}^3/\text{rev)} \times \text{mech. eff.}}{2\pi}$
<i>Fluid motor power</i>	<i>hp</i>	$\frac{\text{rpm} \times (\text{in}^3/\text{rev}) \times (\text{psi}) \times \text{overall eff.}}{395934}$
<b>(metric)</b>		
<i>Pump input torque</i>	<i>Nm</i>	$\frac{\text{pressure(bar)} \times \text{displacement (cm}^3/\text{rev)}}{20\pi \times \text{mech. eff.}}$
<i>Pump input power</i>	<i>kW</i>	$\frac{\text{rpm} \times (\text{cm}^3/\text{rev}) \times (\text{bar})}{600000 \times \text{overall eff.}}$
<i>Pump output flow</i>	<i>Lpm</i>	$\frac{\text{rpm} \times (\text{cm}^3/\text{rev}) \times \text{volumetric eff.}}{1000}$
<i>Fluid motor speed</i>	<i>rpm(min<sup>-1</sup>) (tr/mn)</i>	$\frac{1000 \times \text{flow rate (Lpm)} \times \text{volumetric eff.}}{\text{displacement (cm}^3/\text{rev)}}$
<i>Fluid motor torque</i>	<i>Nm</i>	$\frac{\text{pressure(bar)} \times \text{displacement (cm}^3/\text{rev)} \times \text{mech. eff.}}{20\pi}$
<i>Fluid motor power</i>	<i>kW</i>	$\frac{\text{rpm} \times (\text{cm}^3/\text{rev}) \times (\text{bar}) \times \text{overall eff.}}{600000}$

"The product information specifications and descriptions contained in this catalog have been compiled for the use and convenience of our customers from information furnished by the manufacturer, and we cannot and do not accept any responsibility for the accuracy or correctness of any description, calculation, specification or information contained herein. No such description, calculated, specified or information regarding the products being sold has been made part of the basis of the bargain nor has same created or amounted to an express warranty that the products would conform thereto. **We are selling the goods and merchandise illustrated and described in this catalog on an as is basis and disclaim any implied warranty, including any warranty of merchantability or warranty of fitness for any particular purposes whatsoever, with respect to the goods and merchandise sold.** All manufacturer warranties shall be passed on to our customers, but we shall not be responsible for special, indirect, incidental or consequential damages resulting from the use of any of the products or information contained or described in the catalog."

# PUMP KEY SHEET

**P 6 P -2 R 1 C -4 A 2 -A -00 -0 B 1 -M-XXXXX**

**Pump series**

**Displacements, Max.**

- 6 - 6.0 in<sup>3</sup>/rev., 98 cc/rev.
- 7 - 7.25 in<sup>3</sup>/rev., 119 cc/rev.
- 8 - 8.0 in<sup>3</sup>/rev., 131 cc/rev.

- P - closed circuit
- D - open-closed circuit
- V - open circuit unit

**Flange/shaft**

- 2- SAE 127-2 w/SAE 32-1 shaft (keyed C)
- 3- SAE 127-2 w/SAE 32-4 shaft (splined C)
- 4- SAE 152-4 w/SAE 44-1 shaft (keyed D)
- 5- SAE 152-4 w/SAE 44-4 shaft (splined D)

**Shaft rotation**

- (viewed from shaft end)  
 R - CW, L - CCW

**Fluid class**

- 1 - compatible w/Buna N
- 4 - compatible w/EPR
- 5 - compatible w/Viton

**Design letter**

(assigned by manufacturer)

**Primary controls**

- 1 - screw adjustment
- 2 - cylinder control
- 4 - rotary servo (spring centered w/trimmer)
- 5 - electrohydraulic stroker
- 6 - hydraulic stroker
- 7 - servovalve & feedback device  
(all include rotary servo, pressure compensator  
override & displ. indicator)
- 8 - proportional hydraulic stroker
- 9 - electrohydraulic stroker

**Primary controls, options**

- 0 - none
- A - adjustable maximum volume stops
- B - automatic brake control
- C - A & B above, together
- D - 10 GPM servovalve w/feedback potentiometer
- E - 10 GPM servovalve w/feedback RVDT
- F - 10 GPM servovalve w/potentiometer & 4A2 control
- G - 10 GPM servovalve w/2/RVDT & 4A2 control
- H - 3 pos. (spring centered w/trimmer)
- M - 2A/2 position, electric w/4D01 & adj. max. vol. stop
- N - 2A/3 position, electric w/4D01 spring centered

**Secondary controls**

- 2 - auxiliary replenishment port
- 4 - torque limiter and auxiliary replenishing port

**Control location**

- A - command on port A side
- B - command on port B side  
(displacement indicator on opposite side)

**Designates special**

**External mounting**

- 0 - pump not mounted
- 1 - pump mounted (must be separately specified)

**External drive**

- 0 - none
- A - SAE-82-2 (A)
- B - SAE-101-2 (B)

**Internal pump**

**P6, P7 & P8**

- 0 - 1.07 in<sup>3</sup>/rev., 17.5 cc/rev.
- X - no internal pump (std. on tandem pumps)

**Control features**

- 2M\* & 2N\***
- 00-110 VAC/60Hz Hirschmann
- 01-12 VDC, Hirschmann connector
- 02-240 VAC/50Hz Hirschmann connector
- 03-110 VAC/60Hz wiring box
- 04-12 VDC, wiring box
- 05-less directional valve

**500 control**

- 00 - with deadband
- 01 - without deadband
- 02 - N/A

**600 control**

- 00 - 75-350 psi, 5-24 bar
- 01 - 75-435 psi, 5-30 bar
- 02 - 100-380 psi, 7-26 bar
- 03 - 150-400 psi, 10,3-27,6 bar

**700 control**

- 00 - w/o manual shut-off
- 01 - w manual shut-off
- 02 - N/A

**800 control**

- 00 - 75-350 psi, 5-24 bar
- 01 - 75-435 psi, 5-30 bar
- 02 - 100-380 psi, 7-26 bar
- 03 - 150-400 psi, 10,3-27,6 bar
- 04 - 75-250 psi, 5-17 bar

**900 control**

- 00 - 24 VDC
- 01 - 12 VDC
- for all other controls use 00**

- allowable controls: P-P:** 102, 104, 2A2, 2A4, 2H2, 2H4, 2M2, 2M4, 2N2, 2N4, 402 404, 4A2, 4A4, 4B2, 4B4, 4C2,
- P-D:** 5A2, 5A4, 5C2, 5C4, 602, 604, 6B2, 6B4, 7D2, 7E2, 7F2, 7G2,8A2, 8A4, 9A2, 9A4

- allowable controls: P-V:** 102, 104, 2A2, 2A4, 2M2, 2M4, 4A2, 4A4, 4C2, 4C4, 5A2, 5A4, 5C2, 5C4, 6A2, 6A4, 6C2, 6C4, 7D2, 7E2, 7F2, 7G2, 8A2, 8A4, 9A2, 9A4

Fluid class	Pump	SEAL KITS valve block	hi-ig valve block	SAE 127-2 shaft seal kit	SAE 127-2 shaft seal	SAE 152-4 shaft seal
1- compatible with Buna N	S23-00134-0	S23-00135-0	S23-04226-0	S23-44302-0	623-00006-0	623-00016-0
4 - compatible with EPR	S23-00134-4	S23-00135-4	S23-04226-4	S23-44302-4	623-00006-4	623-00016-4
5 - compatible with Viton	S23-00134-5	S23-00135-5	S23-04226-5	S23-44302-5	623-00006-5	623-00016-5

500 controls are useable with petroleum based fluids only

900 controls are useable with fluids compatible with Viton. S-4 version is available as M Mod.







**International Distributors****In Europe:**

Cyprus  
 Eastern Europe  
 The Faroe Islands  
 Finland  
 Greece  
 Iceland  
 Norway  
 Portugal  
 Switzerland  
 Turkey

**In Africa:**

Algeria  
 Egypt  
 Ivory Coast  
 Morocco  
 Nigeria  
 South Africa  
 Togo  
 Tunisia

**In Middle East:**

Iran  
 Israel  
 Lebanon  
 Pakistan  
 Qatar  
 Saudi Arabia  
 Syria  
 United Arab Emirates

**In Far East:**

Indonesia  
 Korea  
 Malaysia  
 New Zealand  
 Philippines  
 Thailand

**Australia**

DENISON HYDRAULICS Pty. Ltd.  
 41-43 St. Hillers Road  
 P.O. Box 192  
 Auburn, N.S.W. 2144  
 Tel. (612) 9646 5200  
 Fax (612) 9643 1305  
**Other sales offices:**  
 Queensland  
 South Wantirna Victoria  
 Western Australia

**Austria**

DENISON HYDRAULIK GmbH  
 Zweigniederlassung Linz  
 Haidbachstraße 69  
 A-4061 Pasching  
 Tel. (43) 7229 4887  
 Fax (43) 7229 63092

**Benelux**

DENISON HYDRAULICS  
 BENELUX B. V.  
 Pascalstraat 100  
 3316 Dordrecht  
 Holland  
 Tel. (31) 786179 900  
 Fax (31) 786175 755

**Canada**

DENISON HYDRAULICS  
 CANADA Inc.  
 2320 Bristol Circle, Unit 1  
 Oakville, ON L6H 5S2  
 Tel. (905) 829 5800  
 Fax (905) 829 5805  
**Other sales offices:**  
 Montreal, QC  
 Calgary, AB

**China, P.R.**

DENISON HYDRAULICS Ltd.  
 3F, No. 1, Mao Jia Zhai, Bai Lian Jing  
 Pudong New Area  
 Shanghai 200126,  
 Tel. (86) 21 5886 8991  
 Fax (86) 21 5886 1978

**Denmark**

DENISON HYDRAULIK  
 DENMARK A/S  
 Industriekrogen 2  
 DK-2635 Ishøj  
 Tel. (45) 4371 15 00  
 Fax (45) 4371 15 16

**Finland**

DENISON HYDRAULICS  
 P.O. Box 36  
 FIN-08101 Lohja  
 Tel. (358) 208 33 045  
 Fax (358) 207 33 045

**France**

DENISON HYDRAULICS  
 FRANCE SA  
 14, route du Bois Blanc  
 BP 539  
 18105 Vierzon  
 Tel. (33) 2 48 53 01 20  
 Fax (33) 2 48 75 02 91  
**Other sales offices:**  
 Bordeaux  
 Lyon  
 Paris

**Germany**

DENISON HYDRAULIK GmbH  
 Herderstrasse 26  
 D-40721 Hilden  
 Tel. (49) 2103 940-6  
 Fax (49) 2103 940-880  
**Other sales offices:**  
 Dresden  
 Hanover  
 Stuttgart

**Great Britain**

DENISON HYDRAULICS U.K.  
 Ltd.  
 Kenmore Road  
 Wakefield 41, Industrial Estate  
 Wakefield, WF20XE  
 West Yorkshire  
 England  
 Tel. (44) 19 24 826 021  
 Fax (44) 19 24 826 146  
**Other sales offices:**  
 Burgess Hill

**Hong Kong, N. T.**

DENISON HYDRAULICS Ltd.  
 Unit 3, 25/F Wharf Cable Tower  
 9 Hoi Shing Road  
 Tsuen Wan  
 Tel. (852) 24988381  
 Fax (852) 24991522

**Italy**

DENISON HYDRAULICS S.r.l.  
 Viale Europa 68  
 20090 Cusago (MI)  
 Tel. (39) 2 90 33 01  
 Fax (39) 2 90 39 06 94

**Japan**

DENISON JAPAN Inc.  
 4-2-1 Tsujido-Shinmachi  
 Fujisawa 251,  
 Tel. (81) 466 35 3257  
 Fax (81) 466 35 2029  
**Other sales office:**  
 Osaka

**Mexico, Central America, South America and Caribbean Countries Contact**

DENISON HYDRAULICS Inc.  
 6167 NW 181 Terrace Circle North  
 Miami, FL 33015, USA  
 Tel. (305) 362 2246  
 Fax (305) 362 6220

**Other European, Middle East and African Countries Contact**

DENISON HYDRAULICS  
 FRANCE SA  
 14, route du Bois Blanc  
 BP 539  
 18105 Vierzon Cedex  
 France  
 Tel. (33) 2 48 53 01 45  
 Fax (33) 2 48 53 01 46

**Singapore**

DENISON HYDRAULICS S.E.A.  
 Pte. Ltd.  
 No. 11 Lorong Tukang Dua  
 2261 Singapore  
 Tel. (65) 2687840  
 Fax (65) 2687847

**Spain**

DENISON HYDRAULICS, S.A.  
 Gomis, 1  
 08023 Barcelona  
 Tel. (34) 3418 46 87  
 Fax (34) 3211 65 07  
**Other sales offices:**  
 San Sebastian

**Sweden**

DENISON HYDRAULICS  
 SVENSKA AB  
 Sporregatan 13  
 213 77 - Malmö  
 Tel. (46) 40 21 04 40  
 Fax (46) 40 21 47 26  
**Other sales offices:**  
 Spånga

**Taiwan, R.O.C.**

DENISON HYDRAULICS Ltd.  
 6F-10, No. 79, Sec. 2, Roosevelt Road  
 Taipei,  
 Tel. (886) 2 3645101 / 3645102  
 Fax (886) 2 3639025

**USA**

DENISON HYDRAULICS Inc.  
 14249 Industrial Parkway  
 Marysville, OH 43040  
 Tel. 937 644 3915  
 Fax 937 642 3738  
 For nearest Distributor:  
 Call toll free 1 800 551 5956  
**Other sales offices:**  
 Fulton, CA  
 Mulberry, FL  
 Moline, IL  
 Rock Island, IL  
 Kentwood, MI  
 Portland, OR  
 Collierville, TN  
 Arlington, TX  
 Houston, TX

Your local DENISON representative

**DENISON** Hydraulics