

DENISON HYDRAULICS
Premier series
open circuit pumps P16 & 260 C-mod.
service information

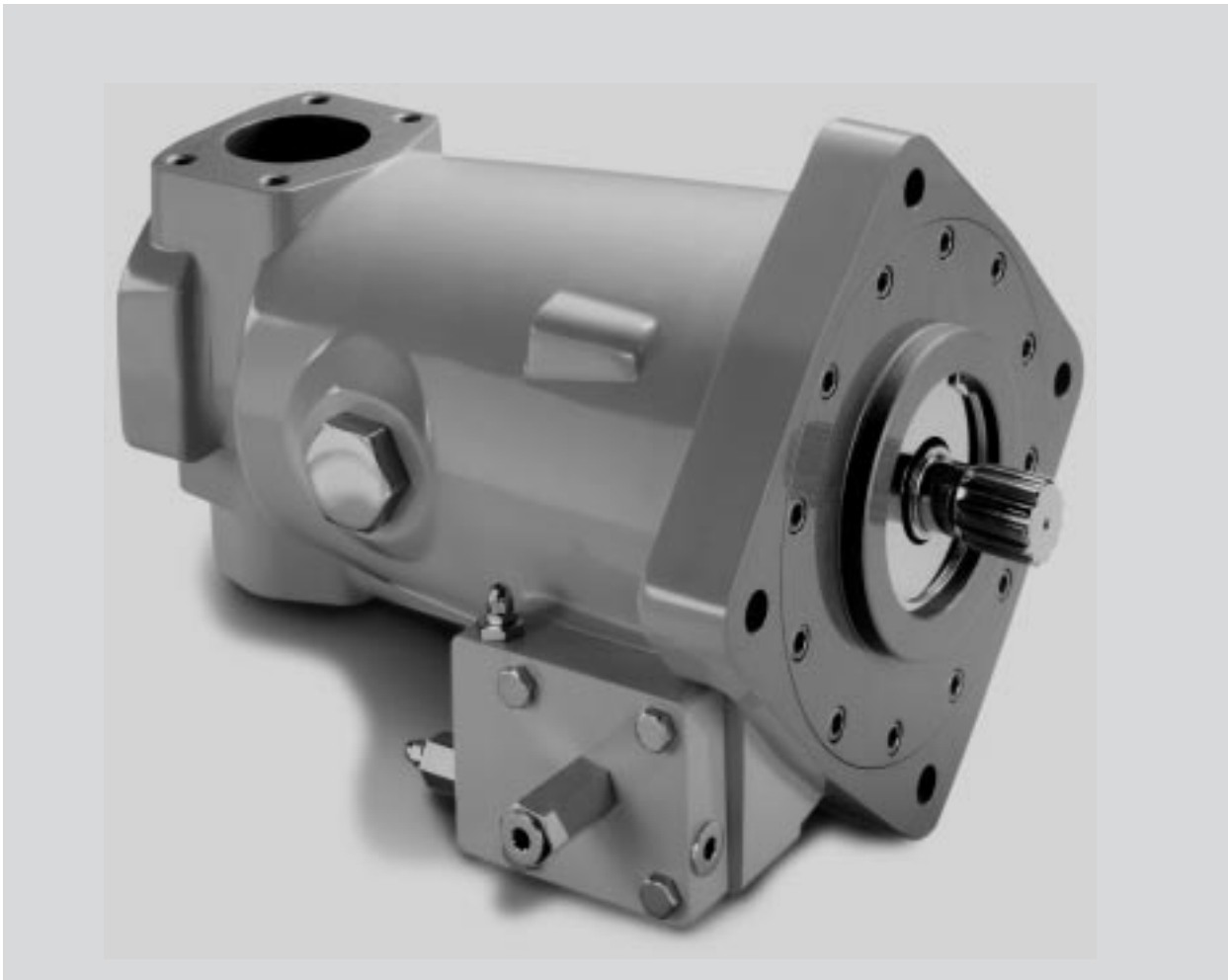

Publ. S1-AM022-B replaces S1-AM022-A, S1-AM021-A, S1-AM024-A, S1-AM026-A

Revised 3/03

DENISON | **Hydraulics**

TITLE	PAGE
Port Identification	3
Start up Procedure	7
Trouble shooting charts	8
Disassembly	10
Rework limits	11
Parts list	12
Rear drive adaptors	16
Conversion	17
Reassembly	18
Controls	25
Testing	64
Tools	77
Characteristics	79
Ordering code	83

Seal kit	P16	S22-12830-0
.....	P16 with "X" CONTROL	S22-16220
.....	P260 ISO	S22-12831-0
.....	P260 DIN	S22-16160-0
.....	P260 with "X" CONTROL	S22-16221

The shaft seal and all "O" rings necessary for total seal replacement may be obtained by ordering Seal Kit . These seals are suitable for petroleum base fluids. For fire resistant fluids contact **DENISON HYDRAULICS**, Inc. or their authorized distributors to obtain the appropriate seal kit number.

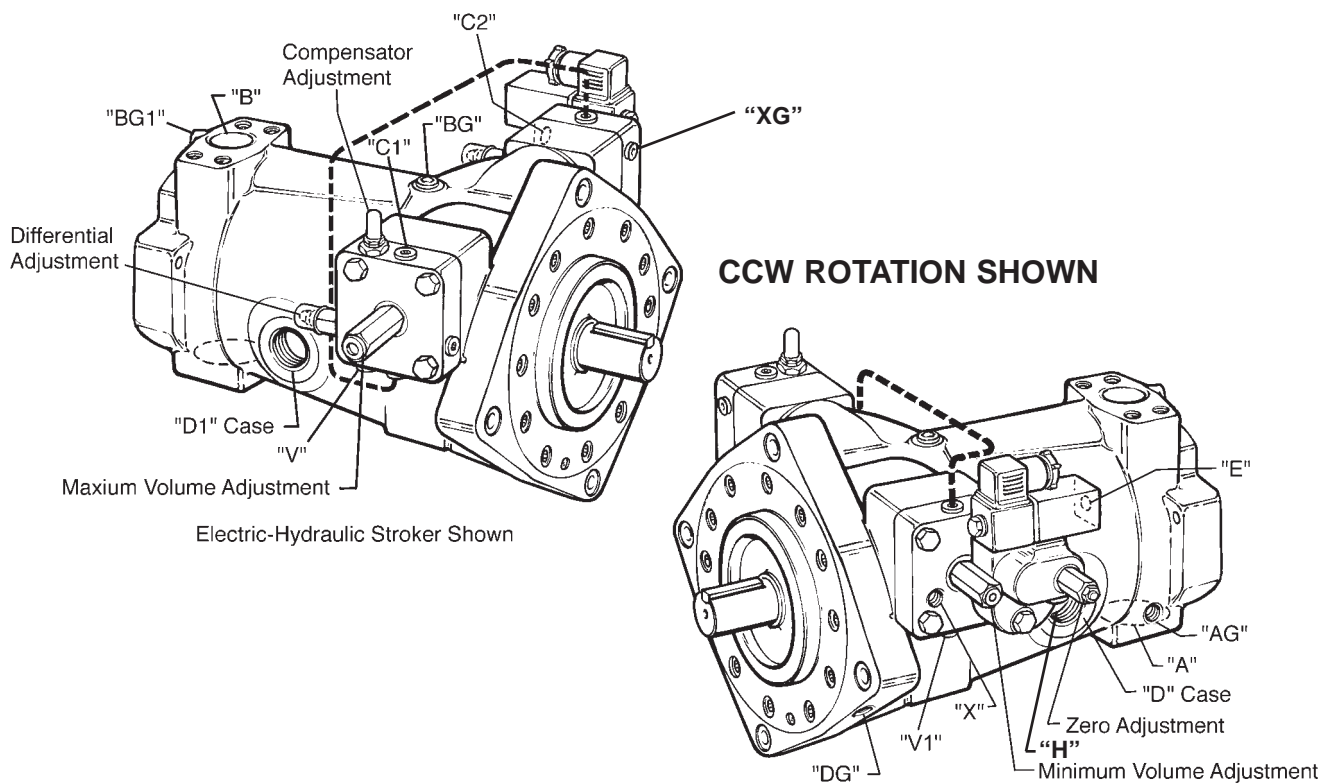

Electric-Hydraulic Stoker Shown

FLUID CONNECTIONS

DESCRIPTION	P16 C MOD	P260 C MOD
PORT AINLET	3-1/2 SAE CODE 61 5/8-11 SCREWS	3-1/2 SAE CODE 61 M16-2 SCREWS
PORT BSYSTEM	1-1/2 SAE CODE 62 5/8-11 SCREWS	1-1/2 SAE CODE 62 M16-2 SCREWS
PORT C1OFF-STROKE CYL. GAGE.....	SAE-4	1/4 BSPP
PORT C2ON-STROKE CYL. GAGE	SAE-4	1/4 BSPP
PORT DCASE DRAIN	SAE-24	1-1/2 BSPP
PORT D1CASE DRAIN	SAE-24	1-1/2 BSPP
PORT DG.....DRAIN GAGE, AIR BLEED PORT	SAE-4	1/4 BSPP
PORT AG.....INLET GAGE	SAE-4	1/4 BSPP
PORT BG.....SYSTEM GAGE.....	SAE-4	1/4 BSPP
PORT BG1....ALT. SYS. GAGE.....	SAE-6	1/4 BSPP
PORT EELECTROHYDRAULIC STROKER SERVO SUPPLY	SAE-4	1/4 BSPP
PORT HHYDRAULIC STROKER SIGNAL	SAE-4	1/4 BSPP
PORT LSLOAD SENSING LINE	SAE-4	1/4 BSPP
PORT VCOMPENSATOR, TORQUE LIMITER, LOAD SENSING VENT	SAE-8	3/8 BSPP
PORT VOVERRIDE COMP, OVERRIDE TORQUE LIMITER VENT	SAE-4	1/4 BSPP
PORT V1SERVO VENT	SAE-4	1/4 BSPP
PORT XSERVO SUPPLY	SAE-8	3/8 BSPP
PORT XGSERVO GAGE	SAE-10	1/2 BSPP

CW ROTATION

TORQUE LIMITER WITH ADJ. MAX. VOL. STOP, CCW and

TORQUE LIMITER WITH HANDWHEEL ADJ. MAX. VOL. STOP, CCW

LOAD SENSING WITH ADJ. MAX. VOL. SCREW STOP, CCW

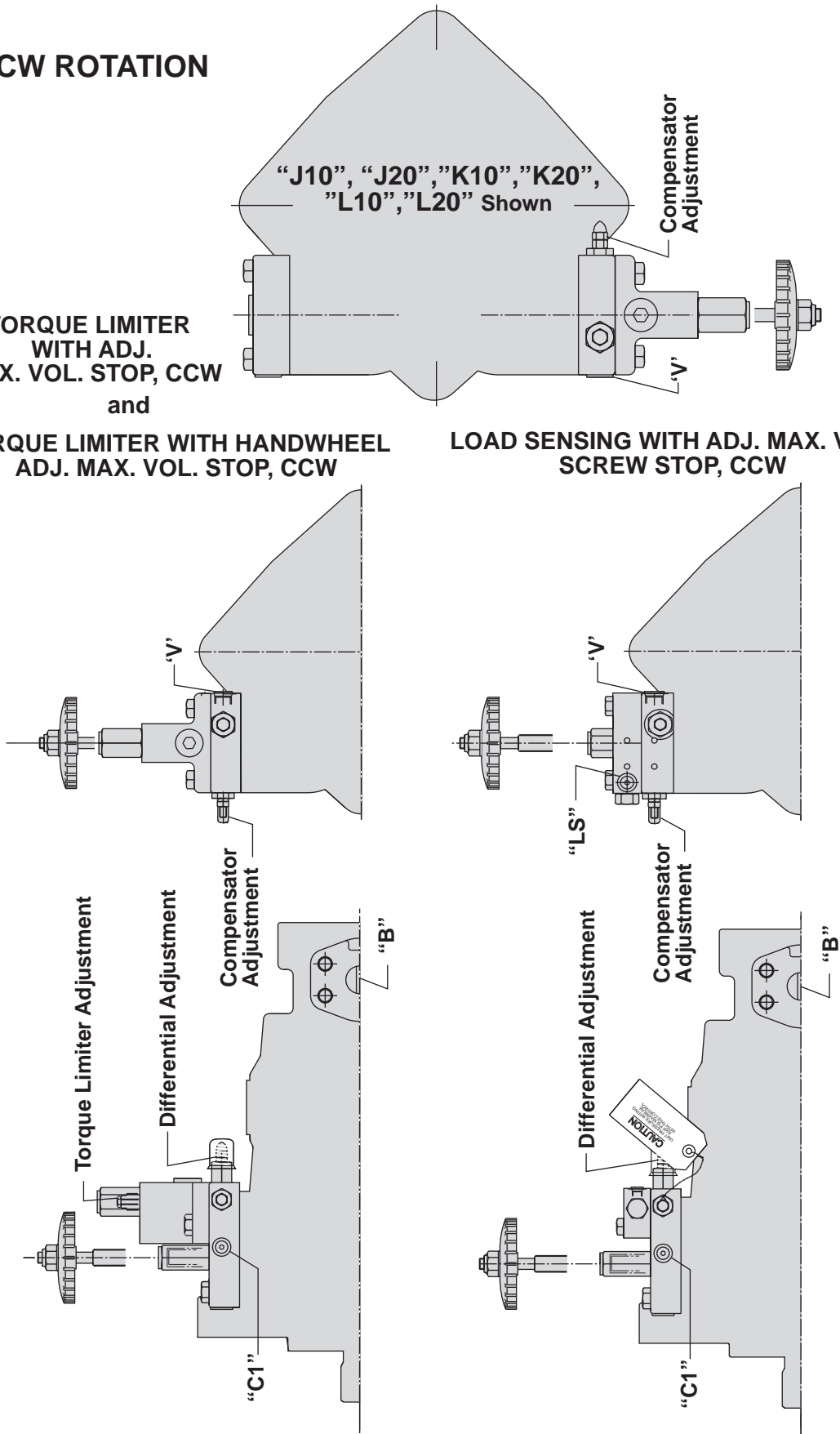

CW ROTATION

“R” ROTARY SERVO

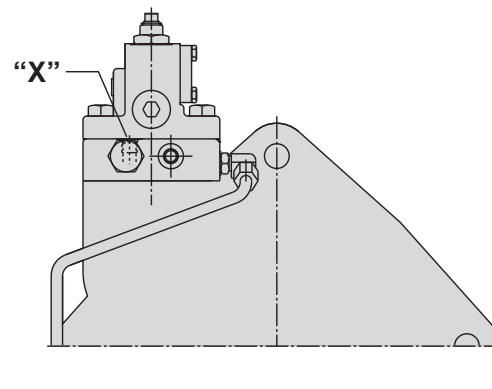

“E” ELECTRO-HYDRAULIC STROKER

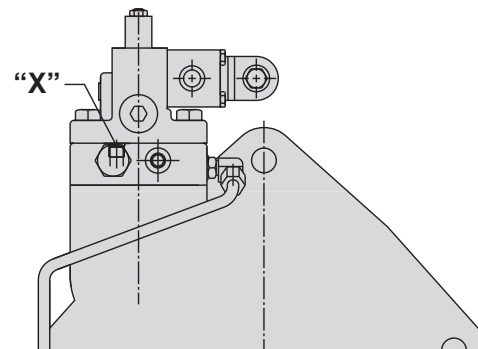

“H” HYDRAULIC STROKER

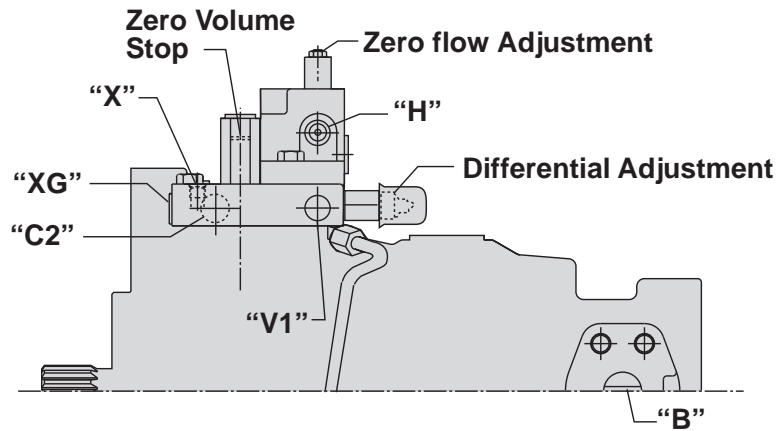
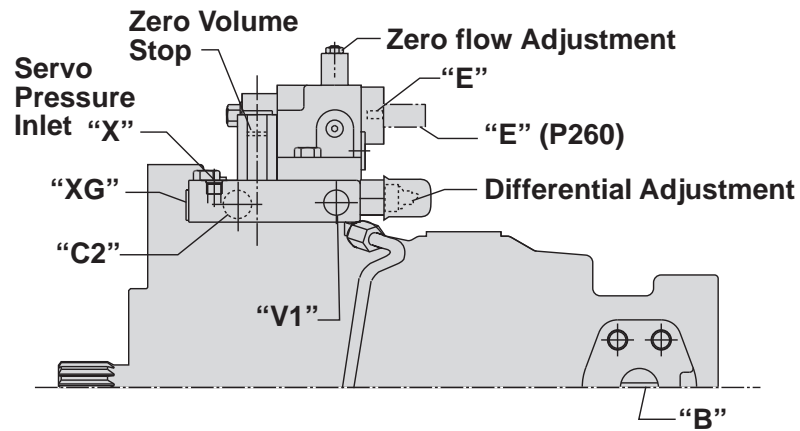
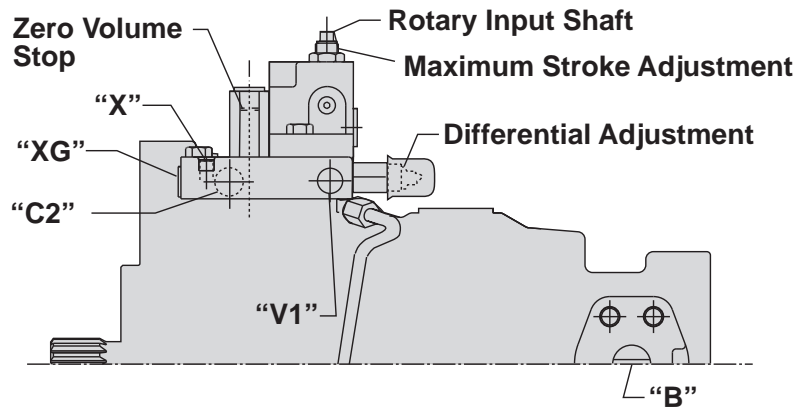
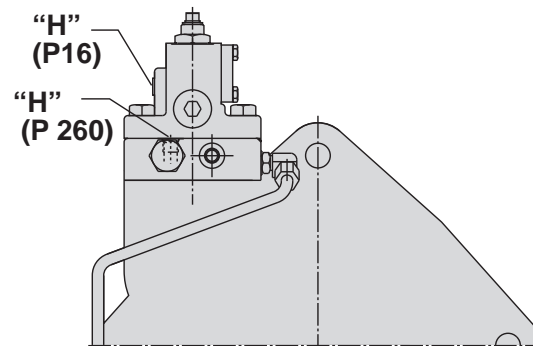

**“*1J” TORQUE LIMITER
OVERRIDE W/MAX. VOLUME STOP
or**

**“*1K” TORQUE LIMITER
OVERRIDE W/MAX. VOLUME STOP**

**“*1P” COMPENSATOR
OVERRIDE W/MAX.
VOLUME STOP**

**“*10” CONTROL CAP
WITH MAX. VOLUME
STOP**

CW ROTATION

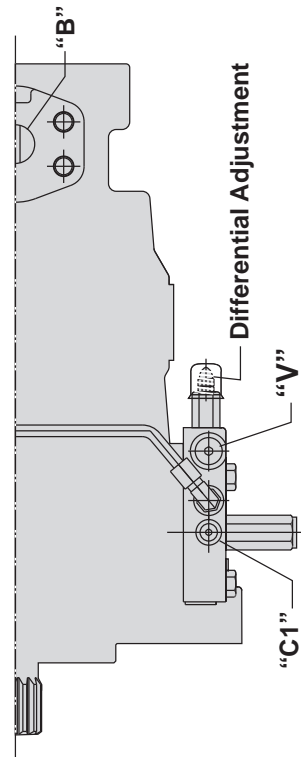
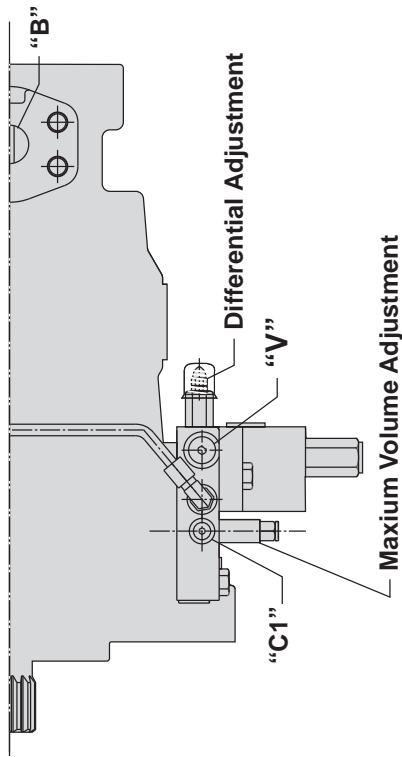
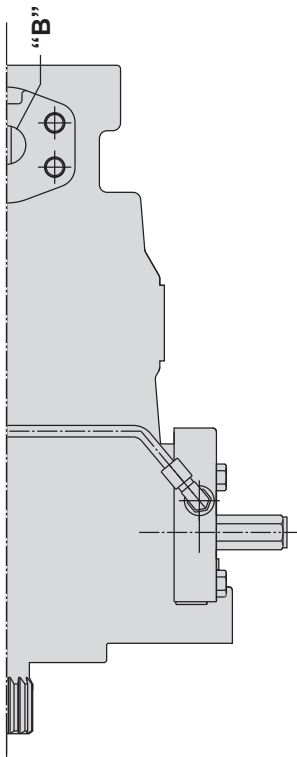
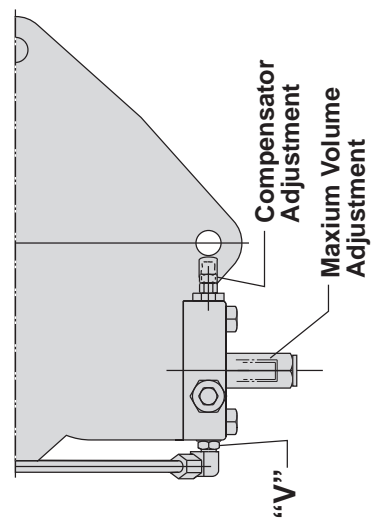
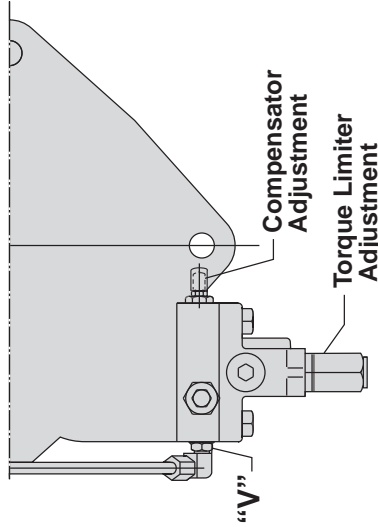
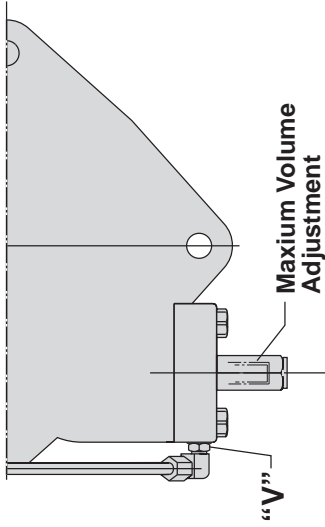

START UP PROCEDURE FOR NEW INSTALLATION

- Read and understand the instruction manual. Identify components and their function.
- Visually inspect components and lines for possible damage.
- Check reservoir for cleanliness. Drain and clean as required
- Check fluid level and fill as required with filtered fluid at least as clean as that recommended. Fill pump case with clean oil prior to starting. If pump is mounted vertically with shaft up, bleed air from case by removing plug from port "DG" till fluid runs clear.
- Check alignment of drive.
- Check oil cooler and activate it, if included in circuit. Check fluid temperature
- Reduce pressure settings of compensator and relief valve. Make sure accurate pressure readings can be made at appropriate places.
- If solenoids are in system, check for actuation.
- Start pump drive. Observe for correct shaft rotation. Make sure pump fills properly.
- Bleed system of air. Recheck fluid level.
- Cycle unloaded machine at low pressure and observe actuation (at low speed, if possible).
- Increase pressure settings gradually in steps. Check for leaks in all lines, especially in pump and motor inlet lines.
- Make correct pressure adjustments.
- Gradually increase speed. Be alert for trouble as indicated by changes in sounds, system shocks and air in fluid.
- Equipment is operational.

TROUBLESHOOTING

Component problems and circuit problems are often interrelated. An improper circuit may operate with apparent success but will cause failure of a particular component within it. The component failure is the effect, not the cause of the problem. This general guide is offered to help in locating and eliminating the cause of problems by studying their effects.

Effect of Trouble	Possible Cause	Fault Which Needs Remedy
pump noisy	air in system	leak in suction line. low fluid level. turbulent fluid. return lines above fluid level. gas leak from accumulator. excessive pressure drop in the inlet line from a pressurized reservoir. suction line strainer acting as air trap.
	cavitation in rotating group.	fluid too cold, too viscous, or too heavy. shaft speed too high. suction line strainer too small, or strainer too dirty. operating altitude too high. boost pressure too low. inlet flow too small for dynamic conditions.
	misaligned shaft.	faulty installation. distortion in mounting. axial interference. faulty coupling. excessive overhung loads.
	mechanical fault in pump.	piston and shoe looseness or failure. bearing failure. incorrect port plate selection or index. eroded or worn parts in the displacement control.
erosion on barrel ports and port plate.	air in fluid. cavitation.	see noisy pump above. see noisy pump above.
high wear in pump.	excessive loads.	reduce pressure settings. reduce speeds.
	contaminant particles in fluid.	improper filter maintenance. filters too coarse. introduction of dirty fluid to system. reservoir openings. improper reservoir breather. improper line replacement.
	Improper fluid.	fluid too thin or thick for operating temperature range. breakdown of fluid with time/temperature/shearing effects. incorrect additives in new fluid. destruction of additive effectiveness with chemical aging
	improper repair.	incorrect parts, procedures, dimensions, finishes.
	unwanted water in fluid.	condensation. faulty breather/strainer. heat exchanger leakage. faulty clean-up practice. water in makeup fluid.
pressure shocks.	cogging load.	mechanical considerations.
	worn relief valve.	needed repairs.
	worn compensator.	needed repairs.
	slow response in check valves.	replace or relocate.
	excessive decompression energy rates.	improve decompression control.
	excessive line capacitance. (line volume, line stretch, accumulator effects).	reduce line size or lengths. eliminate hose.
heating of fluid.	barrel blow-off.	re-check pump holddown, rotating group, drain pressure.
	excessive pump leakage.	recheck case drain flow and repair as required. fluid too thin. improper assembly, port timing.
	relief valve.	set too low (compared to load or to compensator). instability caused by back pressure, worn parts.
	compensator.	set too high (compared to relief). worn parts.
	pump too large for fluid needs.	select smaller pump displacement.
	heat exchanger.	water turned off, too hot or too little flow. fan clogged or restricted. efficiency reduced by mud or scale deposits. intermittent hydraulic fluid flow.
	reservoir.	too little fluid. improper baffles. insulating air blanket that prevents heat rejection. heat pickup from adjacent equipment.

TROUBLESHOOTING

Effect of Trouble	Possible Cause	Fault Which Needs Remedy
Compensator, Compensator Override Low system pressure	Compensator malfunction	Dirt in spool orifice Damaged cone or seat Broken differential spring Improperly adjusted differential spring
Failure to compensate	Differential adjustment	Differential set too high
Sluggish response	Differential adjustment	Differential set too low
Wide pressure fluctuations (hunting)	Excessive line capacitance	Install check valve near pump outlet
Load Sensing Control Low system pressure	Compensator malfunction	Dirt in spool orifice Damaged cone or seat Broken differential spring Improperly adjusted differential spring
Failure to compensate	Differential adjustment	Differential set too high
Sluggish response	Differential adjustment Modulating valve	Differential set too low Air in load sensing line
Wide pressure fluctuations (hunting)	Excessive line capacitance Modulating valve	Install check valve near pump outlet Air in load sensing line
Excessive pressure drop across control valve	Differential adjustment	Differential set too high
Poor control of flow	Differential adjustment	Differential set too low
Torque Limiter, Torque Limiter Override Torque setting erratic	Torque limiter cap malfunction	Sticking pin
Torque incorrect at high flows	Incorrect torque setting	Outer adjustment screw
Torque incorrect at low flows	Incorrect torque setting	Inner adjustment screw
Too much torque variation	Wrong torque limiter for range	Replace inner/outer springs with correct springs
Low system pressure	Compensator malfunction	Dirt in spool orifice Damaged cone or seat Broken differential spring Improperly adjusted differential spring
Failure to compensate	Differential adjustment	Differential set too high
Sluggish response	Differential adjustment	Differential set too low
Wide pressure fluctuations (hunting)	Excessive line capacitance	Install check valve near pump outlet
Rotary Servo Failure to stroke	Differential adjustment	Differential set too low
Goes to full	Differential adjustment	Differential set too high
Sluggish response	Low servo pressure	Check servo pressure
Strokes in steps	Servo cap malfunction	Sticking pin Wear on linkages or input cam surface
Hydraulic Stroker Failure to stroke	Differential adjustment	Differential set too low
Goes to full	Differential adjustment	Differential set too high
Strokes in steps	Servo cap malfunction	Wear on linkages, Sticking stroker piston
Electric Stroker Failure to stroke	Differential adjustment	Differential set too low
Goes to full	Differential adjustment	Differential set too high
Excessive hysteresis	Electric proportional valve	Change dither on electrical signal
No response	Electric proportional valve	Faulty wiring, Filter screen plugged
Strokes in steps	Servo cap malfunction	Wear on linkages Sticking stroker piston
Instability	Air in control	Bleed air from control Check for air in servo supply

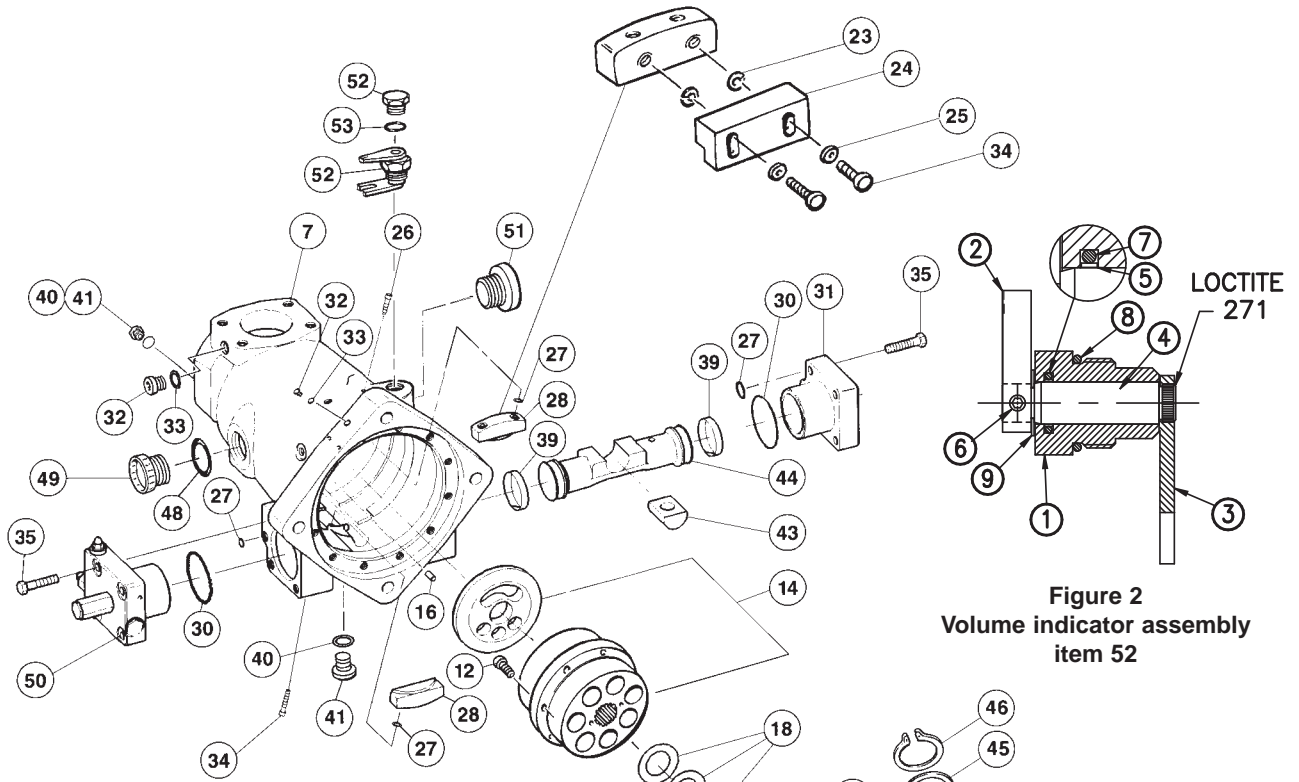

Figure 2
Volume indicator assembly
item 52

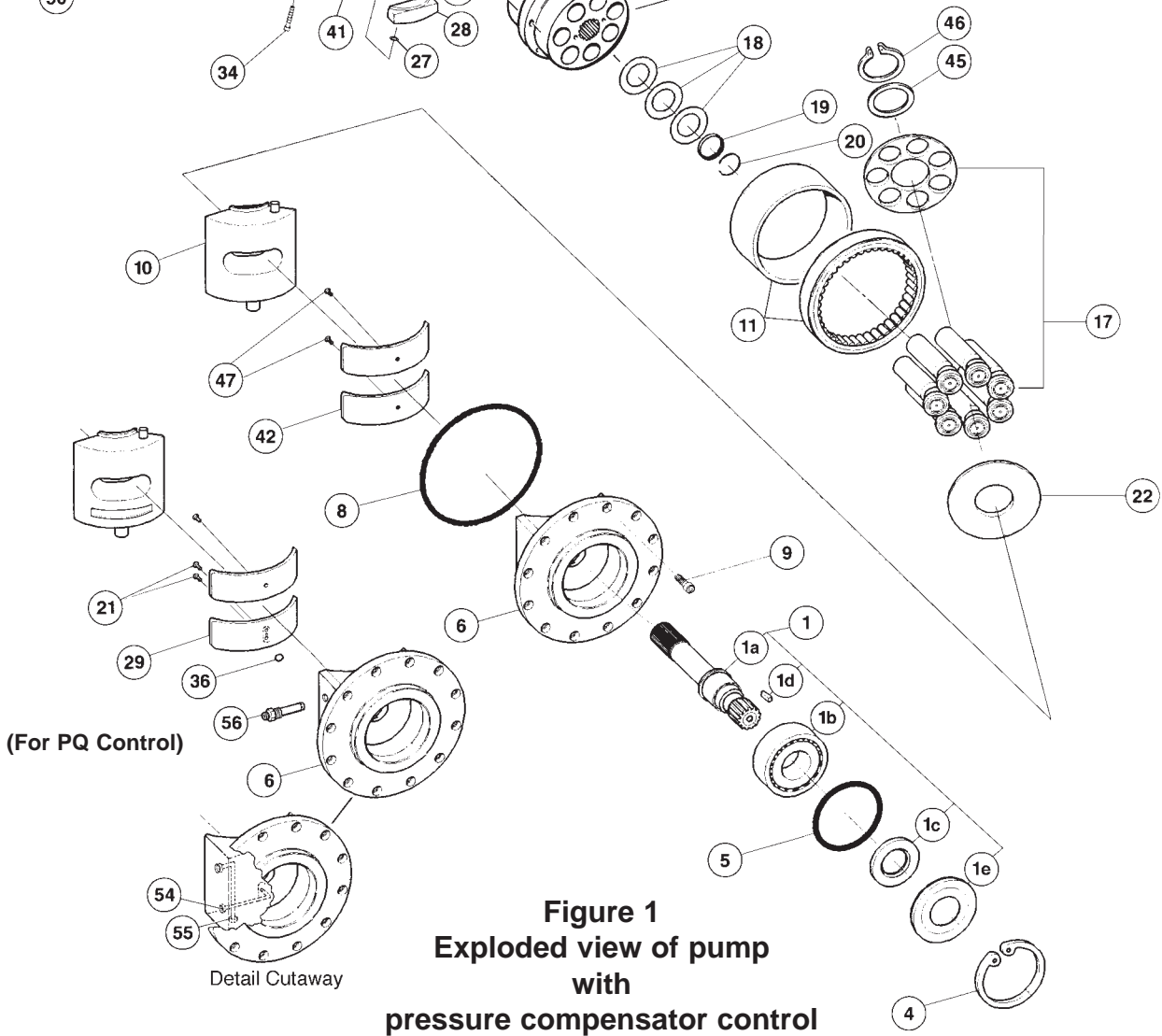

Figure 1
Exploded view of pump
with
pressure compensator control

Disassembly

Disassemble only as far as necessary to replace or repair worn parts.

If the pump has a rear drive, the mounting adapter and coupling must be removed prior to pump disassembly *Refer to figure 3 page 16.*

Clean outside surface of the pump before disassembly. Disassembly area should be clean. A suitable surface should be used capable of supporting the pump weight of 325 lbs., 147.5 Kg.

Refer to illustration, see figure 1 and 2

1. Remove plug (49) and drain oil from pump. Position pump with shaft up.
2. Wind maximum volume screw ref. see item (50), CW so that piston (44) bottoms out. This positions the cam at approximately zero stroke allowing removal of the drive shaft. *Reference item 1 page 27.*
3. Remove socket head cap screws (9). If disassembling PQ Control version, remove tubing and pass thru fitting (56).
4. Remove cradle assembly (6) from the housing. The M-10 threaded hole in end of the shaft is provided for lifting this assembly.
5. Remove snap ring (4).
6. Remove screws (21) and (47) to remove cam bearings (29) and (42) as applicable.
7. Remove shaft (1), bearing, and seal retainer. Support flat face of the rocker cradle and press end of shaft opposite the bearing end.
8. Remove the shaft seal (1c) from the retainer (1e) if necessary.
9. Remove retaining ring (20).
10. Press bearing off shaft if necessary. Press against bearing inner race.
11. If pump contains a volume indicator assembly (52): *Refer to Figure 2:* Remove indicator pointer (2), retaining ring (9) and pivot nut (1) from pump housing. Remove pivot shaft and fork assembly (3) and (4) through the hole.
11. Remove two screws (34), two washers (25), clearance bearing (24), and two washers (23) from retainer (28).
12. Wind maximum volume screw CCW until piston (44) bottoms out.
13. Remove control cap (50) and control cap (31). (*Refer to controls section for control disassembly*).
14. Insert two tools (T-2) (see page 77) into housing supporting each end of the control piston. The piston must be moved outward (away from pump center) to remove cam assembly.
15. Lift cam assembly (10) from pump. (Link (43), pistons and shoes and retainer plate(17), wear plate (22), and hold-down (45 and 46) are part of the cam assembly.)
16. Remove slide link (43), retaining ring (45), thrust washer (46), pistons, shoes & retainer assembly (17) and wear plate (22). The pins for the slide link and for the indicator have been pressed into the rocker cam and should not be removed.
17. Remove two screws (34), two screws (26), and two retainers (28).
18. Remove Belleville washers (18) and barrel stop (19).
19. Attach tool (T-1) (pg. 65) to barrel assembly (14-1). (Two M6 screws are required.) Lift barrel from port plate and housing.
20. The inner race of bearing (11) has a light press fit with barrel. Do not remove the inner race unless bearing needs to be replaced. If replacement is necessary, remove seven socket head cap screws (12). Replace with 5/16-18 UNC x 6 1/2 in. long soc hd cap screws. Rest assembly on the extended screws. Press barrel from inner race. Care must be taken to avoid damage to barrel face.
21. Remove port plate ref. see item (14), and alignment pin (16), from port block.

The barrel bearing outer race (11) should only be removed from housing if worn, damaged or closer inspection is needed. A bearing puller should be used for removal.

REWORK LIMITS OF WEAR PARTS

item	maximum rework from original dimension	minimum dimension after rework
wear plate	.010", 0,254 mm	.240", 6,096 mm
piston shoe face(pocket)	*	.4175", 10,605 mm

*shoe face pocket depth must be .004", 0,010 mm minimum

WEAR PLATE

The wear plate finish must be 10 µin., 0,25 µm min., flat within .0005", 0,0127 mm and parallel to the backside within .001", 0,0254 mm total indicator reading.

PISTON SHOE

The piston shoe wear face finish must be 45 µin., 1,143 µm min, and must be lapped in a set with the retainer plate. All shoe sole thicknesses to be within .001", 0,0254 mm after lapping. The maximum permissible shoe and piston axial looseness is .010", 0,254 mm.

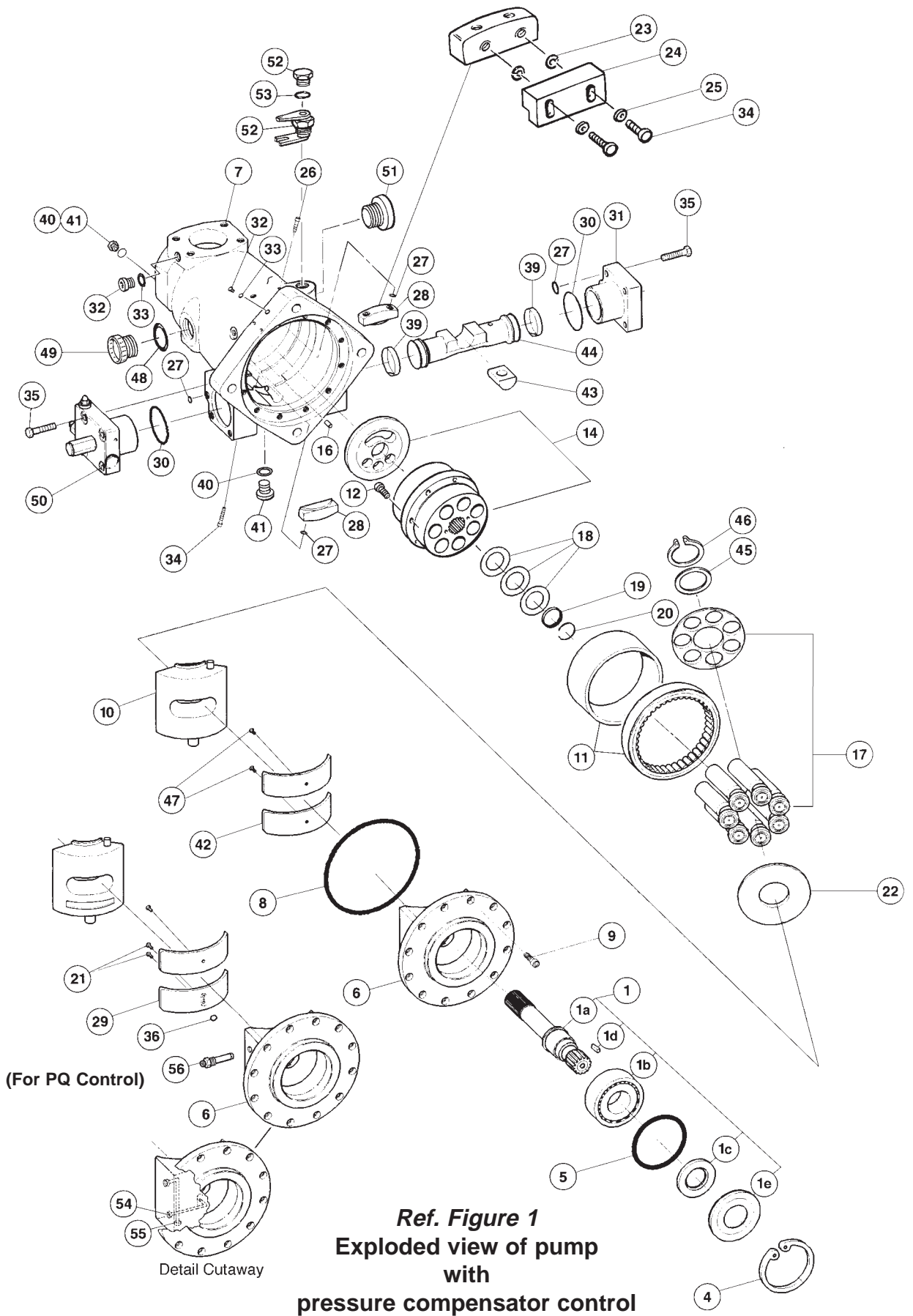

PUMP PARTS LISTS

item	description	part no. P16-SAE	part no. P260-ISO	qty.
1	shaft assembly			1
	keyed, no rear drive	S22-12746	S22-12824	
	a (shaft)	032-91303	032-91319	
	b (bearing)	230-82213	230-82213	
	c (seal)	620-82080	620-82099	
	d (key)	033-71514	032-91429	
	e (seal retainer)	032-91269	032-91269	
	keyed, with rear drive	S22-12859	S22-12864	
	a (shaft)	032-91394	032-91400	
	b (bearing)	230-82213	230-82213	
	c (seal)	620-82080	620-82099	
	d (key)	033-71514	032-91429	
	e (seal retainer)	032-91269	032-91269	
	splined, no rear drive	S22-12747	S22-12825	
	a (shaft)	032-91087	032-91320	
	b (bearing)	230-82213	230-82213	
	c (seal)	620-82080	620-82099	
	e (seal retainer)	032-91269	032-91269	
	splined, with rear drive (standard)	S22-12861	S22-12866	
	a (shaft)	032-91398	032-91399	
	b (bearing)	230-82213	230-82213	
	c (seal)	620-82080	620-82099	
	e (seal retainer)	032-91269	032-91269	
	splined, with rear drive (hi-torque, SAE-F)	S22-12862		
	a (shaft)	032-91365		
	b (bearing)	230-82213		
	c (seal)	620-82099		
	e (seal retainer)	032-91269		
			P260-DIN	
	keyed, no rear drive		S22-15680	
	a (shaft)		032-92224	
	b (bearing)		230-82217	
	c (seal)		620-82051	
	d (key)		032-92246	
	e (seal retainer)		032-92235	
	keyed, with rear drive		S22-15681	
	a (shaft)		032-92225	
	b (bearing)		230-82217	
	c (seal)		620-82051	
	d (key)		032-92246	
	e (seal retainer)		032-92235	
	splined, no rear drive		S22-15682	
	a (shaft)		032-92222	
	b (bearing)		230-82217	
	c (seal)		620-82051	
	e (seal retainer)		032-92235	
	splined, with rear drive		S22-15683	
	a (shaft)		032-92223	
	b (bearing)		230-82217	
	c (seal)		620-82051	
	e (seal retainer)		032-92235	
4	retainer	356-65130	356-65130	1
5	O-ring, 70 S-1 ARP 158	671-00158	671-00158	1
6	cradle	032-91753	032-91754	1
	cradle, PQ control	032-92504	032-92563	
7	housing, no rear drive	032-91744	032-91780	1
	housing, no rear drive, PQ control	032-92515	032-92510	
	housing, with rear drive	032-91779	032-91781	
	housing, with rear drive, PQ control	032-92513	032-92507	
8	O-ring, 70 S-1 ARP 268	671-00268	671-00268	1
9	screw, SHC (16 required in P260)	361-12229	361-11224	12/16
10	cam assembly	S22-15266	S22-15266	1
10	cam assembly, PQ control	S22-15960	S22-15960	1
11	bearing	032-91077	032-91077	1
12	screw, SHC	358-14226	358-14226	7
14	barrel & port plate assembly CW, H*	S22-16100	S22-16100	1
	barrel & port plate assembly CCW, H*	S22-15672	S22-15672	

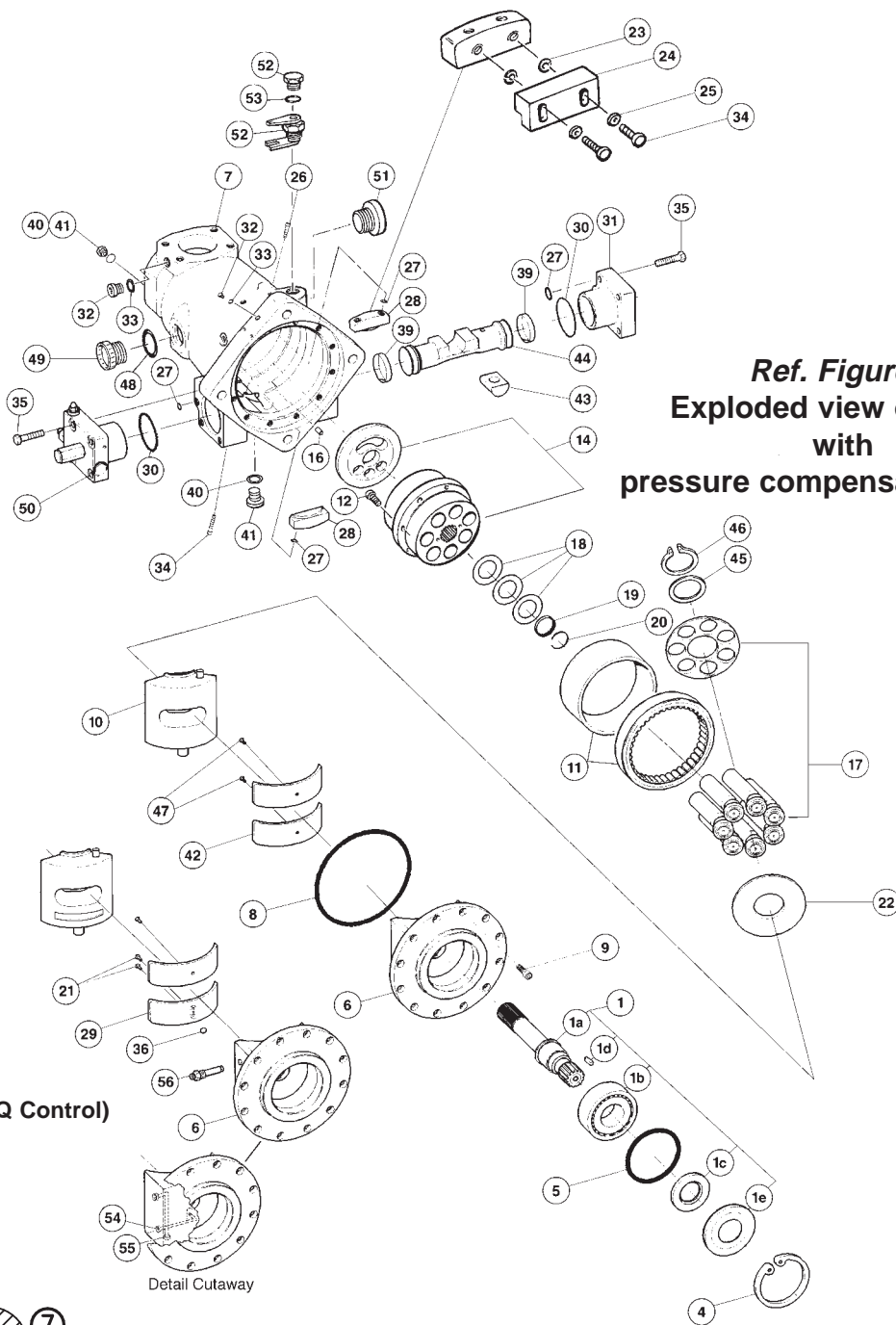

Ref. Figure 1
Exploded view of pump
with
pressure compensator control

(For PQ Control)

Detail Cutaway

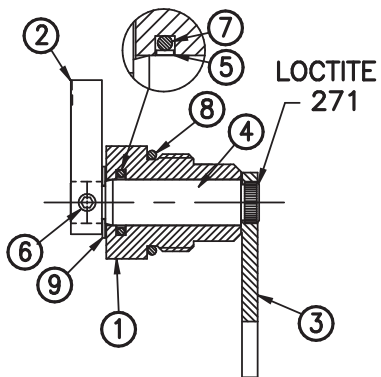

Ref. figure 2
Indicator Assembly (52)
S22-15943

PARTS LIST FOR INDICATOR ASSEMBLY

item	description	part no.	qty.
1	Pivot nut	032-92491	1
2	Indicator	033-70624	1
3	fork	032-92490	1
4	pivot shaft	032-92492	1
5	glyd ring	679-00030	1
6	Soc. setscrew, 10-32 x 3/16	312-09030	1
7	O-ring, 70 S-1 ARP 114	671-00114	1
8	O-ring, 90 S-1 ARP 914	691-00914	1
9	Retaining ring	356-65070	1

PUMP PARTS LISTS

item	description	part no. P16-SAE	part no. P260-ISO	qty.
	barrel & port plate assembly CW, Q*	S22-16123	S22-16123	
	barrel & port plate assembly CCW, Q*	S22-16125	S22-16125	
	barrel & port plate assembly CW, PQ control	S22-15961	S22-15961	
	barrel & port plate assembly CCW, PQ control	S22-15962	S22-15962	
16	dowel pin	324-21610	324-21610	1
17	heavy pistons, shoes,retainer assembly (Q, PQ control)*	S22-15893	S22-15893	1
	(17-1) retainer plate (1 req'd)	032-91750	032-91750	
	(17-2) heavy pistons and shoes (7 req'd)	S22-15892	S22-15892	
	lightweight pistons, shoes,retainer assembly (H)*	S22-15271	S22-15271	
	(17-1) retainer plate (1 req'd)	032-91750	032-91750	
	(17-2) lightweight pistons and shoes (7 req'd)	S22-12728	S22-12728	
18	Belleville washer	032-91083	032-91083	3
19	stop	032-91270	032-91270	1
20	retaining ring	032-91086	032-91086	1
21	screw, button head (PQ control)	353-25079	353-25079	2
22	wear plate	032-91751	032-91751	1
23	lockwasher	348-10016	348-10016	2
24	bearing	032-91412	032-91412	1
25	washer	345-10012	345-10012	2
26	screw, SHC	361-08200	361-08200	2
27	O-ring, 90 S-1 ARP 013	691-00013	691-00013	6
28	cam/bearing retainer	032-91749	032-91749	2
29	bearing, hydrostatic cam (PQ control)	032-92506	032-92506	1
30	O-ring, 70 S-1 ARP 151	671-00151	671-00151	2
31	off stroke control side (see page 17)			1
	buck-up cap (comp, torque limiter, load sensing)	S22-15653	S22-15653	
	electric stroker	S22-16001	S22-16002	
	hydraulic stroker	S22-16003	S22-16004	
	rotary servo	S22-16005	S22-16006	
	PQ control	S22-15963	S22-15964	
32	plug, SAE-4, 1/4 BSPP	488-35061	447-00032	2
33	O-ring, 90 S-1 ARP 904	691-00904	none	2
34	screw, SHC	361-08250	361-08250	4
35	Screw, HHC, M12 x 1,75 x 60 mm lg.	363-12210	363-12210	*
	Screw, HHC, M12 x 1,75 x 80 mm lg.(E,H,R,J,K)	363-12225	363-12225	*
	Screw, HHC, M12 x 1,75 x 90 mm lg. (L)	363-12240	363-12240	*
36	O-ring, 70 S-1 ARP 010 (PQ control))	671-00010	671-00010	1
39	ring (qty. 1 for servo, electric & hyd. stroker)	032-91261	032-91261	2
	ring (servo, electric & hydraulic stroker)	032-91811	032-91811	1
40	O-ring, 90 S-1 ARP 906	691-00906	none	2
41	plug, SAE-6, 1/4 BSPP	488-35041	447-01004	2
42	bearing (1 for PQ control)	032-91345	032-91345	2
43	slide link	032-91259	032-91259	1
44	control piston (compensator, torque limiter)	032-92318	032-92318	1
	control piston (servo, electric & hydraulic stroker)	032-91785	032-91785	
	control piston (PQ control)	032-92505	032-92505	
45	bearing	032-91756	032-91756	1
46	retainer, orange, .063", 1,60 mm thk.	032-92388	032-92388	1
	retainer, blue, .065", 1,65 mm thk.	032-91792	032-91792	
	retainer, red, .067", 1,70 mm thk.	032-91793	032-91793	
	retainer, green, .069" 1,75 mm thk.	032-91794	032-91794	
	retainer, yellow, .071" 1,80 mm thk.	032-91795	032-91795	
	retainer, white, .073" 1,85 mm thk.	032-91796	032-91796	
47	screw, FSHCS (qty. 1 for PQ control)	316-50001	316-50001	2
48	O-ring, 90 S-1 ARP 924	691-00924	none	1
49	plug, SAE-24, 1-1/2 BSPP	488-35062	447-00034	1
50	on stroke control side (see page 17)			1
	compensator	S22-15311	S22-15312	
	low torque limiter	S22-15313	S22-15314	
	high torque limiter	S22-15315	S22-15316	
	load sensing	S22-15536	S22-15537	
	compensator override	S22-16007	S22-16008	
	low torque limiter override	S22-16009	S22-16010	
	high torque limiter override	S22-16011	S22-16012	
	control cap, servo	S22-15256	S22-15272	
	max. volume stop, PQ control	S22-16126	S22-16126	
51	shipping plug	449-00021	449-00021	
52	plug, SAE-14	488-35030	488-35030	1
	indicator assembly (see figure 2)	S22-15943	S22-15943	
53	O-ring, 90 S-1 ARP 914	691-00914	691-00914	1
54	plug, 1/4 pipe (PQ Control)	431-90404	431-90404	1
55	plug, 1/16 pipe (PQ Control)	431-90104	431-90104	1
56	fitting, pass through (PQ Control)	S22-16161	S22-16161	1

*Q means solid piston, H means lightwight piston

REAR DRIVE PARTS LISTS

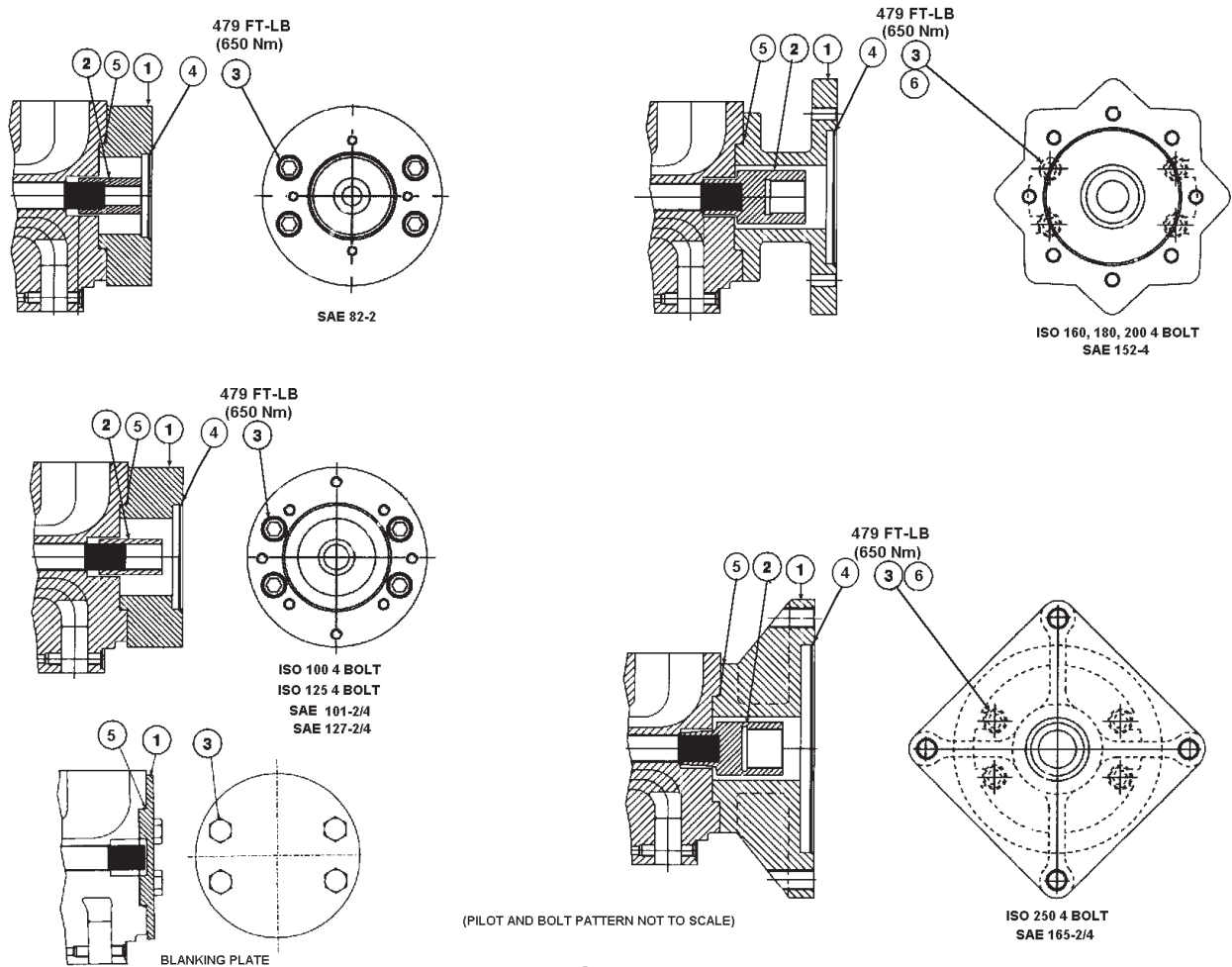

Figure 3
Rear drive options

		SAE REAR DRIVES								
		code	A	G	B	Q	C	N	D	E
		flange	SAE 82-2	SAE 82-2	SAE101-2/4	SAE101-2/4	SAE127-2/4	SAE127-2/4	SAE152-4	SAE165-2/4
		coupling	16-4	22-4	22-4	25-4	32-4	38-4	44-4	44-4
item	part	qty	("A")	(modified "A")	("B")	("B-B")	("C")	("C-C")	("D")	("E")
1	adapter	1	032-91900	032-91900	032-91309	032-91309	032-91308	032-91649	032-91282	032-91283
2	coupling	1	032-91901	032-92377	032-91361	032-91362	032-91363	032-91648	032-91364	032-91364
3	screw	4	361-16304-8	361-16304-8	361-16304-8	361-16304-8	361-16304-8	361-16304-8	363-16250	363-16250
4	O-ring	1	671-00152	671-00152	671-00155	671-00155	671-00159	671-00159	671-00163	671-00272
5	O-ring	1	671-00159	671-00159	671-00159	671-00159	671-00159	671-00159	671-00159	671-00159
6	washer	4							350-10109	350-10109
	assembly		S22-15372	S22-15809	S22-12867	S22-12868	S22-12869	S22-12920	S22-12870	S22-12871

		ISO REAR DRIVES									
		code	Z	Y	X	T	U	L	S	W	V
		flange	ISO 100	ISO 125	ISO 160	ISO 180	ISO 180	ISO 180	ISO 180	ISO 200	ISO 250
		coupling	ISO K25N	ISO K32N	ISO K40N	ISO K40N	ISO K50N	DIN 40-18	DIN 50-24	ISO K50N	ISO K50N
item	part	qty									
1	adapter	1	032-91383	032-91384	032-91385	032-92162	032-92162	032-92162	032-92162	032-91386	032-91387
2	coupling	1	032-91391	032-91390	032-91389	032-91389	032-91388	032-92345	032-92346	032-91388	032-91388
3	screw	4	361-16304-8	361-16304-8	363-16250	361-16304-8	361-16304-8	361-16304-8	361-16304-8	363-16250	363-16250
4	O-ring	1	671-00155	671-00159	671-00164	671-00167	671-00167	671-00167	671-00167	671-00170	671-00272
5	O-ring	1	671-00159	671-00159	671-00159	671-00159	671-00159	671-00159	671-00159	671-00159	671-00159
6	washer	4			350-10109	350-10109	350-10109	350-10109	350-10109	350-10109	350-10109
	assembly		S22-12872	S22-12873	S22-12874	S22-15740	S22-15570	S22-15933	S22-15934	S22-12875	S22-12876

note: item (1) blanking plate part no. 032-91468 item (3) blanking plate screws 363-16210-8

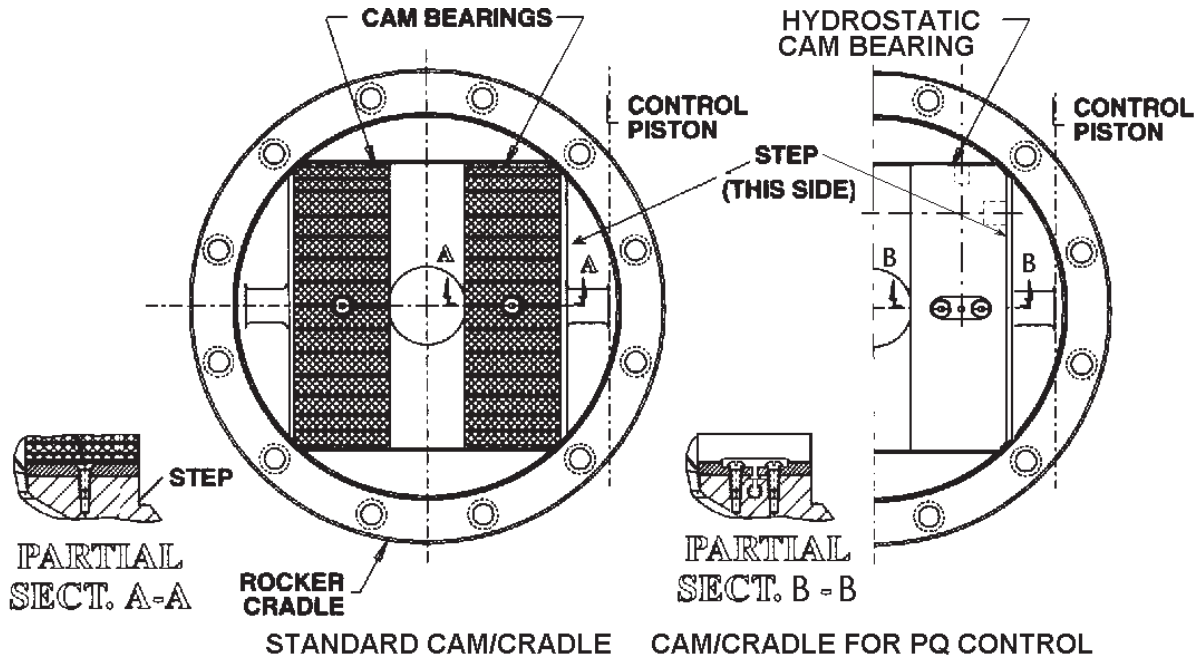

Figure 4
CAM BEARINGS/CRADLE ORIENTATION TO HOUSING

ROTATION CONVERSION

The following parts and assembly are required for changing shaft rotation:

- A different barrel and port plate assembly is required. The barrel and port plate are matched assemblies, and should not be ordered separately. The reference part numbers are:
 CW - Barrel and Port Plate Assembly S22- 16100 (H) S22-16123 (Q) S22-15961 (PQ control)
 CCW - Barrel and Port Plate Assembly S22- 15672 (H) S22-16125 (Q) S22-15962 (PQ control)
- The control piston must be reversed to position it correctly to the control caps. *See step 9 pg. 20*
- The control caps location are reversed. *see illustration below.*

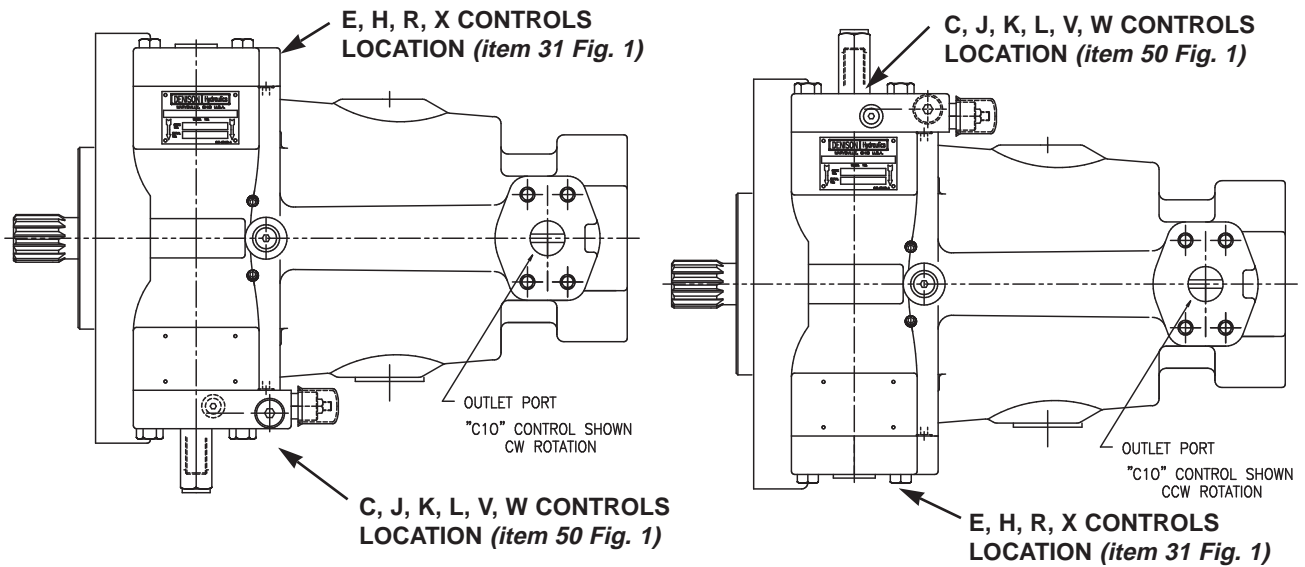
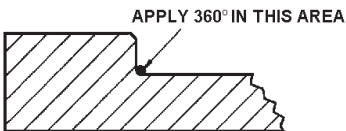

Figure 5
CONTROL ORIENTATION VERSUS PUMP ROTATION

SHAFT SEAL REPLACEMENT

See illustration. Remove worn or damaged seal from retainer. Clean Loctite® "Master Gasket" from retainer. Install new seal by applying "Master Gasket" to retainer and pressing seal in retainer.

SEAL KITS	P16	S22-12830-0
.....	P260 ISO	S22-12831-0
.....	P260 DIN	S22-16160-0



The shaft seal and all "O" rings necessary for total seal replacement may be obtained by ordering the Seal Kit . These seals are suitable for petroleum base fluids. For fire resistant fluids contact **DENISON HYDRAULICS**, Inc. or their authorized distributors to obtain the appropriate seal kit number.

SHAFT ASSEMBLIES

The following assemblies include shaft, key when applicable, bearing and seal:

	P16-SAE #	P260-ISO #
Keyed, no rear drive assembly	S22-12746	S22-12824
Keyed, with rear drive assembly	S22-12859	S22-12864
Splined, no rear drive assembly	S22-12747	S22-12825
Splined, with rear drive assembly	S22-12861	S22-12866
Splined, with rear drive (hi-torque) assembly	S22-12862	

	P260-DIN #
Keyed, no rear drive assembly	S22-15680
Keyed, with rear drive assembly	S22-15681
Splined, no rear drive assembly	S22-15682
Splined, with rear drive assembly	S22-15683

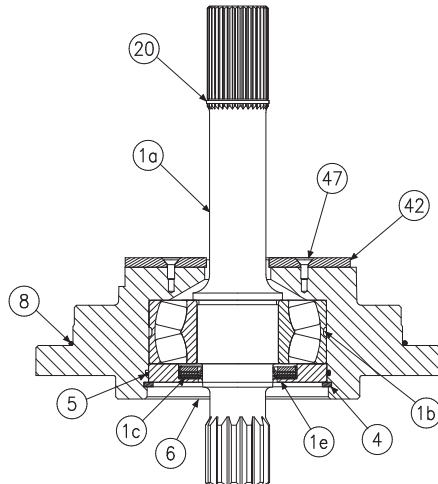

PRE-ASSEMBLY

Depending on the repairs, many steps in this section may not be applicable.

The assembly area should be clean and the environment such that foreign matter will not be introduced to the pump during assembly. All parts must be absolutely clean and free from rust, contamination, lint, or any other foreign matter. Critical surfaces must be free of dings or scratches. All "O" rings and seals must be clean and carefully examined for cuts or other damage before installation.

During assembly, occasional reference will be made to the use of lubricating oil for proper assembly. It is important that any oil used be compatible with the seals and fluid to be used in operation. Compatibility is also necessary for grease which should be used on all "O" rings to ensure proper assembly without damage.

Several screws require a thread lock liquid for locking in position. When required use Loctite® #242 unless otherwise specified.

ASSEMBLY

Refer to illustration, see figure 1

See page 26 for tightening torque on plugs

1. Place the port block end of the housing (7) on a suitable surface capable of supporting the pump weight of 325 lbs, 147.5 Kgs.
2. Install plugs (41) with "O" rings into port block. Install plugs (32) with "O" rings into port block.
3. Install pin (16) in port block. Position port plate (14) on port block and over pin. To view correct port plate for shaft rotation specified, **See illustration, below**

Port Plate for CW Shaft Rotation

Port Plate for CCW Shaft Rotation

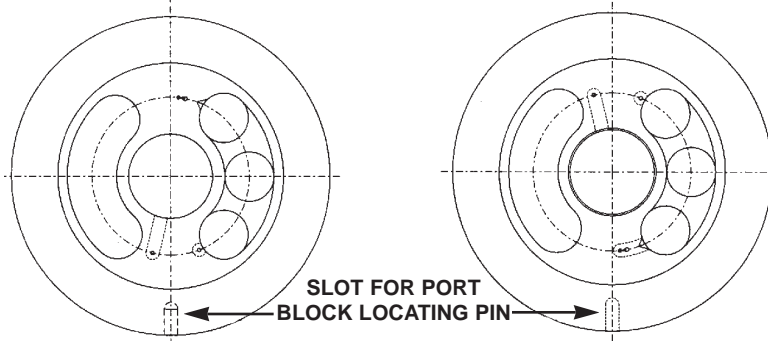

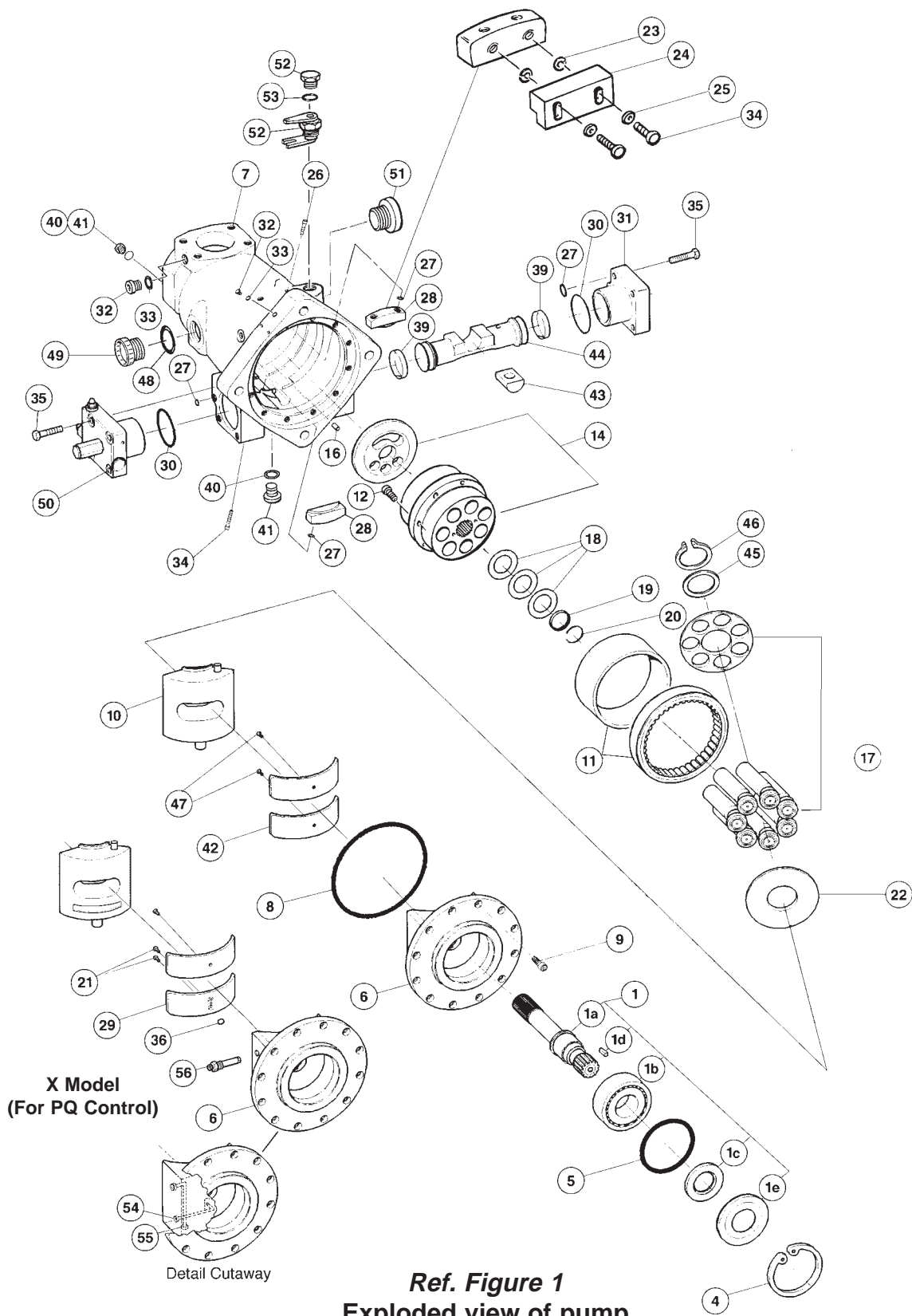

Ref. Figure 1
Exploded view of pump
with
pressure compensator control

- Press bearing outer race (11) into housing (7).

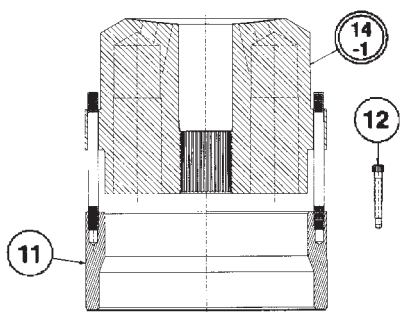

BARREL AND INNER RACE ASSEMBLY

- Thread seven 5/16-18 studs into bearing inner race. Lower barrel (14) over studs and seat. If the inner race is heated to 150°F, 65°C, barrel will slide into position without force. If race is not heated, longer screws (12) can be used to draw the race and barrel together. Insert screws (12) and torque to 30 lbs ft., 40 Nm. **See illustration**
- Apply oil to face of port plate and inner bearing race. Attach tool T-1 to barrel with two M6 screws. Carefully lower barrel assembly into housing engaging inner race into rollers of outer bearing race, barrel may then be lowered until it has seated on port plate.
- Insert two "O" rings (27) into each retainer (28). Apply Loctite® #271 to

- two screws (26) and secure retainer to housing. Torque to 84 lbs-in., 9,5 Nm.
- Apply Loctite® #271 to two screws (34) and assemble the other retainer on opposite side of housing. Torque to 84 lbs-in., 9,5 Nm.
- Assemble the two piston rings (39) on control piston (44). Insert control piston (44) into housing bore that is used with the control caps. **For CW shaft rotation**, the long end of the piston must be positioned to the right. (**Ref. fig.1**) **For CCW rotation**, the long end of the piston is to the left. Insert tools T-2 (page 77, two required) into housing bores, support each end of the control piston. The piston must be moved outward (away from pump center) so that clearance is provided for installing the rocker cam assembly.
- Position Belleville washers (18) on barrel, **See illustration**. To insure proper pump operation and correct barrel holddown force they must be assembled exactly as shown. Place barrel stop (19) on Belleville washers and center the washers and stop on barrel.

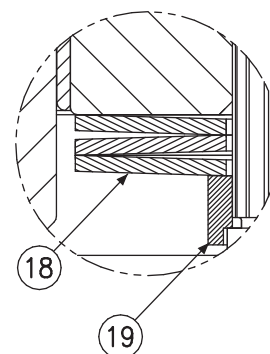

CAM ASSEMBLY

- Set cam assembly (10) on suitable surface protecting cam surfaces from damage during assembly. **See illustration**
- Place wear plate (22) on cam.
- Position pistons-shoes-retainer assembly (17) over center post and against wear plate.
- Install thrust washer (45) over center post.
- Six different retainers (46) are available for setting the shoe holddown. Each retainer is marked: **white dot** .073", 1,85 mm thick, **yellow dot** .071", 1,80 mm thick, **green dot** .069", 1,75 mm thick, **red dot** .067", 1,70 mm thick, **blue dot**

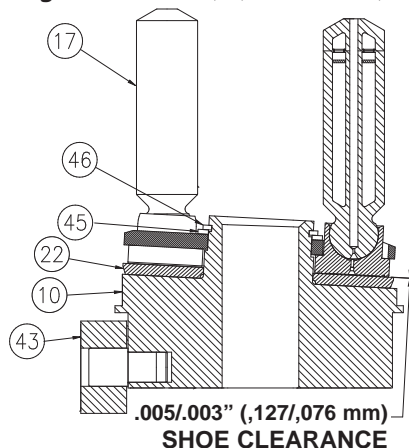

.065", 1,65 mm thick and **orange dot** .063", 1,60 mm thick. Install the thickest retainer **with the dot side up**, that will fit in the groove on the center post and allow a clearance of .003"-.005", 0,076-0,127 mm between the shoe and wear plate. **A .003", 0,076 mm feeler gage must go completely under any shoe, and a .005", 0,127 mm feeler gage must not go under any shoe while holding a piston and lifting tightly against the shoe retainer.** The piston and shoe assembly must be free to rotate easily by hand. Rotate 360° to confirm there is no binding and that each shoe is free in the retainer plate. Oil the assembly thoroughly.

- Install slide link (43) on rocker cam pin as shown.
- Oil barrel bores before installing cam assembly. Lower cam assembly into the housing with the slide link positioned so it will engage into the control piston (44). The seven pistons (17) must first be engaged into the barrel bores. Next the slide link (43) must engage into the control piston (44). Continue lowering rocker cam assembly until it is seated on cam/bearing retain-

- ers(28).
- Apply Loctite 242 to two screws (34) and assemble clearance-bearing (24) to cam-bearing retainer (28) using the screws (34), two washers (25) and two washers (23). Move rocker cam to the right until it is against stop. **Set clearance** between clearance bearing (24) and cam at .006", 0,152 mm. Torque screws to 6 lbs-ft., 8,1 Nm maintaining the .006", 0,152 mm clearance.
- Adjust piston (44) toward the **off stroke** control side (31). This will place the cam at approximately zero stroke and provide clearance for the shaft installation.

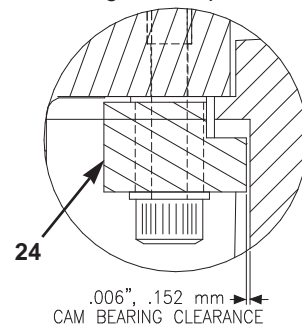

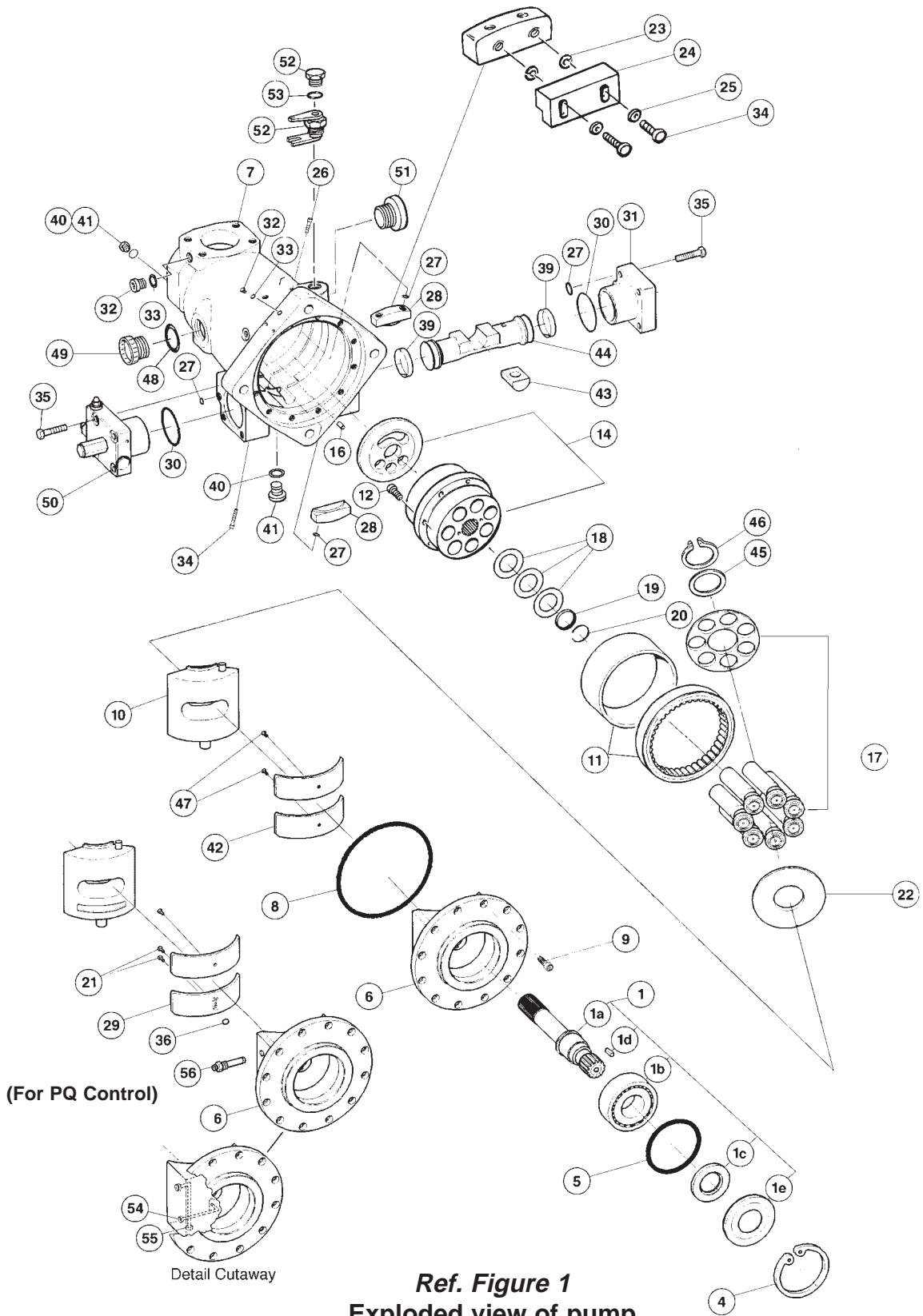

Ref. Figure 1
Exploded view of pump
with
pressure compensator control

- Continued -

Rocker cradle assembly

20. Apply Loctite 242 to two screws (47) and assemble two cam bearings (42) to cradle (6). Torque to 33 lbs-in., 3,8 Nm.

Note: Pumps with PQ control: A special cam, cradle and cam bearing provides a pressure balance to the bearing interface on the control side of the cam. Install plugs (54) and (55) to cradle as shown. Install O-ring (36) in cradle. Apply Loctite 242 to two screws (21) and attach cam bearing (29). Torque to 33 in-lbs, 3,8 Nm.

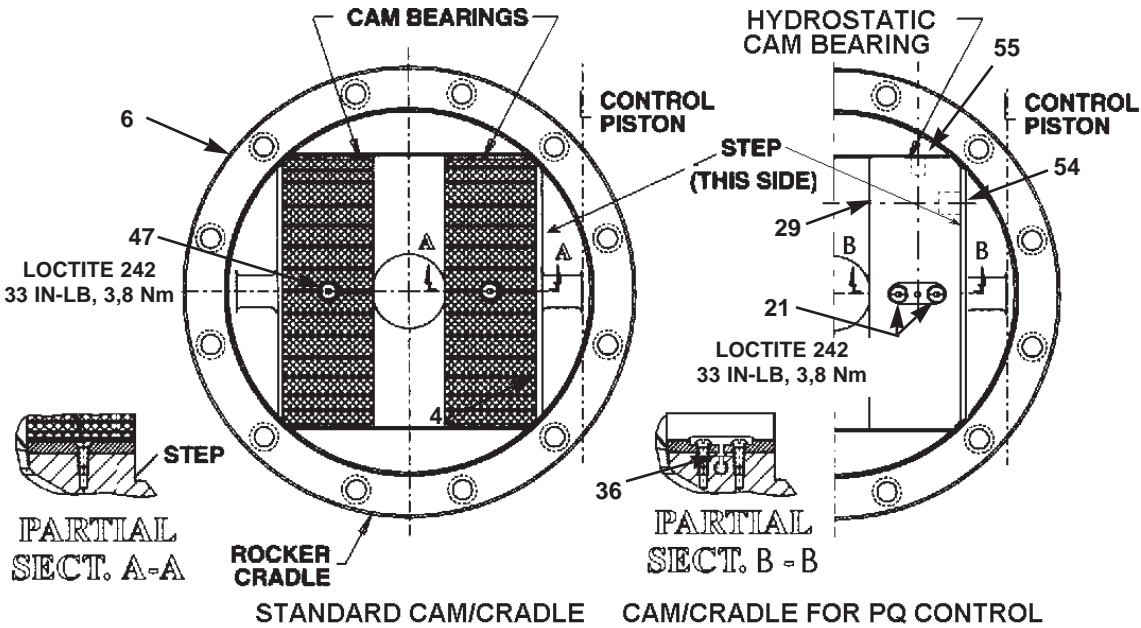

21. Press bearing (1b) on shaft (1a). Press on inner race only.

22. Apply over 360° bead of Loctite® 44 Master Gasket to seal retainer (1e) per following sketch. Press shaft seal (1c) into seal retainer (1e).

23. Install shaft seal and retainer on shaft using Tool T-4 to protect seal.

24. Install "O" ring (5) in cradle (6).

25. Press seal retainer and bearing and shaft assembly into bore of cradle (6) using Tool T-3.

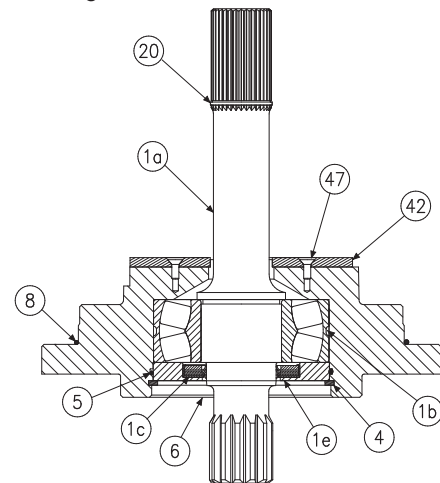
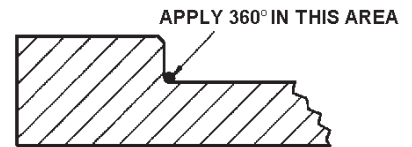

26. Install snap ring (4) to cradle.

27. Install "O" ring (8) to rocker cradle.

28. Install retaining ring (20) on shaft.

29. Center Belleville washers and barrel stop. Lower rocker cradle assembly into pump housing with the step in the rocker cradle correctly positioned so that clearance is provided for slide link (43). The M-10 threaded hole in the end of shaft should be used to support the assembly. The shaft spline must first engage the splined barrel stop (19), thru the Belleville washers (18) and engage the barrel spline. The assembly will then rest on the cam.

30. Install socket head cap screws (9) as shown. Torque evenly to 45-55 ft-lbs (61-75 Nm). Install case drain plug (49) and shipping plug (51). If pump does not contain stroke indicator, install plug (52) and "O" ring (53) in indicator hole.

31. If assembling "X" Model pump, install pass thru fitting (56) into housing, being careful that O-ring enters hole in cradle without damage.

INDICATOR ASSEMBLY OPTION

See figure 2. To install indicator assembly, loosen setscrew (6), remove indicator (2) and slide shaft out of nut (1). Guide fork into indicator hole in housing to engage the pin on the hanger. a 1/4-20 SHCS or threaded rod may be used to hold the shaft. Slide nut (1) over shaft and tighten nut in threaded hole. Pull shaft out to slip retaining ring (9) into groove in shaft. Use maximum volume stop to set pump on zero stroke (10.2 turns from full). Install indicator, set pointer on "0" and lock in position.

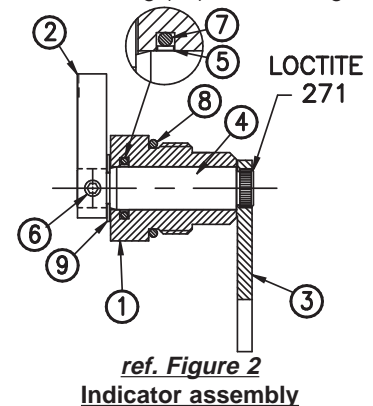

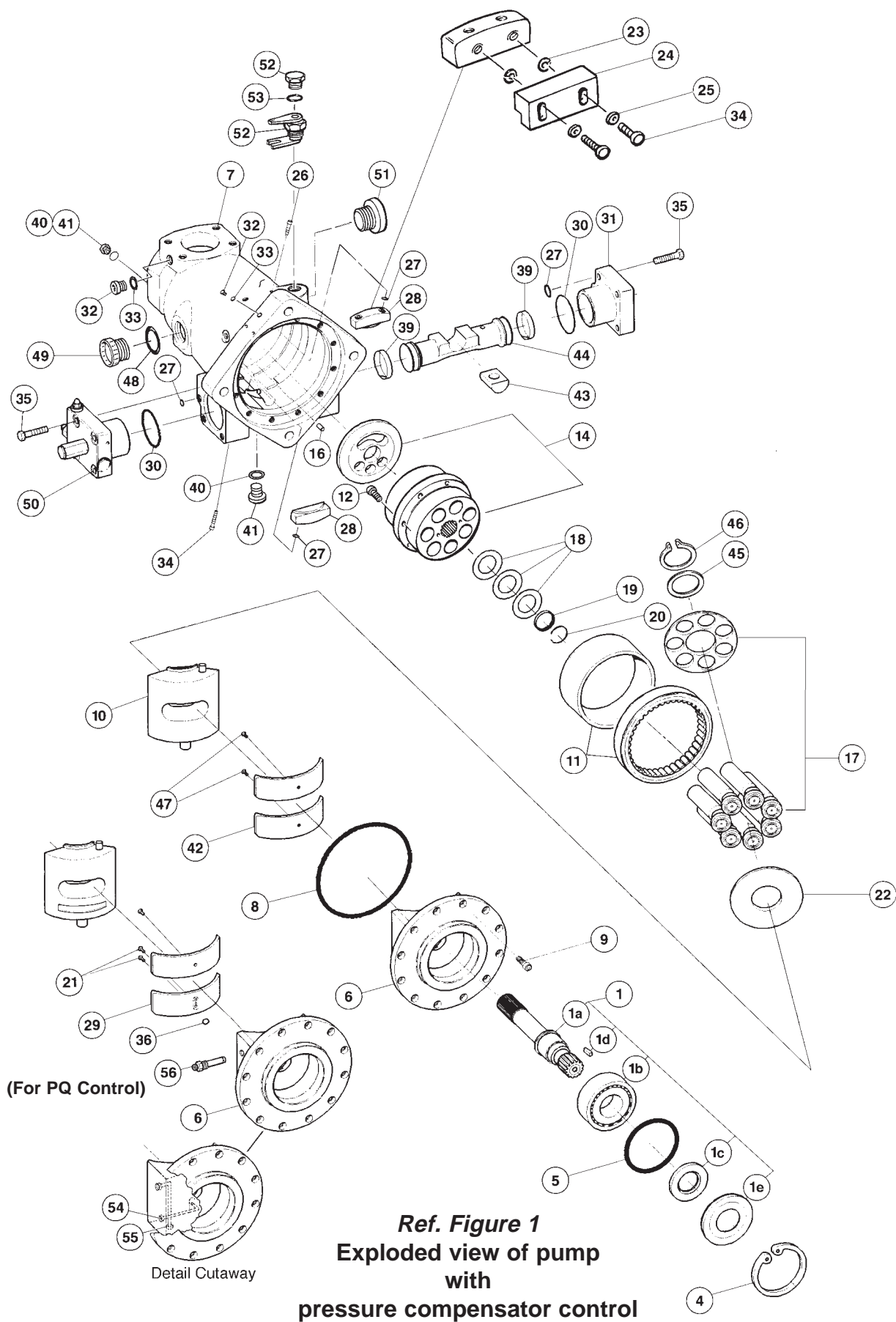

CONTROLS ASSEMBLY

Remove cap tools T-2 from housing and replace with control cap assemblies (50) and (31). The control caps must be positioned on the housing for either CW or CCW pump rotation. See figure 5 for correct orientation. The control piston (44) was assembled previously for the correct pump rotation. Install eight hex head cap screws (35) into caps and torque to housing with 75 lbs-ft., 102 Nm.

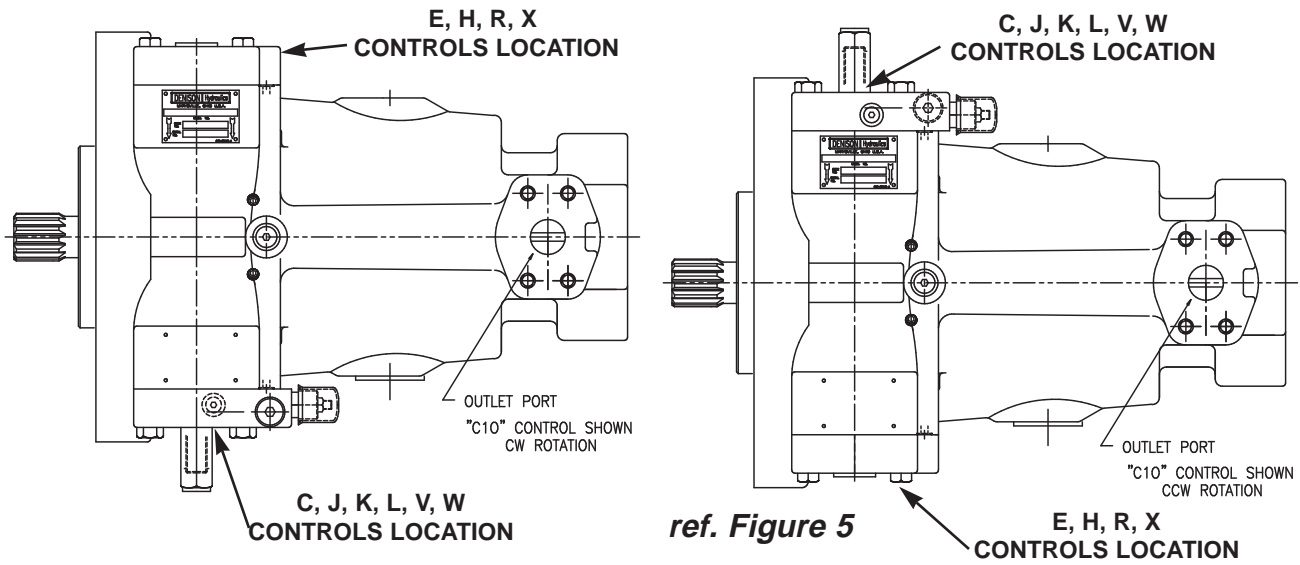

If the pump has a rear drive feature, assemble coupling and adapter. See illustration, figure 4.

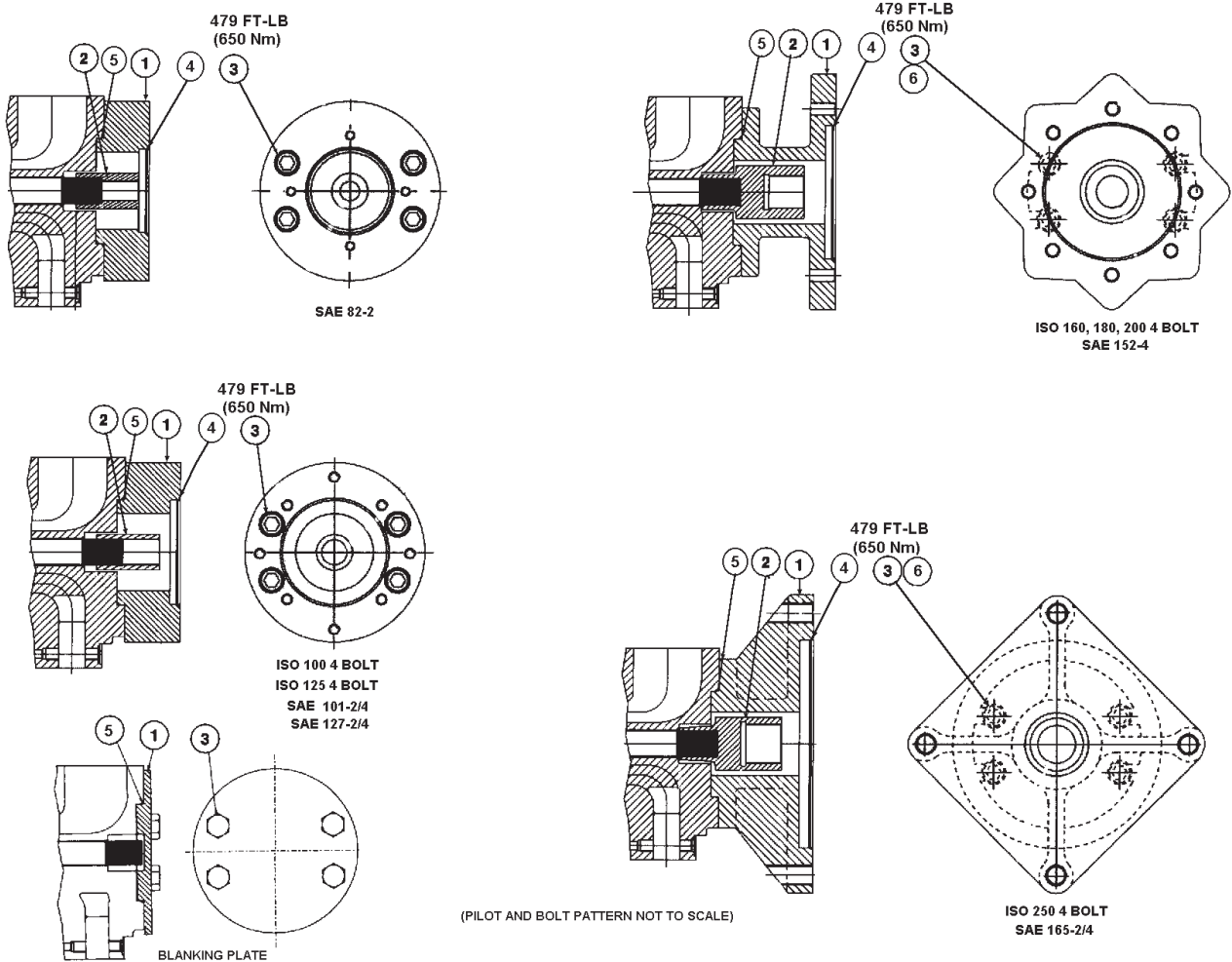

Ref. Figure 4

GENERAL

The instructions contained in this manual cover complete disassembly and reassembly of the controls. Before proceeding with the disassembly or reassembly of any unit, this manual should be studied in order to become familiar with proper order and parts nomenclature

DESCRIPTION OF OPERATION

A pilot operated valve spool and sleeve combination is the core of the control function. For the compensator, torque limiter and load sensing controls, system pressure is applied to the input port of a three-way valve, and to one end of the valve spool. A small orifice feeds this pressure to the other end of the spool, and limits pilot flow to approximately 115 in³/min., 1,9 lpm. A spring on this end biases the spool to normally port the control piston to pump case. This control piston links to the pump cam. On the opposite end of the control piston a small buck-up piston connects to system pressure. This force, pump timing forces, and a spring combine to put the pump on stroke.

PRESSURE COMPENSATOR

A spring-loaded cone and seat connected to the spring end of the three-way spool establishes an adjustable pressure limit on this end of the spool. When system pressure reaches this value, flow through the spool creates a pressure difference across the spool. At approximately 250 psi, 17,2 bar difference, the spool shifts toward the spring, re-directing the control piston port to system pressure. This pressure applied to the control piston overcomes the forces putting the pump on stroke, causing the pump to reduce displacement. When the pump pressure drops, the spool meters to maintain the pump pressure at approximately 250 psi, 17,2 bar above the controlled pressure on the spring side. The spring end of this three-way spool may also be connected to a remote pressure control, through the vent port, "V".

COMPENSATOR WITH LOAD SENSING CONFIGURATION

To use the compensator for load sensing, the "V" port is connected to the load downstream of a metering valve. The pump will supply approximately 250 psi, 17,2 bar difference in pressure across the metering valve, and thus controls flow independent of operating pressure. Adjustment of spring load on the three-way spool allows precise control of the differential pressure.

LOAD SENSING CONTROL

To eliminate the pilot flow, and to control multiple loads, a control designed for load sensing is available. In the load sensing control, the vent flow is modulated by a valve which senses load pressure and establishes the pump compensator pressure at approximately 350 psi to 435 psi, 24,1 to 30 bar above load pressure. There is essentially no flow in the sensing line, and the pump supplies the flow required to develop 350 psi to 435 psi, 24,1 to 30 bar across the metering valve to the load.

TORQUE LIMITER

The product of system pressure and pump displacement must be kept constant for torque limiting. As pressure increases, displacement must reduce, and vice versa. A linkage to the pump control piston slides a sleeve over a pin. The sleeve and pin act as a metering valve. The pin contains a cross drilled hole, and a connecting drilling to one end which is ported to the vent port of the compensator. The pressure in the vent port applies a force on the pin, which is resisted on the other end by a two spring combination.

The pin positions itself to where the vent pressure force on the one end is balanced by the spring force on the other end. When the cross drilled hole opens, it causes the three-way spool to shift to direct system pressure into the control piston, reducing stroke. The linkage to the control piston causes the sleeve to move in the direction to close the cross-drilled hole. Thus, for every position of the pin, there is a corresponding position for the control piston where balance is achieved. At low pressure, high flow, only the outer spring contacts the pin. As pressure increases, the second spring also makes contact. Thus the rate of change of pressure starts at a low initial rate when the pump is at full stroke and changes to a high rate at reduced stroke, to approximate a constant product of pressure times displacement. The normal compensator function is retained to provide a maximum pressure limit.

TORQUE LIMITER WITH LOAD SENSING

A modulating valve is mounted to a torque limiter body to provide a load sensing control with torque limiting and pressure compensator override

ROTARY SERVO CONTROL

The rotary servo control is mounted on the off-stroke side of the control piston. Servo pressure is connected to the input port of a four-way valve, and to the end of this valve spool. A drilling and orifice connects to the opposite end of the spool. One cylinder port connects to the "off stroke" end of the control piston, while the other cylinder port connects to the "on stroke" end of the control piston, through the control on the opposite side.

A rotatable shaft converts to a linear motion on a pin. A sleeve over the pin is driven by a linkage to the control piston. The sleeve/pin combination meters pilot flow from the four-way valve controlling the shifting of the four-way valve, in such a manner that the four-way valve shifts to hold the cylinder position to the corresponding position for the input rotation.

HYDRAULIC STROKER

In the hydraulic stroker, a spring loaded piston is attached to the pin. A control pressure of 50 psi, 3,45 bar causes the piston to commence to move against the spring, to position the pin in proportion to the control pressure, and thus cause the pump to stroke in proportion to control pressure. Full stroke is achieved at 275 psi, 19 bar.

ELECTRIC STROKER

By mounting an electrically modulated pressure control valve on the hydraulic stroker to establish the control pressure, pump stroke is controlled by an electrical signal. For a 24 volt coil, the pump commences to stroke at approximately 175 mA electrical signal, and will be at full stroke at approximately 320 mA.

PRESSURE COMPENSATOR AND TORQUE LIMITER OVERRIDE

An override pressure compensator or a torque limiter control mounts on the smaller diameter of the control piston, opposite the servo, hydraulic or electric stroker. In the normal position, the spool in the override control connects this piston to the control valve on the opposite side, allowing control by the stroker. When system pressure or torque exceed the override setting, this spool connects system pressure to the smaller diameter control piston, to override the rotary servo, hydraulic or electric stroker command and reduce stroke according to the compensator or torque limiter setting. Override pressure must be sufficient to overcome servo pressure acting on the larger diameter piston.

TIGHTENING TORQUE FOR HYDRAULIC PLUGS

PORT SIZE	ft-lbs	Nm
SAE-4	11	15
SAE-6	18	24
SAE-8	46	62
SAE-10	75	102
SAE-14	130	175
SAE-24	250	339
1/4 BSPP	18	24
3/8 BSPP	18	24
1/2 BSPP	93	126
1-1/2 BSP	288	390

PORT SIZES

DESCRIPTION	P16 C MOD	P260 C MOD
PORT C1OFF-STROKE CYL. GAGE.....	SAE-4	.1/4 BSPP
PORT C2ON-STROKE CYL. GAGE	SAE-4	.1/4 BSPP
PORT DCASE DRAIN	SAE-24	.1-1/2 BSPP
PORT D1CASE DRAIN	SAE-24	.1-1/2 BSPP
PORT DG.....DRAIN GAGE, AIR BLEED PORT	SAE-4	.1/4 BSPP
PORT AG.....INLET GAGE	SAE-4	.1/4 BSPP
PORT BG.....SYSTEM GAGE.....	SAE-4	.1/4 BSPP
PORT BG1....ALT. SYS. GAGE.....	SAE-6	.1/4 BSPP
PORT EELECTROHYDRAULIC STROKER SERVO SUPPLY	SAE-4	.1/4 BSPP
PORT HHYDRAULIC STROKER SIGNAL	SAE-4	.1/4 BSPP
PORT LSLOAD SENSING LINE	SAE-4	.1/4 BSPP
PORT VCOMPENSATOR, TORQUE LIMITER, LOAD SENSING VENT	SAE-8	.3/8 BSPP
PORT VOVERRIDE COMP, OVERRIDE TORQUE LIMITER VENT	SAE-4	.1/4 BSPP
PORT V1SERVO VENT	SAE-4	.1/4 BSPP
PORT XSERVO SUPPLY	SAE-8	.3/8 BSPP
PORT XG.....SERVO GAGE	SAE-10	.1/2 BSPP

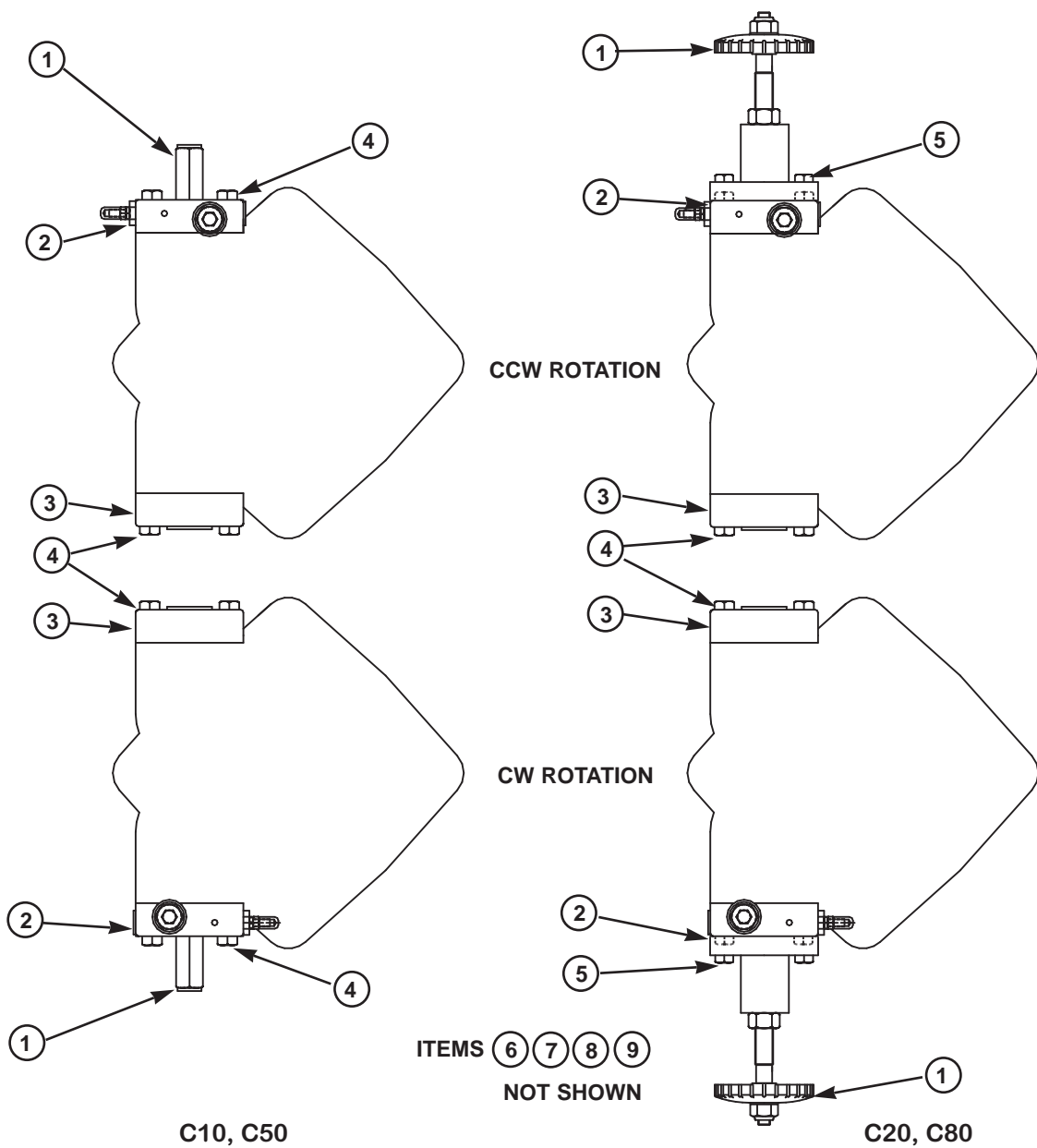

PRESSURE COMPENSATOR

parts list

ITEM	DESCRIPTION	P16 PART NO.	P260 PART NO.	QTY.	
				C10, C50	C20, C80
1	Max. Vol. Stop (Fig. 7)	S22-12983	S22-12983	1	—
	Max Vol. Handwheel (Fig. 8)	S22-12915	S22-12915	—	1
2	*Compensator Control (Fig. 6)	S22-15311	S22-15312	1	-
3	Buck Up Cap (Fig. 9)	S22-15653	S22-15653	1	1
4	Screw-H.H.C., M12 x 60 mm	363-12210	363-12210	8	6
5	Screw-H.H.C., M12 x 80 mm	363-12225	363-12225	—	2
6	Control Piston	032-92318	032-92318	1	1
7	O-Ring, 90 S-1 ARP 013	691-00013	691-00013	2	2
8	O-Ring, 70 S-1 ARP 152	671-00152	671-00152	2	2
9	Piston Ring	032-91261	032-91261	2	2

*Include items 1 (Maximum Volume Stop), 4, 5, 7 and 8

COMPENSATOR DISASSEMBLY

1. **See Figure 6.** Back off max. volume screw or handwheel to full displacement. Remove max. volume screw or hand wheel assembly.
2. Remove bolts holding cap to pump.
3. Remove plug (15) and attached parts. Remove spring (11) and spool (18).
4. Remove adjusting plug (2) and attached parts. Remove seal piston (5). Note: a 10-24 screw may be used to assist in pulling the piston. Remove spring (7) and cone (8).
5. Do not remove sleeve in body (1). Sleeve is pressed into cap and finished to size. If sleeve or cap is worn, replace the cap-sleeve assembly (1).
6. Examine seat (10) for wear. Do not remove unless damaged.

ASSEMBLY***See page 26 for tightening torque on plugs***

1. Install Avseal plugs (9) and orifice (19) in body.
2. Press seat (10) into bore squarely against shoulder in bore.
3. Install spool (18) into bore as shown. Install spring (11) over end of spool. Install O-ring (6) on seal piston (16). Lubricate and install into plug (15). Install plug (15) into cap. Install screw (3), nut (4) and plastic cap (17).
4. Install O-ring (6) on seal piston (5).
5. Lubricate O-ring and install cone (8), spring (7) and seal piston into bore in cap (1), being careful that cone enters seat (10). Install remaining parts. Torque plugs (12) and (21)
6. Note proper location for cap on pump (pg. 24). Install O-rings on interface between cap and pump control pad.
7. Install cap on pump control pad, guiding the control piston into the bore. Install maximum volume stop assembly.
8. Torque mounting bolts to 75 lbs.*ft., 102 Nm.

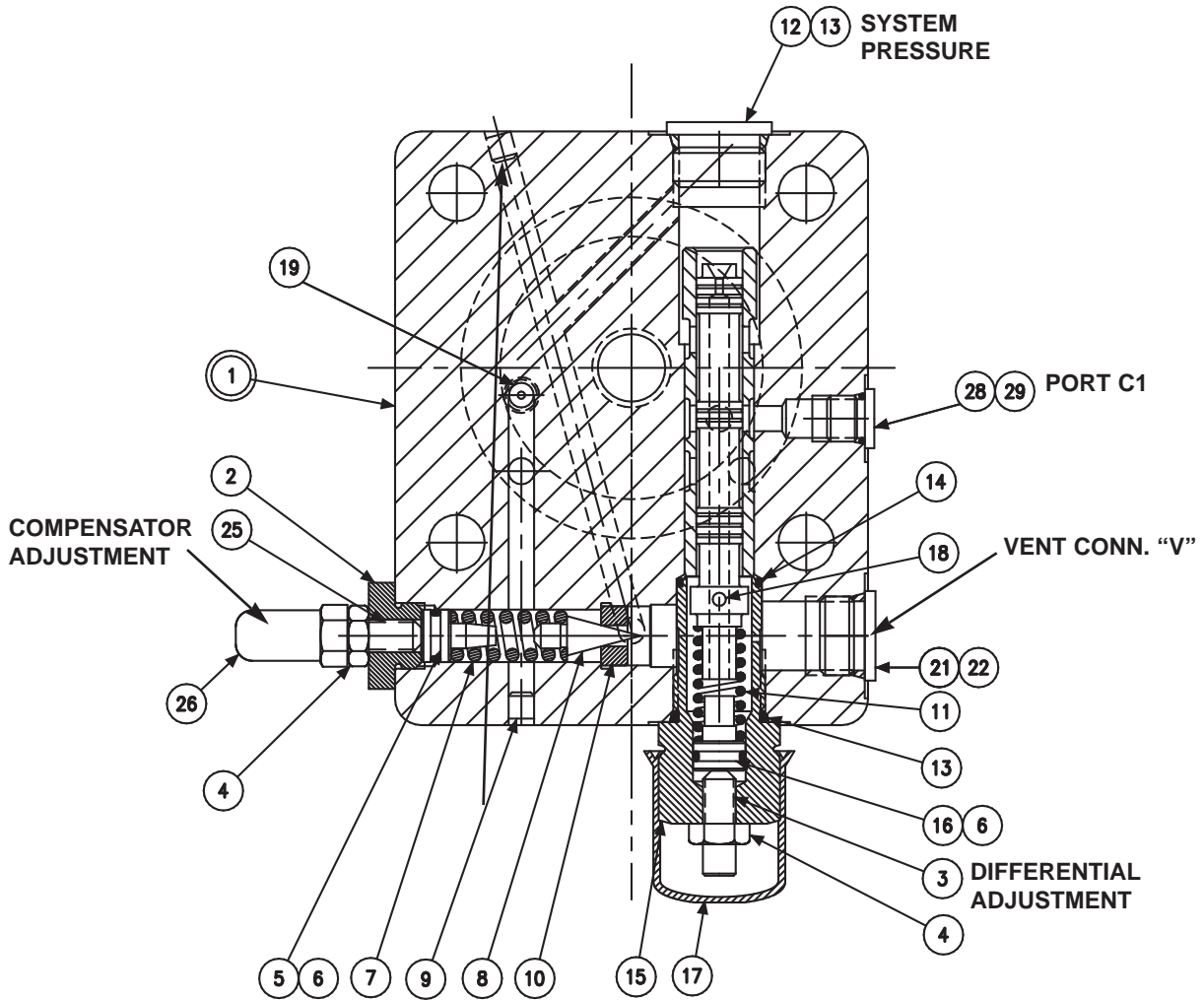

FIGURE 6

PARTS LIST FOR FIGURE 6

P16 code C10, C50 S22-15311
P260 code C10, C50, S22-15312

ITEM	DESCRIPTION	P16		P260	
		PART NO.	QTY.	PART NO.	QTY.
1	Cap-Sleeve Assembly	S22-12880	1	S22-12881	1
2	Adj. Plug	032-91814	1	032-91814	1
3	Soc. Setscrew 5/16-24 x 1	312-13160	1	312-13160	1
4	Nut, 5/16-24	335-13100	2	335-13100	2
5	Seal Piston	031-59367	1	031-59367	1
6	O-Ring, 90 S-1 ARP 012	691-00012	2	691-00012	2
7	Spring	032-91798	1	032-91798	1
8	Cone	036-12288	1	036-12288	1
9	Avseal Plug	447-00026	2	447-00026	2
10	Seat	036-11692	1	036-11692	1
11	Spring	033-71086	1	033-71086	1
12	Plug, SAE-10, 1/2 BSPP	488-35055	1	447-01008	1
13	O-Ring, 90 S-1 ARP 910	691-00910	2	691-00910	1
14	O-Ring, 90 S-1 ARP 017	691-00017	1	691-00017	1
15	Plug	031-57368	1	031-57368	1
16	Seal Piston	032-91305	1	032-91305	1
17	Cap	449-00612	1	449-00612	1
18	Spool	032-59482	1	032-59482	1
19	Orifice Plug	033-25528	1	033-25528	1
21	Plug, SAE-8, 3/8 BSPP	488-35018	1	447-00032	1
22	O-Ring, 90 S-1 ARP 908	691-00908	1	-	-
25	Soc. Setscrew 5/16-24 x 1-1/4	312-13180	1	312-13180	1
26	Acorn Nut	036-33474	1	036-33474	1
28	Plug, SAE-4, 1/4 BSPP	488-35061	1	447-01004	
29	O-ring, 90 S-1 ARP 904	691-00904	1	-	-

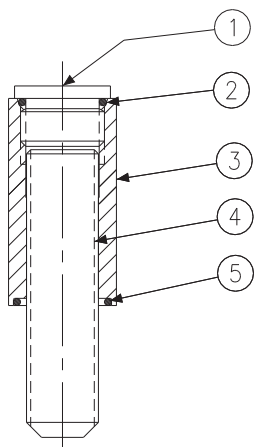

Figure 7
max. volume stop

PARTS LIST FOR FIGURE 7

max. volume stop S22-12983

ITEM	DESCRIPTION	PART NO.	QTY.
1	Plug, SAE-10	488-35055	1
2	O-Ring, 90 S-1 ARP 910	691-00910	1
3	Nut, 3/4 -10UNC Hex	031-91049	1
4	Screw, Soc. Set 3/4 10 x 3	311-26320	1
5	O-Ring,70 S-1 ARP 118	671-00118	1

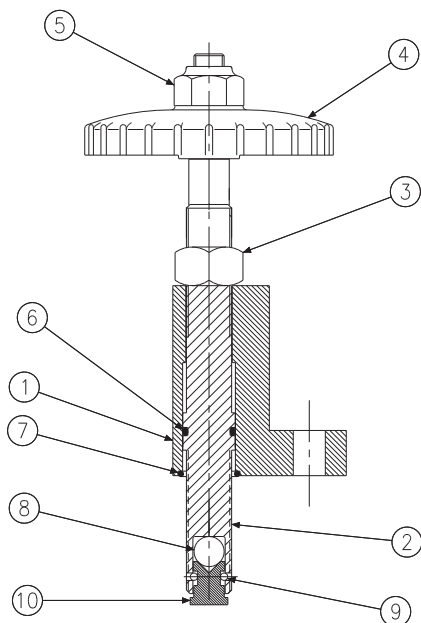

Figure 8
Handwheel maximum volume stop

PARTS LIST FOR FIGURE 8

handwheel S22-12915

ITEM	DESCRIPTION	PART NO.	QTY.
1	Bracket	032-91456	1
2	Screw	032-91455	1
3	Nut, Hex 3/4-16 UNC	333-25000	1
4	Handwheel	031-59911	1
5	Nut, Elastic Stop 1/2-13	331-20100	1
6	O-Ring, 90 S-1 ARP 115	691-00115	1
7	O-Ring, 90 S-1 ARP-118	691-00118	1
8	Ball	201-16001	1
9	Ball	201-04001	2
10	Seat	032-91454	1

MAXIMUM VOLUME HANDWHEEL DISASSEMBLY

1. See Fig. 8. Remove the two screws holding the bracket (1) to the control cap.
2. Turn the handwheel counter-clockwise to remove the stop screw from the control cap.
3. Remove nut (5) and handwheel (4) from the stop screw (2).
4. Remove nut (3). Screw (2) may now be slipped through the bracket (1) to examine parts and to replace O-ring (6).
5. Seat (10) pivots and rotates on ball (8) and is retained by pressing two balls (9) into screw (2). Replace assembly if damaged.

ASSEMBLY

1. Install ball (8) and seat (10) in screw (2).
2. Press balls (9) into screw (2) to retain seat
3. Install O-ring (6) on screw (2). Lubricate O-ring and slide screw into bracket (1). Install remaining parts.
4. Turn handwheel clockwise into cap till the screw contacts the control piston.
5. Install and torque the assembly screws to 75 ft-lb, 102 Nm.

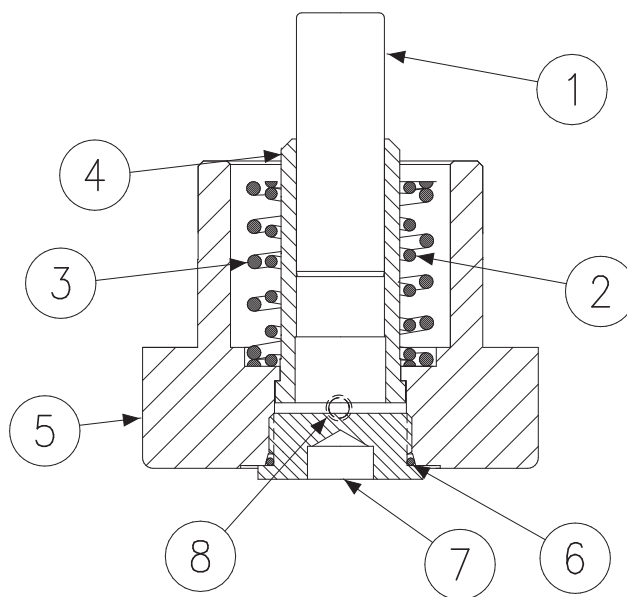

FIGURE 9
Buck-up cap assembly

PARTS LIST FOR FIGURE 9
buck-up cap S22-15653

ITEM	DESCRIPTION	PART NO.	QTY.
1	Piston	324-26448	1
2	Spring	032-92244	1
3	Spring	032-92316	1
4	Sleeve	032-92247	1
5	Control Cap	032-92248	1
6	O-Ring	691-00920	1
7	Plug, SAE-20	488-35019	1
8	Avseal Plug	447-00026	1

BUCK-UP CAP DISASSEMBLY

1. **See Figure 9.** Set maximum volume stop to full stroke. Remove 4 screws holding cap to pump. Caution! Spring load could cause injury!
2. Remove cap assembly from pump.
3. Remove and examine springs (2), (3) and piston (1). If sleeve (4) is worn, press it out and replace.

ASSEMBLY

1. Install Avseal plug (8) into cap. Press sleeve (4) into cap to shoulder. Install piston (1), O-ring (6) and plug (7) into cap.
2. Install O-rings on interface between cap and pump control pad. Install spring (2) and spring (3) into control piston. Install cap assembly on pump housing as indicated on page 17 Fig. 5, guiding the control piston into the bore.
3. Torque the assembly bolts to 75 ft-lb, 102 Nm. Torque plug (7) to 225 lb-ft, 305 Nm.

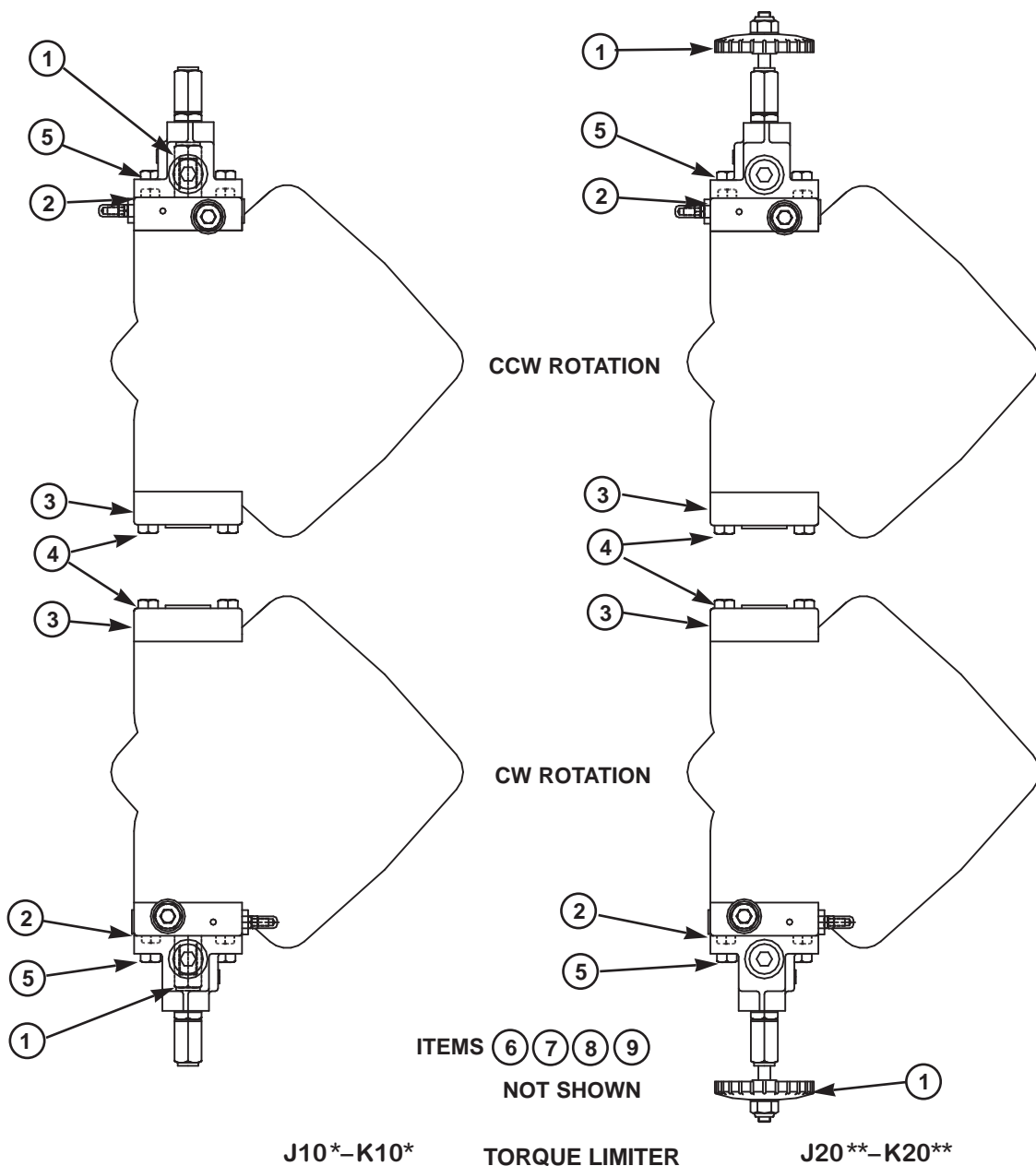

PARTS LIST
torque limiter

ITEM	DESCRIPTION	P16 PART NO	P260 PART NO.	QUANTITY			
				J10*	K10*	J20**	K20**
1	Maximum Volume Stop (Fig. 7)	S22-12983	S22-12983	1	1	—	—
	Max Vol. Handwheel (Fig. 8)	S22-12915	S22-12915	—	—	1	1
2	***Low Torque Limiter (Fig. 11)	S22-15313	S22-15314	1	—	-	—
	***High Torque Limiter (Fig. 11)	S22-15315	S22-15316	—	1	—	-
3	Buck Up Cap (Fig. 9)	S22-15653	S22-15653	1	1	1	1
4	Screw-H.H.C., M12 x 60 mm	363-12210	363-12210	6	6	4	4
5	Screw-H.H.C., M12 x 80 mm	363-12225	363-12225	2	2	4	4
6	Control Piston	032-92318	032-92318	1	1	1	1
7	O-Ring, 90 S-1 ARP 013	691-00013	691-00013	2	2	2	2
8	O-Ring, 70 S-1 ARP 152	671-00152	671-00152	2	2	2	2
9	Piston ring	032-91261	032-91261	2	2	2	2

* Also J50, K50

**Also J80, K80

***Include items 1 (Maximum Volume Stop), 4, 5, 7 and 8

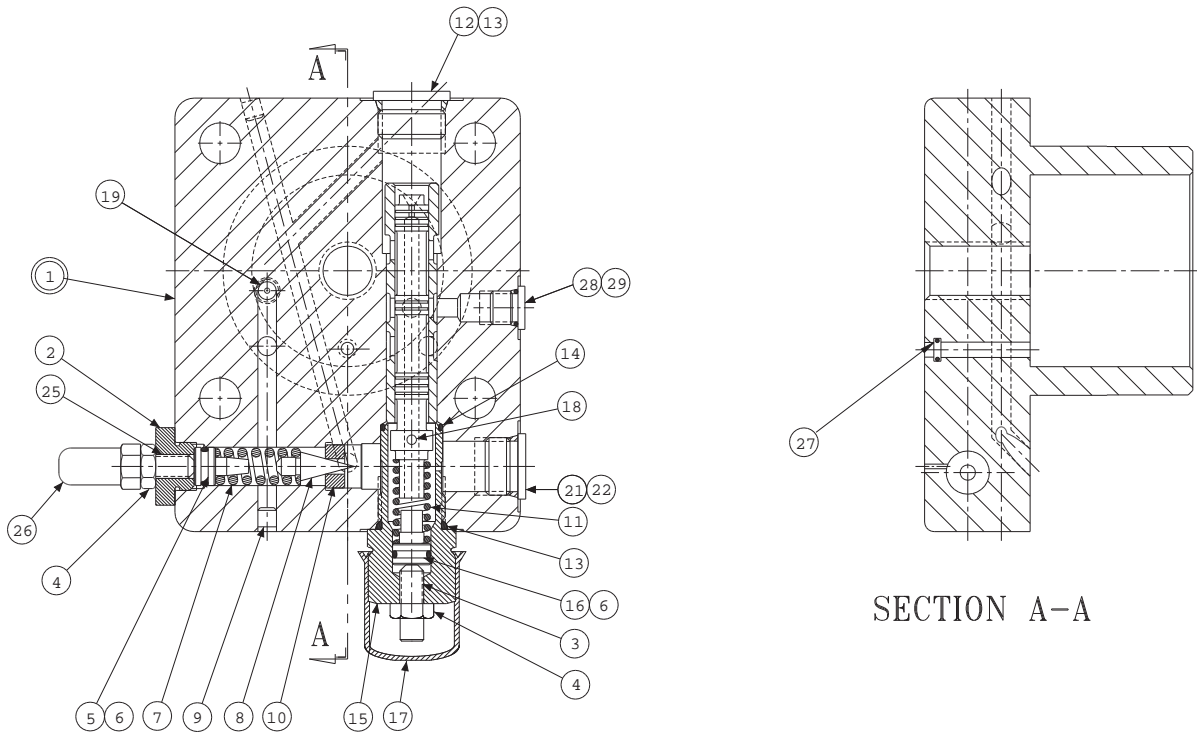

FIGURE 10
Torque limiter cap

PARTS LIST FOR FIGURE 10
P16 torque limiter cap S22-12913
P260 torque limiter cap S22-12923

ITEM	DESCRIPTION	P16		P260	
		PART NO.	QTY.	PART NO.	QTY.
1	Cap-Sleeve Assembly	S22-12912	1	S22-12922	1
2	Adj. Plug	032-91814	1	032-91814	1
3	Soc. Setscrew 5/16-24 x 1	312-13160	1	312-13160	1
4	Nut, 5/16-24	335-13100	2	335-13100	2
5	Seal Piston	031-59367	1	031-59367	1
6	O-Ring, 90 S-1 ARP 012	691-00012	2	691-00012	2
7	Spring	032-91798	1	032-91798	1
8	Cone	036-12288	1	036-12288	1
9	Avseal Plug	447-00026	2	447-00026	2
10	Seat	036-11692	1	036-11692	1
11	Spring	033-71086	1	033-71086	1
12	Plug- SAE-10, 1/2 BSPP	488-35055	1	447-01008	1
13	O-Ring, 90 S-1 ARP 910	691-00910	2	691-00910	1
14	O-Ring, 90 S-1 ARP 017	691-00017	1	691-00017	1
15	Plug	031-57368	1	031-57368	1
16	Seal Piston	032-91305	1	032-91305	1
17	Cap	449-00612	1	449-00612	1
18	Spool	032-59482	1	032-59482	1
19	Orifice	033-25528	1	033-25528	1
21	Plug- SAE-8, 3/8 BSPP	488-35018	1	447-00032	1
22	O-ring, 70 S-1 ARP 908	691-00908	1	-	-
25	Soc. Setscrew 5/16-24 x 1-1/4	312-13180	1	312-13180	1
26	Nut, Acorn 5/16-24	036-33474	1	036-33474	1
27	O-Ring, 70 S-1 ARP 008	671-00008	1	671-00008	1
28	Plug - SAE-4, 1/4 BSPP	488-35061	1	447-01004	1
29	O-ring 90 S-1 ARP 904	691-00904	1	-	-

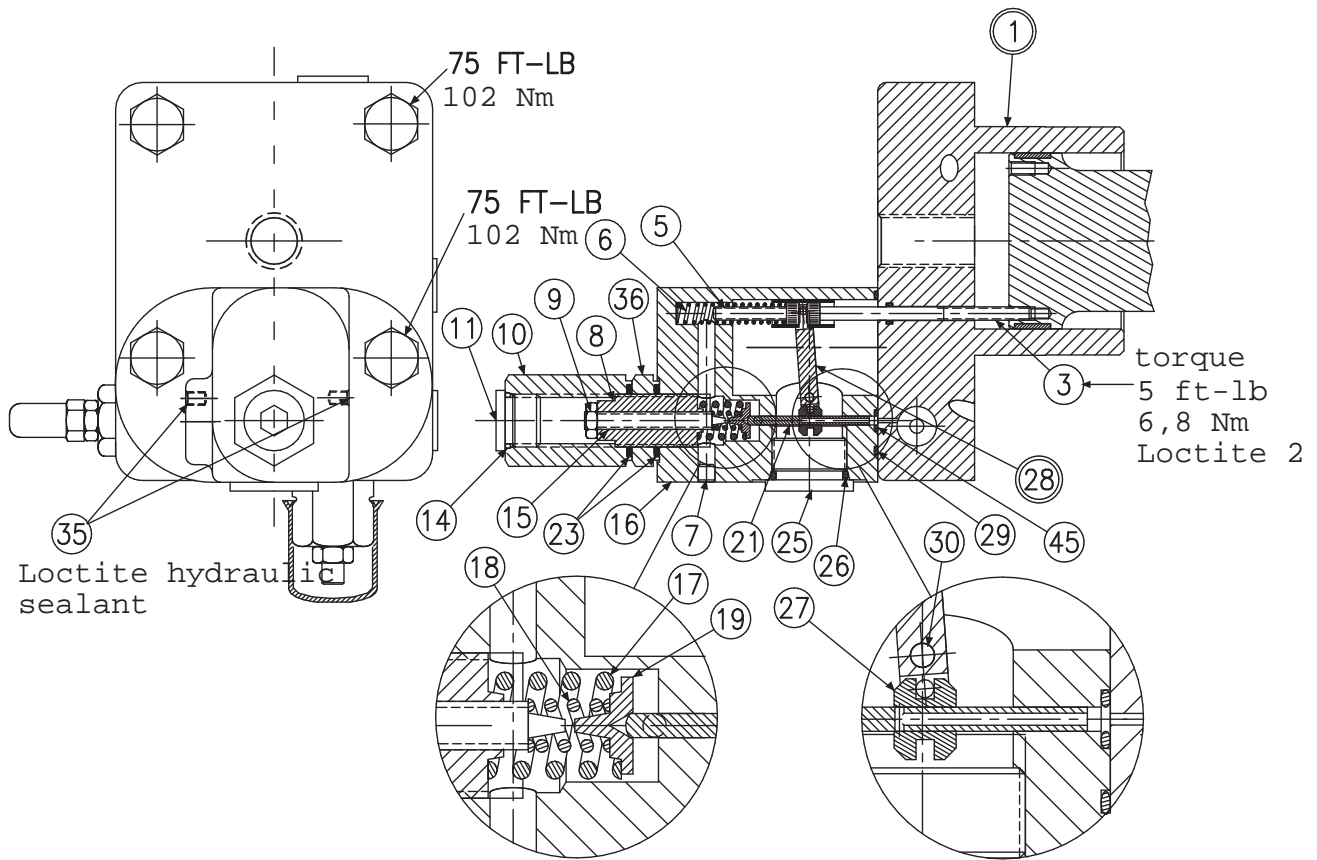

FIGURE 11
Torque Limiter

PARTS LIST FOR FIGURE 11

P16 code J10, J50, S22-15313

P16 code K10, K50, S22-15315

P260 code J10, J50, S22-15314

P260 code K10, K50, S22-15316

ITEM	DESCRIPTION	P16	P260	QTY.	
		PART NO.	PART NO.	J	K
1	Cap (Figure 10)	S22-12913	S22-12923	1	1
3	Screw	032-91461	032-91461	1	1
5	Clevis pin	321-40000	321-40000	1	1
6	Spring, Compression	032-92100	032-92100	1	1
7	Plug, Avseal	447-00026	447-00026	1	1
8	Screw	032-91445	032-91445	1	1
9	Nut, Hex Jam 1/4-20 UNC	340-00038	340-00038	1	1
10	Hex Nut, 3/4-16 UNF	032-91449	032-91449	1	1
11	Plug, SAE-8	488-35018	488-35018	1	1
14	O-Ring, 90 S-1 ARP 908	691-00908	691-00908	1	1
15	Screw, Primary Adjust	032-91446	032-91446	1	1
16	Body assembly	S22-15396	S22-15396	1	1
17	Outer Spring – J Version	032-91440	032-91440	1	—
	Outer Spring – K Version	032-91448	032-91448	—	1
18	Inner Spring – J Version	032-91441	032-91441	1	—
	Inner Spring – K Version	032-91447	032-91447	—	1
19	Spring Retainer	032-91819	032-91819	1	1
21	Spool	032-91438	032-91438	1	1
23	O-ring, 70 S-1 ARP 118	671-00118	671-00118	2	2
25	Plug, 12 SAE-12	488-35014	488-35014	1	1
26	O-Ring, 90 S-1 ARP 912	691-00912	691-00912	1	1
27	Sleeve	032-91437	032-91437	1	1
28	Arm assembly	S22-15520	S22-15520	1	1
29	O-Ring, 70 S-1 ARP 035	671-00035	671-00035	1	1
30	Dowel Pin, 1/8 Dia. x 1.75 Lg.	324-20828	324-20828	1	1
35	Screw, SHC 10-32 x 1/4	312-09041	312-09041	2	2
36	Nut	032-91645	032-91645	1	1
45	O-Ring, 70 S-1 ARP 010	671-00010	671-00010	1	1

DISASSEMBLY

1. See Figure 11. Remove 2 screws holding torque limiter body (16) to cap assembly (1).
2. Remove all parts from torque limiter body (16) except pin (30) and arm assembly (28). It is not necessary to remove these parts unless broken or worn. Examine parts for wear or damage.
3. Remove screw (3). Examine head for excessive wear, and body for smooth sealing surface with O-ring.
4. Remove maximum stop handwheel assembly or maximum stop screw assembly.
5. Remove cap assembly (1).
6. See Figure 10. Remove plug (15) and attached parts. Remove spring (11) and spool (18).
7. Remove adjusting plug (2) and attached parts. Remove spring (7) and cone (8).
8. Do not remove sleeve in body (1). Sleeve is pressed into cap and finished to size. If sleeve or cap is worn, replace the cap-sleeve assembly (1).
9. Examine seat (10) for wear. Do not remove unless damaged.

ASSEMBLY

See page 26 for tightening torque on plugs

1. See Figure 10. Install Avseal plugs (9) and orifice (19) in body.
2. Press seat (10) into bore squarely against shoulder in bore.
3. Install spool (18) into bore as shown. Install spring (11) over end of spool. Install O-ring (6) on seal piston (16). Lubricate and install into plug (15). Install plug (15) into cap. Install screw (3), nut (4) and acorn nut (17). Install plug (12). Torque plugs to 75 lb.*ft., 102 Nm. Install plug (21). Torque to 46 lb.*ft., 62 Nm. Install plug (28). Torque to 11 lb.*ft., 15 Nm.
4. Install O-ring (6) on seal piston (5). Lubricate O-ring and install cone (8), spring (7) and seal piston (5) into bore in cap (1), being careful that cone enters seat (10). Install adj. plug (2), screw (25), nut (4) and acorn nut (26).
5. Carefully install O-ring (27) in the cap.
6. Note proper location for control cap (pg. 24). Install O-rings on interface between cap and pump control pad. Install cap, guiding control piston into bore. Torque mounting screws to 75 lb.*ft., 102 Nm.
7. Install maximum volume handwheel or screw assembly. Set stop to clear control piston.
8. See Figure 11. Apply Loctite 242 on threads of screw (3), lubricate the shank, thread through the cap into the control piston, and torque to 5 lb.*ft., 6,8 Nm
9. Measure height from control cap to top of screw. With control piston at full stroke, dimension must be 1.50 +/- .03 in., 38,1 +/- 0,76 mm.
10. Press dowel (30) into body (16), through the link assembly (28), to 1/4", 6,35 mm below surface. Apply Loctite hydraulic sealant to threads of screws (35) and install over dowel (30).
11. While sleeve (27) is engaged into dowel on link (28), slide spool (21) into bore of body (16), and through sleeve (27). Spool (21) must move freely and easily at all positions of the link (28).
12. Assemble remaining parts per drawing. While spring retainer is engaging clevis pin (5) under dowel of link (28), slide the other opening of spring retainer over the top of the screw (3). Attach body assembly (16) to cap (1) and torque screws to 75 lb.*ft., 102 Nm.

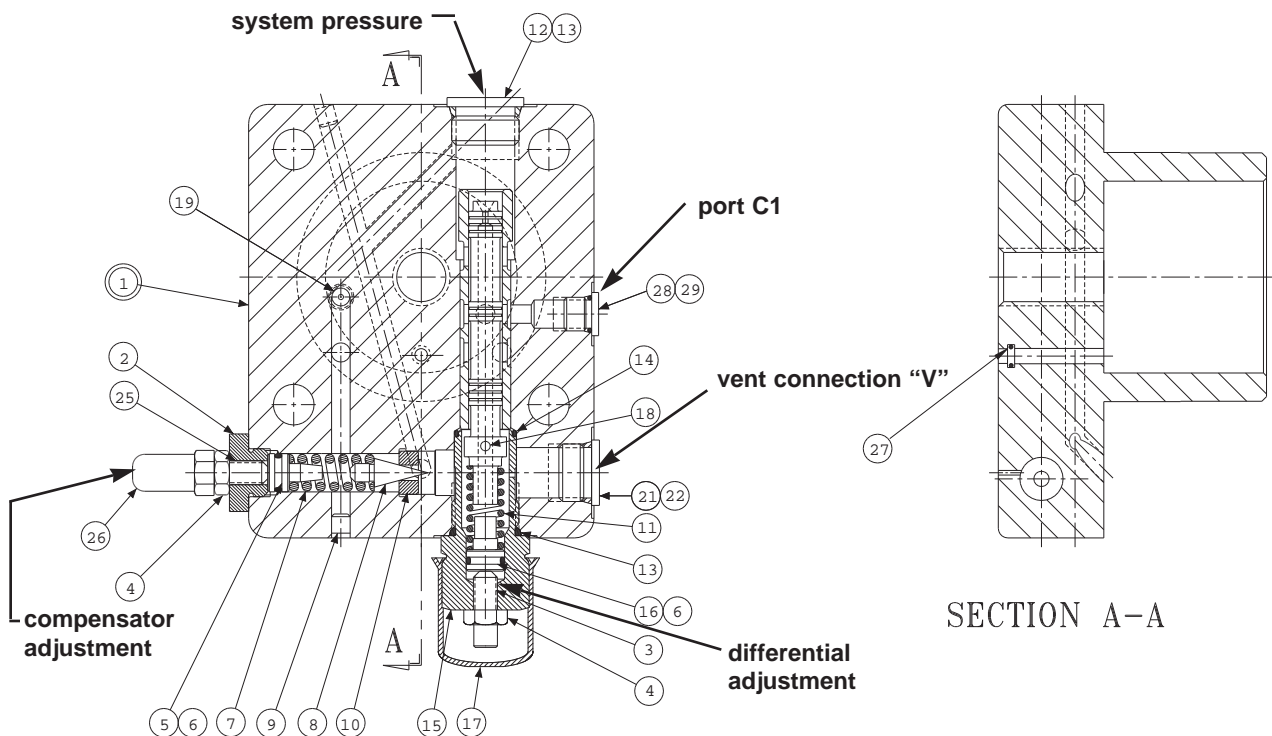

Ref. Figure 10
Torque limiter cap

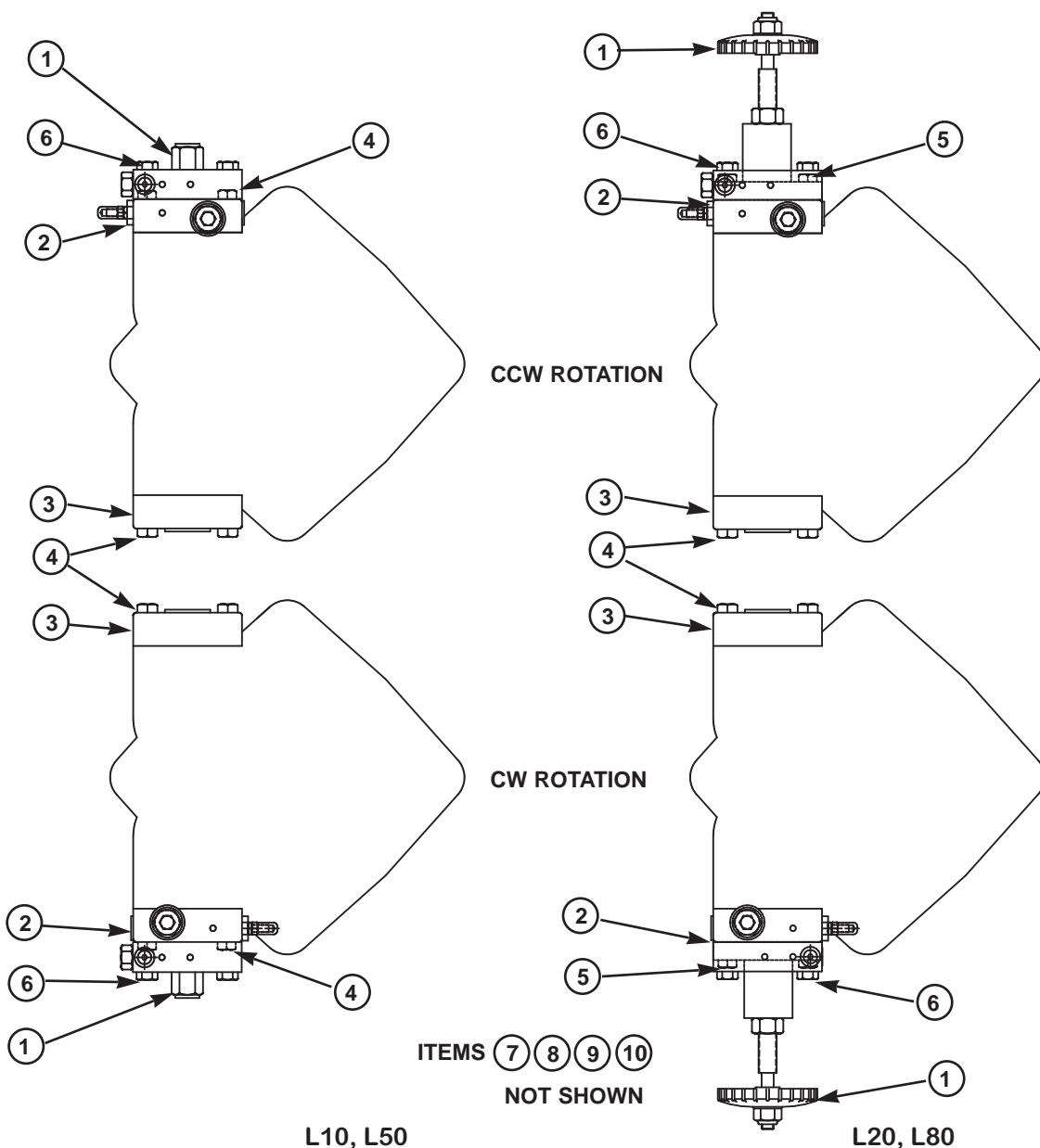

LOAD SENSING CONTROL

parts list

ITEM	DESCRIPTION	PART NO.		QTY.	
		P16	P260	L10, L50	L20, L80
1	Maximum Volume Stop (Fig. 7)	S22-12983	S22-12983	1	—
	Max Volume Handwheel (Fig. 8)	S22-12915	S22-12915	—	1
2	*Load Sensing Control (Fig. 12)	S22-15536	S22-15537	1	—
3	Buck Up Cap (Fig. 13)	S22-15653	S22-15653	1	1
4	Screw-H.H.C., M12 x 60 mm	363-12210	363-12210	6	4
5	Screw-H.H.C., M12 x 80 mm	363-12225	363-12225	—	2
6	Screw-H.H.C. M12 x 90 mm	363-12240	363-12240	2	2
7	Control Piston	032-92318	032-92318	1	1
8	O-Ring, 90 S-1 ARP 013	691-00013	691-00013	2	2
9	O-Ring, 70 S-1 ARP 152	671-00152	671-00152	2	2
10	Piston Ring	032-91261	032-91261	2	2

*Include items 1 (Maximum Volume Stop), 4, 6, 8 and 9

LOAD SENSING PRESSURE COMPENSATOR CONTROL

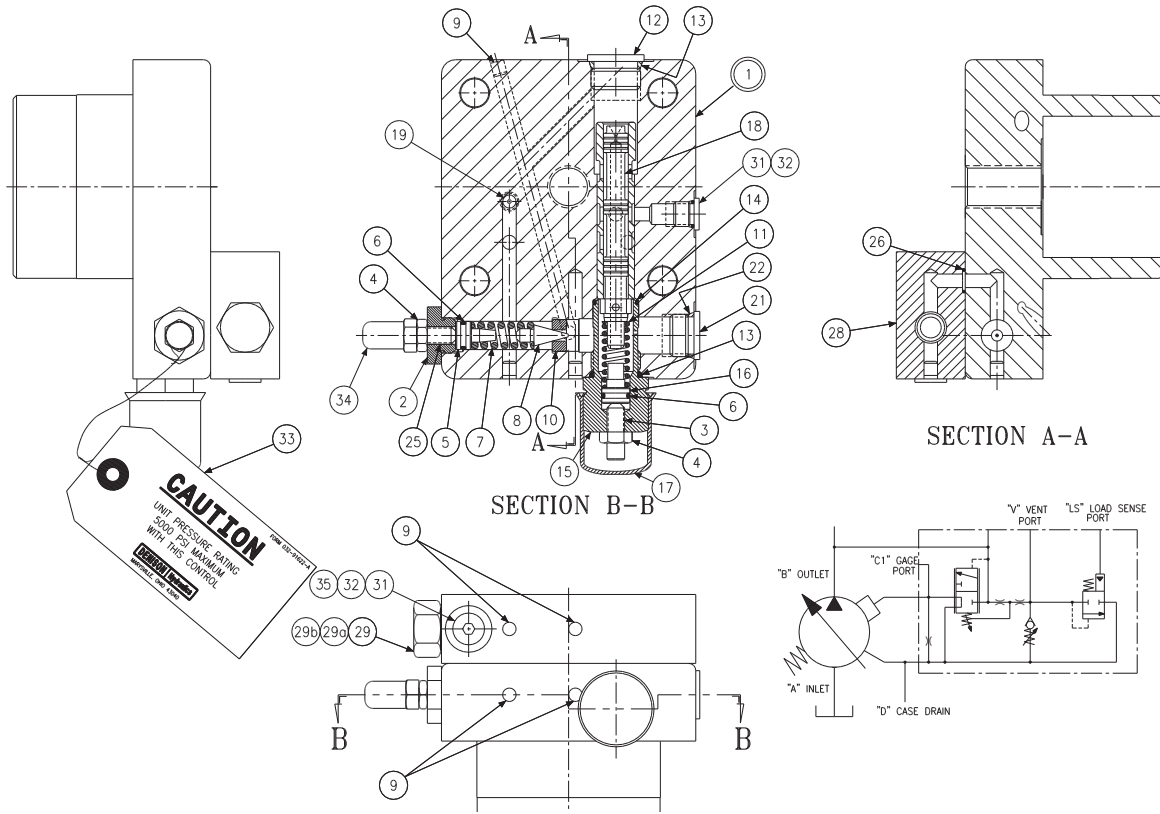

FIGURE 12

load sensing compensator control

**PARTS LIST FOR FIG. 12
LOAD SENSING
COMPENSATOR**

P16 S22-15536

P260 S22-15537

ITEM	DESCRIPTION	P16		P260	
		PART NO.	QTY	PART NO.	QTY
1	Cap-Sleeve Assembly	S22-15143	1	S22-15176	1
2	Adusting Plug	032-91814	1	032-91814	1
3	Socket Setscrew	312-13160	1	312-13160	1
4	Nut, 5/16-24	335-13100	2	335-13100	2
5	Seal Piston	031-59367	1	031-59367	1
6	O-Ring, 90 S-1 ARP 012	691-00012	2	691-00012	2
7	Spring	032-91798	1	032-91798	1
8	Cone	036-12288	1	036-12288	1
9	Avseal Plug	447-00026	5	447-00026	5
10	Seat	036-11692	1	036-11692	1
11	Spring	033-71086	1	033-71086	1
12	Plug, SAE-8, 1/2 BSPP	488-35055	1	447-01008	1
13	O-Ring, 90 S-1 ARP 910	691-00910	2	691-00910	1
14	O-Ring, 90 S-1 ARP 017	691-00017	1	691-00017	1
15	Plug	031-57368	1	031-57368	1
16	Seal Piston	032-91305	1	032-91305	1
17	Cap	449-00612	1	449-00612	1
18	Spool	032-59482	1	032-59482	1
19	Orifice Plug	033-25528	1	033-25528	1
21	Plug, SAE-10, 1/2 BSPP	488-35018	1	447-00032	1
22	O-Ring, 90 S-1 ARP 908	691-00908	1	-	-
25	Soc. Setscrew 5/16-24 x 1-1/4	312-13180	1	312-13180	1
26	O-Ring, 70 S-1 ARP 011	671-00011	2	671-00011	2
28	Body-Valve	032-91620	1	032-91620	1
29	Isolation Valve Cartridge	517-00063	1	517-00063	1
29-A	O-Ring 90 S-1 ARP 017	691-00017	2	691-00017	2
29-B	O-Ring 90 S-1 ARP 015	691-00015	1	691-00015	1
31	Plug, SAE-4, 1/4 BSPP	488-35061	2	447-01004	2
32	O-Ring, 90 S-1 ARP 904	691-00904	2	691-00904	1
33	Tag, Caution	032-91622	1	032-91622	1
34	Nut, Acorn	036-33474	1	036-33474	1
35	Adapter	-	-	032-91507	1

DISASSEMBLY

1. See Figure 12 Back off max. volume screw or handwheel to full displacement. Remove max. volume assembly.
2. Remove bolts holding cap to pump.
3. Remove isolation valve (29) from block (28). Remove plug (15) and attached parts. Remove spring (11) and spool (18).
4. Remove adj. plug (2) and attached parts. Remove seal piston (5). Note: a 10-24 screw may be used to assist in pulling the piston. Remove spring (7) and cone (8).
5. Do not remove sleeve in body (1). Sleeve is pressed into cap and finished to size. If sleeve or cap is worn, replace the cap-sleeve assembly (1).
6. Examine seat (10) for wear. Do not remove unless damaged.

ASSEMBLY

See page 26 for tightening torque on plugs

1. Install Avseal plugs (9) and orifice (19) in body.
2. Press seat (10) into bore squarely against shoulder in bore.
3. Install plug (12) and spool (18) into bore as shown. Install spring (11) over end of spool. Install O-ring (6) on seal piston (16). Lubricate and install into plug (15). Install plug (15) into cap. Install screw (3), nut (4) and cover (17).
4. Install O-ring (6) on seal piston (5).
5. Lubricate O-ring and install cone (8), spring (7) and seal piston into bore in cap (1), being careful that cone enters seat (10). Install remaining parts in body (1).
6. Install O-rings (29-a) and (29-b) on valve (29). Observe that backup ring on inside groove is toward the outside, the one on the middle groove is toward the inside, and the one on the outside groove is toward the outside. Lubricate and install valve (29) in block (28), being careful to avoid damaging the O-rings. Torque to 50 lb.*ft., 67,8 Nm.
7. For the P260 only, install O-ring (32) on adapter (35). Install adapter in block (28). Install plug (31) in adapter (35). For the P16 only, install O-ring (32) on plug (31). Install plug (31) in block (28).
8. Note proper location for cap on pump (pg. 24). Install O-rings on interface between cap and pump control pad. Install O-rings (26) in block (28).
9. Install on pump control pad, guiding the control piston into the bore. Install maximum volume stop parts.
10. Torque mounting bolts to 75 lb.*ft., 102 Nm.

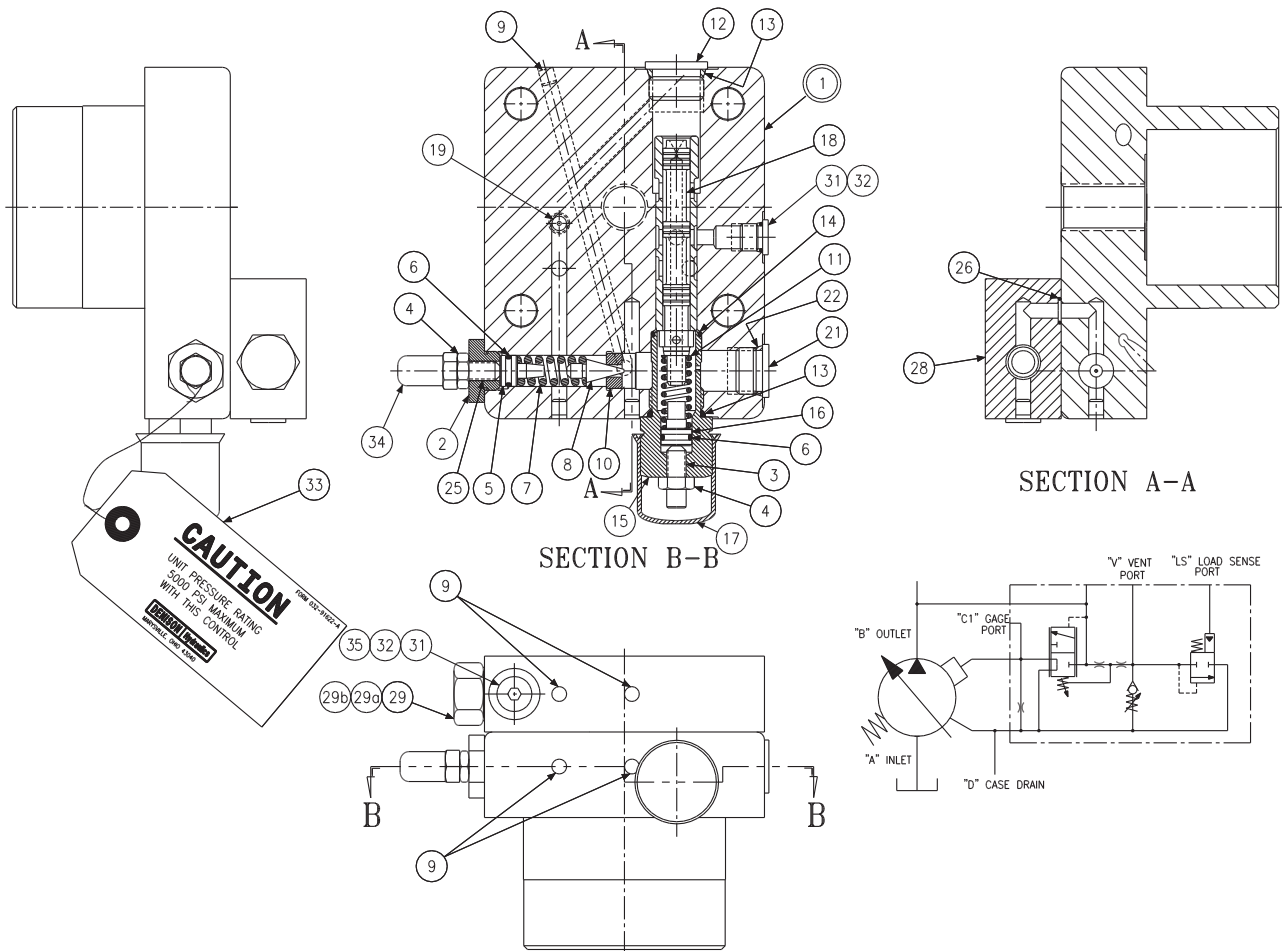

Ref. Figure 12
load sensing compensator control

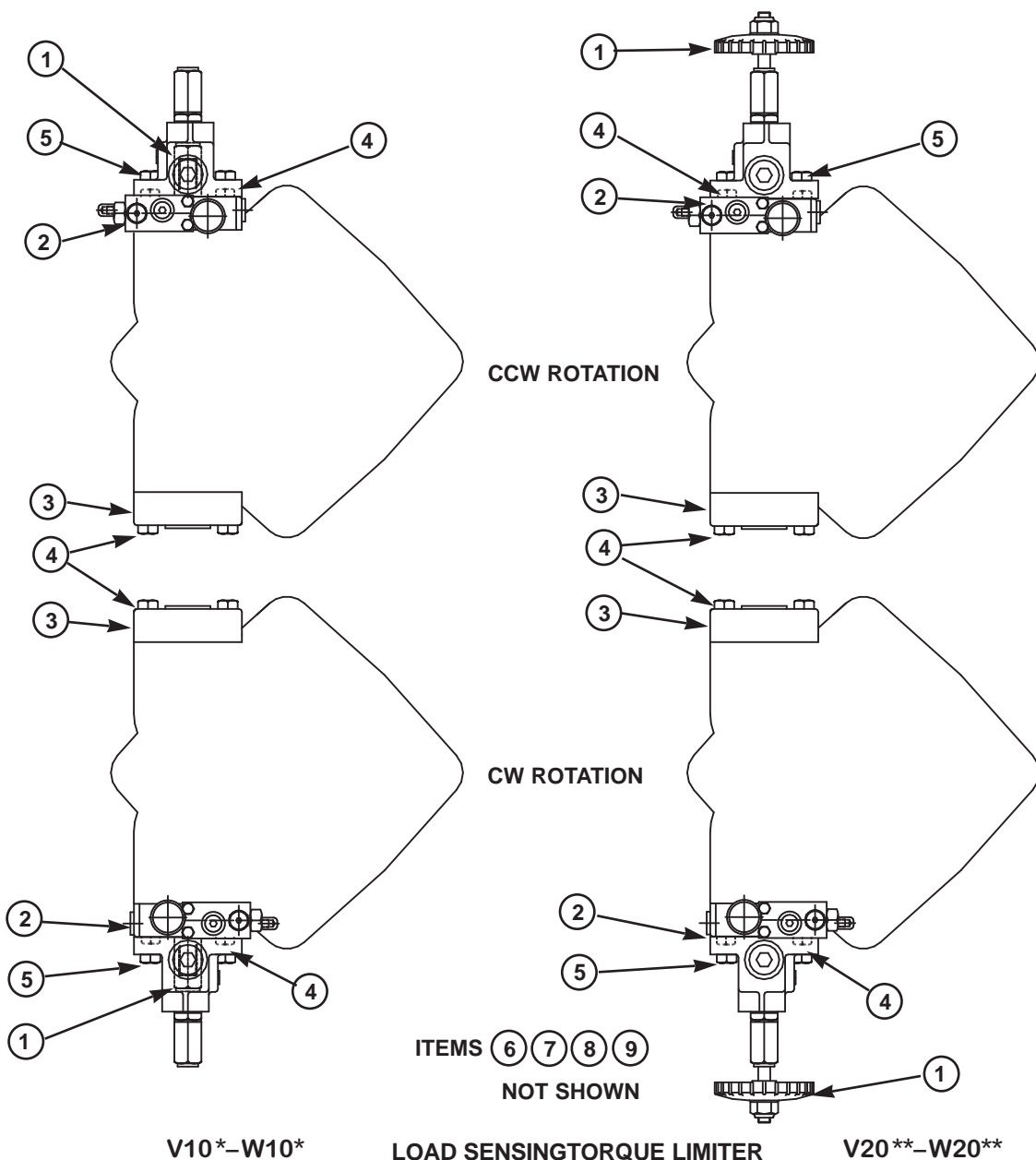

PARTS LIST

load sensing torque limiter

ITEM	DESCRIPTION	P16	P260	QUANTITY			
		PART NO	PART NO.	V10*	W10*	V20**	W20**
1	Maximum Volume Stop (Fig. 7)	S22-12983	S22-12983	1	1	—	—
	Maximum Volume Handwheel (Fig. 8)	S22-12915	S22-12915	—	—	1	1
2	***Low Torque Limiter Load Sensing (Fig. 13)	S22-15790	S22-15802	1	—	—	—
	***High Torque Limiter Load Sensing (Fig. 13)	S22-16191	S22-16192	—	1	—	—
3	Buck Up Cap (Fig. 9)	S22-15653	S22-15653	1	1	1	1
4	Screw-H.H.C., M12 x 60 mm	363-12210	363-12210	6	6	4	4
5	Screw-H.H.C., M12 x 80 mm	363-12225	363-12225	2	2	4	4
6	Control Piston	032-92318	032-92318	1	1	1	1
7	O-Ring, 90 S-1 ARP 013	691-00013	691-00013	2	2	2	2
8	O-Ring, 70 S-1 ARP 152	671-00152	671-00152	2	2	2	2
9	Piston ring	032-91261	032-91261	2	2	2	2

* Also V50, W50

** Also V80, W80

*** Include items 1 (Maximum Volume Stop), 4, 5, 7 and 8

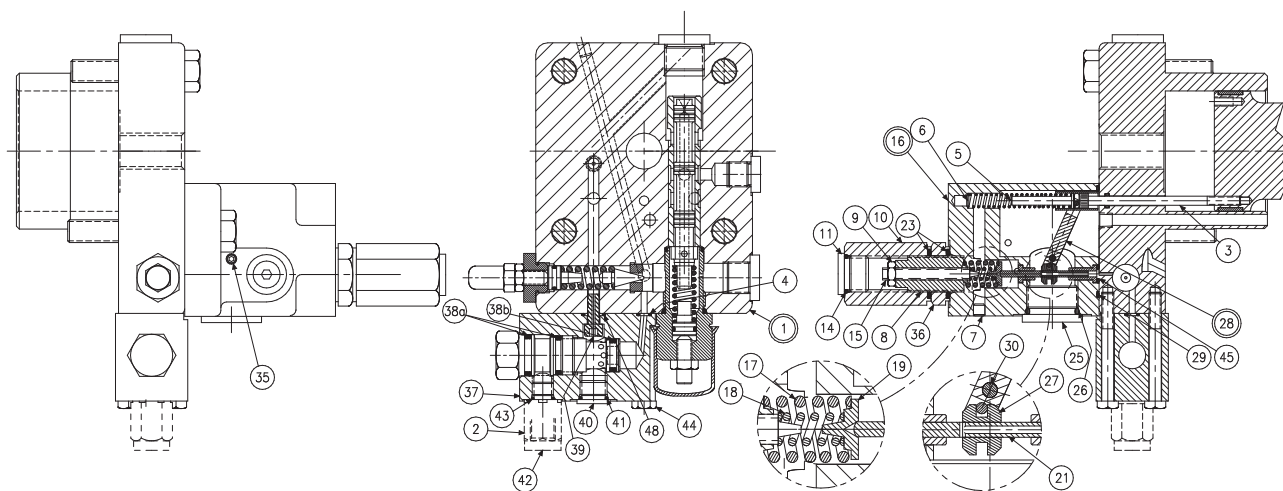

FIGURE 13

Load Sensing Torque Limiter

PARTS LIST FOR FIGURE 13

P16 code V10, V50, S22-15790

P16 code W10, W50, S22-16191

P260 code V10, V50, S22-15802

P260 code W10, W50, S22-16192

ITEM	DESCRIPTION	P16		P260		QTY.	
		PART NO.	PART NO.	V	W		
1	Cap (Figure 14)	S22-15791	S22-15411	1	1		
2	Adapter	-	032-91507	-	1		
3	Screw	032-91461	032-91461	1	1		
4	O-ring, 70 S-1 ARP 008	671-00008	671-00008	1	1		
5	Clevis pin	321-40000	321-40000	1	1		
6	Spring, Compression	032-92100	032-92100	1	1		
7	Plug, Avseal	447-00026	447-00026	1	1		
8	Screw	032-91445	032-91445	1	1		
9	Nut, Hex Jam 1/4-20 UNC	340-00038	340-00038	1	1		
10	Hex Nut, 3/4-16 UNF	032-91449	032-91449	1	1		
11	Plug, SAE-8	488-35018	488-35018	1	1		
14	O-Ring, 90 S-1 ARP 908	691-00908	691-00908	1	1		
15	Screw, Primary Adjust	032-91446	032-91446	1	1		
16	Body assembly	S22-15396	S22-15396	1	1		
17	Outer Spring – J Version	032-91440	032-91440	1	—		
	Outer Spring – K Version	032-91448	032-91448	—	1		
18	Inner Spring – J Version	032-91441	032-91441	1	—		
	Inner Spring – K Version	032-91447	032-91447	—	1		
19	Spring Retainer	032-91819	032-91819	1	1		
21	Spool	032-91438	032-91438	1	1		
23	O-ring, 70 S-1 ARP 118	671-00118	671-00118	2	2		
25	Plug, 12 SAE-12	488-35014	488-35014	1	1		
26	O-Ring, 90 S-1 ARP 912	691-00912	691-00912	1	1		
27	Sleeve	032-91437	032-91437	1	1		
28	Arm assembly	S22-15520	S22-15520	1	1		
29	O-Ring, 70 S-1 ARP 035	671-00035	671-00035	1	1		
30	Dowel Pin, 1/8 Dia. x 1.75 Lg.	324-20828	324-20828	1	1		
35	Screw, SHC 10-32 x 1/4	312-09041	312-09041	2	2		
36	Nut	032-91645	032-91645	1	1		
37	Body, load sense	032-92359	032-92359	1	1		
38	Valve, modulating	517-00063	517-00063	1	1		
38a	O-ring, 90 S-1 ARP 017	691-00017	691-00017	2	2		
38b	O-ring, 90 S-1 ARP 015	691-00015	691-00015	1	1		
39	Screw, special	033-70908	033-70908	1	1		
40	Plug, SAE-6	488-35003	488-35003	1	1		
41	O-ring, 90 S-1 ARP 906	691-00906	691-00906	1	1		
42	Plug, SAE-4, 1/4 BSPP	488-35013	447-01004	1	1		
43	O-ring, 90 S-1 ARP 904	691-00904	691-00904	1	1		
44	Screw, HHC, 1/4-20x2-1/4	306-40187	306-40187	2	2		
45	O-Ring, 70 S-1 ARP 010	671-00010	671-00010	1	1		
48	O-Ring, 70 S-1 ARP 012	671-00012	671-00012	1	1		

DISASSEMBLY

1. **See Figure 13.** Remove 2 screws holding torque limiter body (16) to cap assembly (1).
2. Remove all parts from torque limiter body (16) except pin (30) and arm assembly (28). It is not necessary to remove these parts unless broken or worn. Examine parts for wear or damage.
3. Remove screw (3). Examine head for excessive wear, and body for smooth sealing surface with O-ring.
4. Remove maximum stop handwheel assembly or maximum stop screw assembly.
5. Remove modulating valve (38) from body (37). Remove body (37) from cap assembly (1) Note plug (40) must be removed to remove special screw (39). Remove cap assembly (1).
1. **See Figure 14.** Remove plug (15) and attached parts. Remove spring (11) and spool (18).
2. Remove adj. plug (2) and attached parts. Remove seal piston (5). Note: a 10-24 screw may be used to assist in pulling the piston. Remove spring (7) and cone (8).
3. Do not remove sleeve in body (1). Sleeve is pressed into cap and finished to size. If sleeve or cap is worn, replace the cap-sleeve assembly (1).
4. Examine seat (10) for wear. Do not remove unless damaged.

ASSEMBLY

See page 26 for tightening torque on plugs

1. **See Figure 14.** Install Avseal plug (9) and orifice (19) in body.
2. Press seat (10) into bore squarely against shoulder in bore.
3. Install plug (12) and spool (18) into bore as shown. Install spring (11) over end of spool. Install O-ring (6) on seal piston (16). Lubricate and install into plug (15). Install plug (15) into cap. Install screw (3), nut (4) and cover (17).
4. Install O-ring (6) on seal piston (5).
5. Lubricate O-ring and install cone (8), spring (7) and seal piston into bore in cap (1), being careful that cone enters seat (10). Install remaining parts in body (1)
6. Note proper location for cap on pump (pg.24). Install O-rings on interface between cap and pump control pad
7. Install on pump control pad, guiding the control piston into the bore. Install maximum volume stop or handwheel parts.
8. **See Figure 13.** Install block (37) on cap (1) with O-rings (4) and (48). Use special screw (39) through the block.
7. Install O-rings (38a) and (38b) on valve (38). Observe that backup ring on inside groove is toward the outside, the one on the middle groove is toward the inside, and the one on the outside groove is toward the outside. Lubricate and install valve (38) in block (37), being careful to avoid damaging the O-rings. Torque to 50 lb.*ft., 67,8 Nm.
7. For the P260 only, install O-ring (43) on adapter (2). Install adapter in block (37). Install plug (31) in adapter (35). For the P16 only, install O-ring (43) on plug (42). Install plug (42) in block (37).
- 8.. Apply Loctite 242 on threads of screw (3), lubricate the shank, thread through the cap into the control piston, and torque to 5 lb.*ft., 6,8 Nm
9. Measure height from control cap to top of screw. With control piston at full stroke, dimension must be 1.50 +/- .03 in., 38,1 +/- 0,76 mm.
10. Press dowel (30) into body (16), through the link assembly (28), to 1/4", 6,35 mm below surface. Apply Loctite hydraulic sealant to threads of screws (35) and install over dowel (30).
11. While sleeve (27) is engaged into dowel on link (28), slide spool (21) into bore of body (16), and through sleeve (27). Spool (21) must move freely and easily at all positions of the link (28).
12. Assemble remaining parts per drawing. While spring retainer is engaging clevis pin (5) under dowel of link (28), slide the other opening of spring retainer over the top of the screw (3). Attach body assembly (16) to cap (1) and torque mounting screws to 75 lb.*ft., 102 Nm.

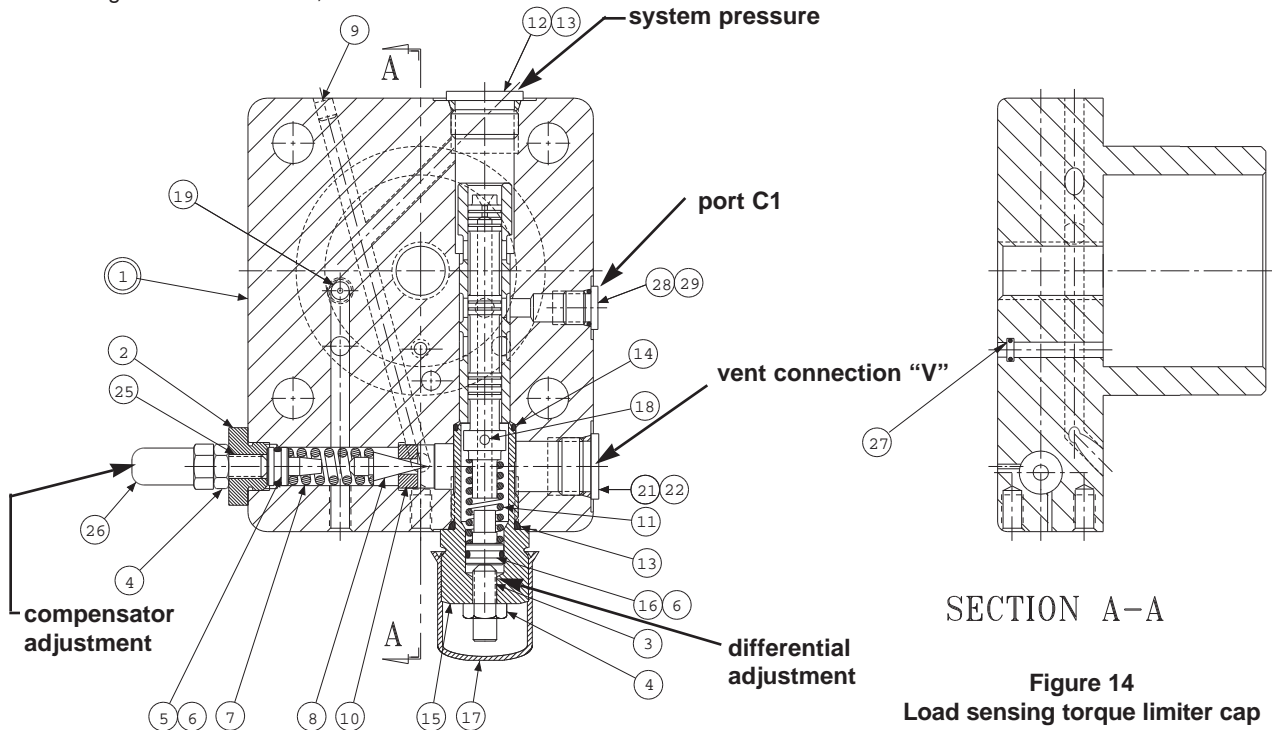
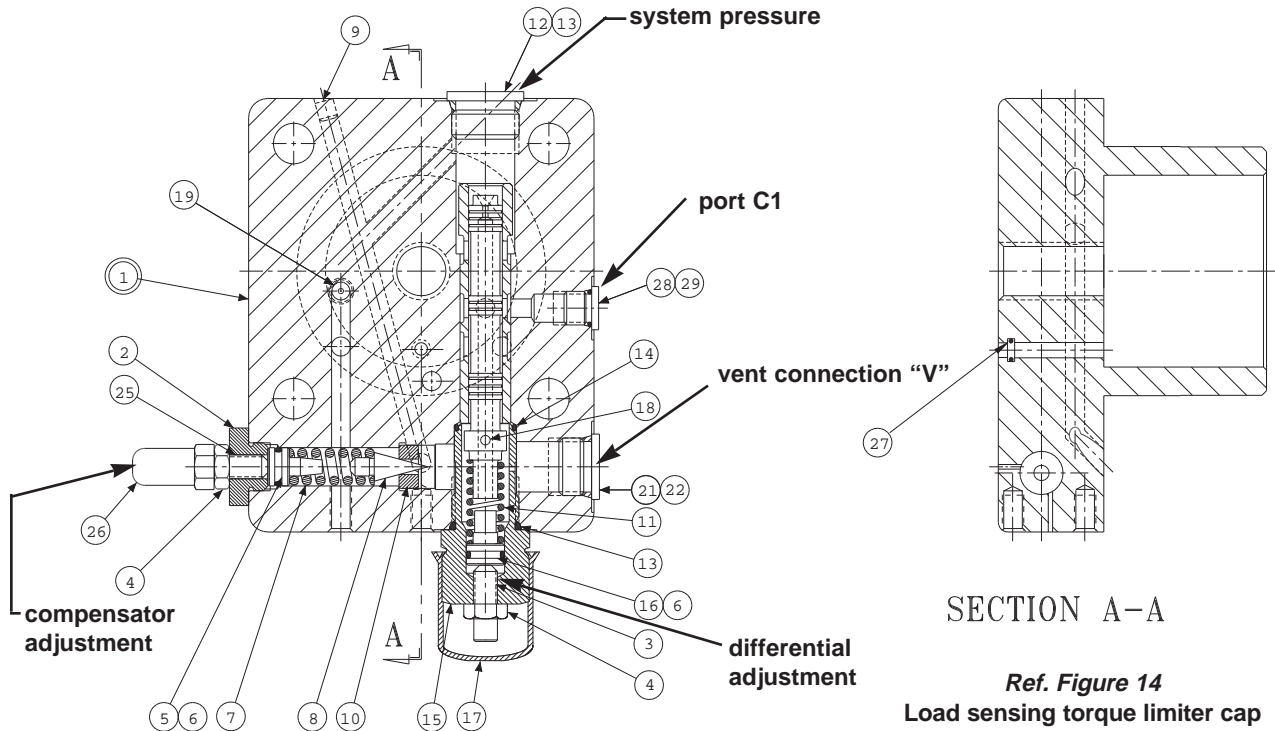

Figure 14
Load sensing torque limiter cap



PARTS LIST FOR FIGURE 14

P16 load sensing torque limiter cap

S22-15791

P260 load sensing torque limiter cap

S22-15411

ITEM	DESCRIPTION	P16		P260	
		PART NO.	QTY.	PART NO.	QTY.
1	Cap-Sleeve Assembly	S22-15792	1	S22-15410	1
2	Adj. Plug	032-91814	1	032-91814	1
3	Soc. Setscrew 5/16-24 x 1	312-13160	1	312-13160	1
4	Nut, 5/16-24	335-13100	2	335-13100	2
5	Seal Piston	031-59367	1	031-59367	1
6	O-Ring, 90 S-1 ARP 012	691-00012	2	691-00012	2
7	Spring	032-91798	1	032-91798	1
8	Cone	036-12288	1	036-12288	1
9	Avseal Plug	447-00026	1	447-00026	1
10	Seat	036-11692	1	036-11692	1
11	Spring	033-71086	1	033-71086	1
12	Plug- SAE-10, 1/2 BSPP	488-35055	1	447-01008	1
13	O-Ring, 90 S-1 ARP 910	691-00910	2	691-00910	1
14	O-Ring, 90 S-1 ARP 017	691-00017	1	691-00017	1
15	Plug	031-57368	1	031-57368	1
16	Seal Piston	032-91305	1	032-91305	1
17	Cap	449-00612	1	449-00612	1
18	Spool	032-59482	1	032-59482	1
19	Orifice	033-25528	1	033-25528	1
21	Plug- SAE-8, 3/8 BSPP	488-35018	1	447-00032	1
22	O-ring, 70 S-1 ARP 908	691-00908	1	-	-
25	Soc. Setscrew 5/16-24 x 1-1/4	312-13180	1	312-13180	1
26	Nut, Acorn 5/16-24	036-33474	1	036-33474	1
27	O-Ring, 70 S-1 ARP 008	671-00008	1	671-00008	1
28	Plug - SAE-4, 1/4 BSPP	488-35061	1	447-01004	1
29	O-ring 90 S-1 ARP 904	691-00904	1	-	-

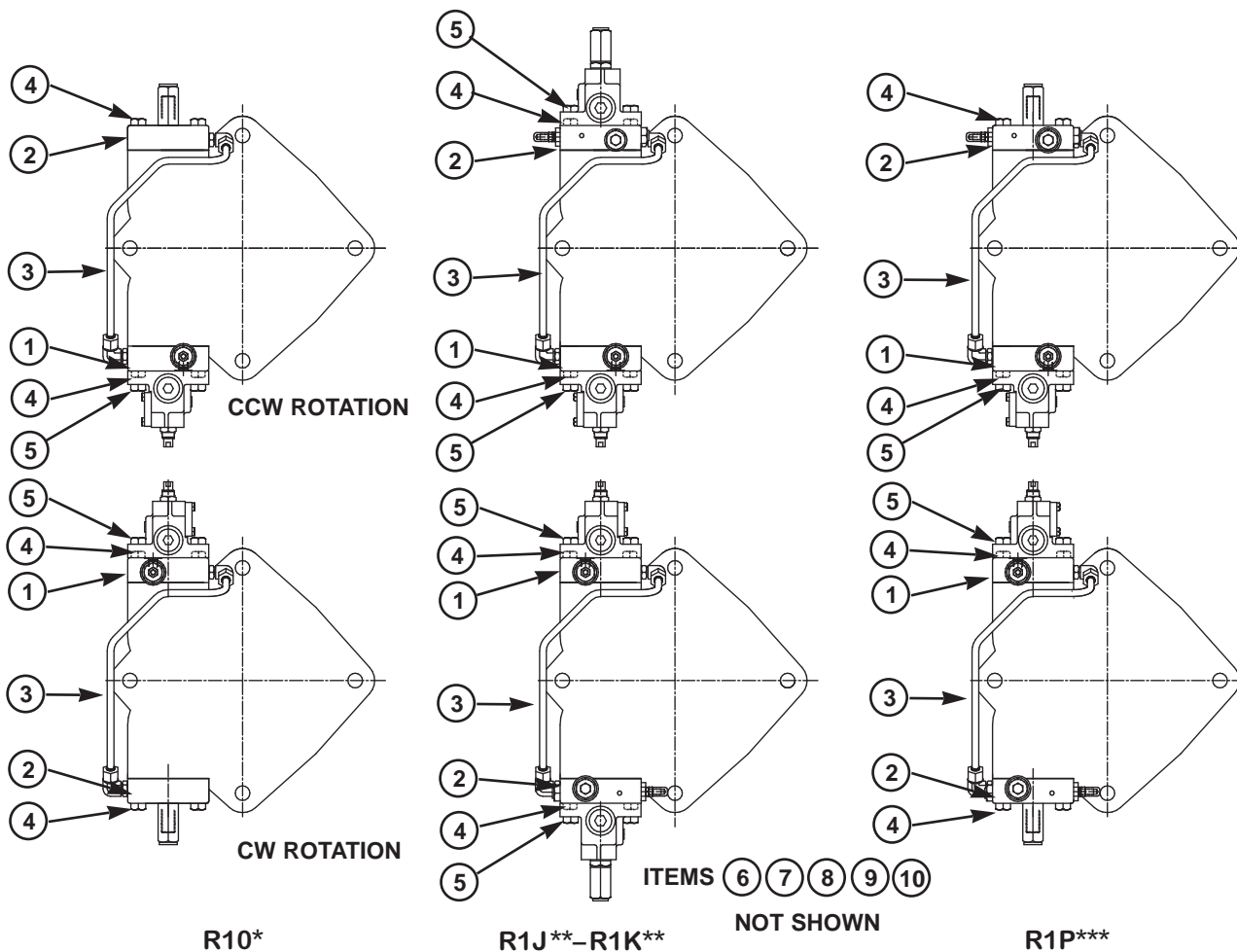

PARTS LIST

rotary servo

ITEM	DESCRIPTION	P16	P260	QUANTITY			
		PART NO.	PART NO.	R10*	R1J**	R1K**	R1P***
1	#Rotary Servo (Fig. 15)	S22-16005	S22-16006	1	1	1	1
2	#Control Cap (Fig.26)	S22-15256	S22-15272	1	—	—	—
	#Low Torque Override (Fig. 29)	S22-16009	S22-16010	—	1	—	—
	#High Torque Override (Fig. 29)	S22-16011	S22-16012	—	—	1	—
	#Compensator Override (Fig. 27)	S22-16007	S22-16008	—	—	—	1
3	Tube Assembly (Fig. 24, 25)	P22-15981	P22-15998	1	1	1	1
4	Screw-H.H.C., M12 x 60 mm	363-12210	363-12210	6	4	4	6
5	Screw-H.H.C., M12 x 80 mm	363-12225	363-12225	2	4	4	2
6	Control Piston	032-91785	032-91785	1	1	1	1
7	O-Ring, 90 S-1 ARP 013	691-00013	691-00013	2	2	2	2
8	O-Ring, 70 S-1 ARP 152	671-00152	671-00152	2	2	2	2
9	Piston Ring	032-91261	032-91261	1	1	1	1
10	Piston Ring	032-91811	032-91811	1	1	1	1

*Also R50

**Also R5J, R5K

***Also R5P

#Includes items 4, 5, 7 and 8

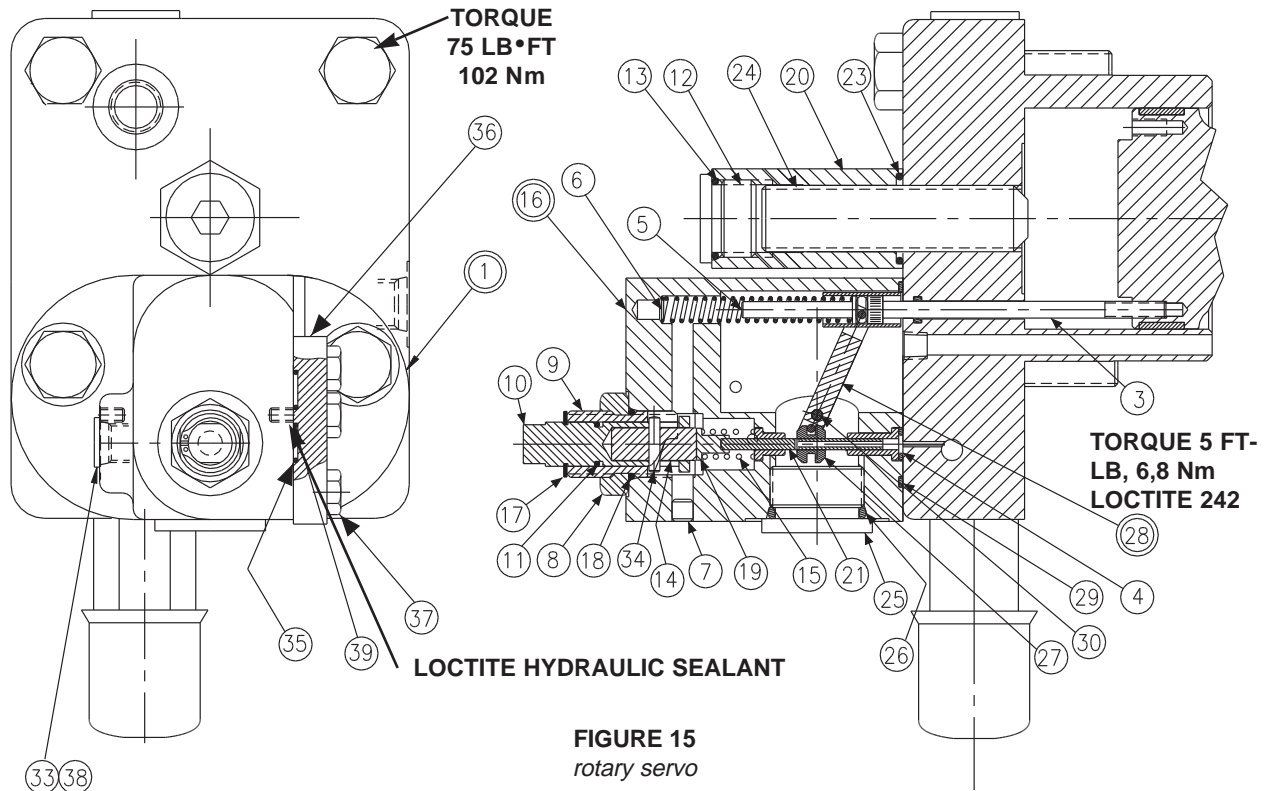

FIGURE 15
rotary servo

PARTS LIST FOR FIGURE 15
ROTARY SERVO

P16 S22-16005
P260 S22-16006

ITEM	DESCRIPTION	P16		P260	
		PART NO.	QTY.	PART NO.	QTY.
1	Cap (Figure 16)	S22-15900	1	S22-15901	1
3	Screw	032-91461	1	032-91461	1
4	O-Ring, 70 S-1 ARP 010	671-00010	1	671-00010	1
5	Pin, Clevis	321-40000	1	321-40000	1
6	Spring, Compression	032-92100	1	032-92100	1
7	Plug, Avseal	447-00026	1	447-00026	1
8	Locknut	492-15116	1	492-15116	1
9	Cam	032-91515	1	032-91515	1
10	Shaft	032-91514	1	032-91514	1
11	O-Ring, 90 S-1 ARP 012	691-00012	1	691-00012	1
12	Plug, 10HP5N-S	488-35055	1	488-35055	1
13	O-Ring, 90 S-1 ARP 910	691-00910	1	691-00910	1
14	Slide Pin	032-91513	1	032-91513	1
15	Spring	225-92105	1	225-92105	1
16	Body	S22-15393	1	S22-15393	1
17	Retaining Ring	356-31050	1	356-31050	1
18	O-Ring, 90 S-1 ARP 908	691-00908	1	691-00908	1
19	Spring Retainer	032-91516	1	032-91516	1
20	Nut, 3/4-10	031-91049	1	031-91049	1
21	Spool	032-91438	1	032-91438	1
23	O-Ring, 70 S-1 ARP 118	671-00118	1	671-00118	1
24	Soc. Setscrew, 3/4-10 x 3	311-26320	1	311-26320	1
25	Plug, 12 HP5N-S	488-35014	1	488-35014	1
26	O-Ring, 90 S-1 ARP 912	691-00912	1	691-00912	1
27	Sleeve	032-91437	1	032-91437	1
28	Arm assembly	S22-15520	1	S22-15520	1
29	O-Ring, 70 S-1 ARP 035	671-00035	1	671-00035	1
30	Dowel Pin, 1/8 Dia x 1.75 Lg.	324-20828	1	324-20828	1
33	O-Ring, 70 S-1 ARP 904	671-00904	1	671-00904	1
34	Dowel Pin, 1/8 x 5/8	324-20810	1	324-20810	1
35	O-Ring, 70 S-1 ARP 011	671-00011	2	671-00011	2
36	Plate	032-91510	1	032-91510	1
37	Screw, HHC, 1/4-20 x 3/4	306-40142	3	306-40142	3
38	Plug, SAE-4	488-35061	1	488-35061	1
39	Screw, SHC 10-32 x 1/4	312-09041	2	312-09041	2

DISASSEMBLY

1. See Figure 15. Remove 2 screws holding body (16) to cap assembly (1).
2. Remove all parts from body (16) except pin (30) and arm assembly (28). It is not necessary to remove these parts unless broken or worn. Examine parts for wear or damage.
3. Remove screw (3). Examine head for excessive wear, and body for smooth sealing surface with O-ring.
4. See Figure 16. Remove tube lines to cap assembly.
5. Remove screws holding cap assembly to pump body.
6. Remove cap assembly (1). Remove plug (3) with attached parts. Remove spring (8) and spool (4).
7. Do not remove sleeve in body (1). Sleeve is pressed into cap and finished to size. If sleeve or cap is worn, replace the cap-sleeve assembly (1).
8. Remove screw (14) and nut (15). Push a rod through the cap to remove the retainer (12).

ASSEMBLY

See page 26 for tightening torque on plugs

1. See Figure 16. Install Avseal plug (6) in cap.
2. Install spool (4) into bore as shown. Install spring (8) over end of spool.
3. Install O-ring (13) on spring retainer (12). Install retainer (12), screw (14) and nut (15) in plug (3).
4. Install O-rings (7) and (16) on plug (3). Install plugs (3) and (9) in body (1). Install orifice (20) and plugs (10). Torque plugs. Install O-ring (5) in cap.
5. Turn screw (14) in until spring retainer (12) contacts spring (8). Turn an additional 1-1/2 turns and lock in position.
6. Note proper location for control on pump (pg. 24). Install O-rings on interface between cap and pump control pad. Install cap on pump control pad, guiding the control piston into the bore.
7. Torque two assembly bolts to 75 lb.·ft., 102 N m.
8. See Figure 15. Apply Loctite 242 on threads of screw (3), lubricate the shank, thread through the cap into the control piston, and torque to 5 lb.·ft., 6,78 N m.
9. Install minimum stop screw (24) and turn clockwise to stroke pump to full stroke. Measure height from control cap to top of screw (3). With control piston at full stroke, dimension must be .45 +/- .03 in., 11,4 +/- 0,76 mm. Back out minimum stop screw (24) till there is no contact with control piston.
10. Press dowel (30) into body (16), through the link (28), to 1/4 in., 6,35 mm below surface. Apply Loctite hydraulic sealant to threads of screws (39) and install over dowel (30).
11. Press spool (21) into retainer (19). Caution: do not use excessive force.
12. While sleeve (27) is engaged into dowel on link (28), slide above spool assembly with spring (15) into bore of body (16), and through sleeve (27). Spool (21) must move freely and easily at all positions of the link (28).
13. Press dowel (34) through slide pin (14), while inside shaft (10). Dowel (34) must evenly extend from both sides of slide pin (14).
14. Assemble all other components into body (16) per Figure 18. Torque plug (12)
15. While spring retainer is engaging screw (5) under dowel of link (28), slide the other opening of spring retainer over the top of the screw (3). Attach body assembly (16) to cap (1) with two screws and torque to 75 lb.·ft., 103 N m.
16. Install tubing assembly (Figure 24, 25).

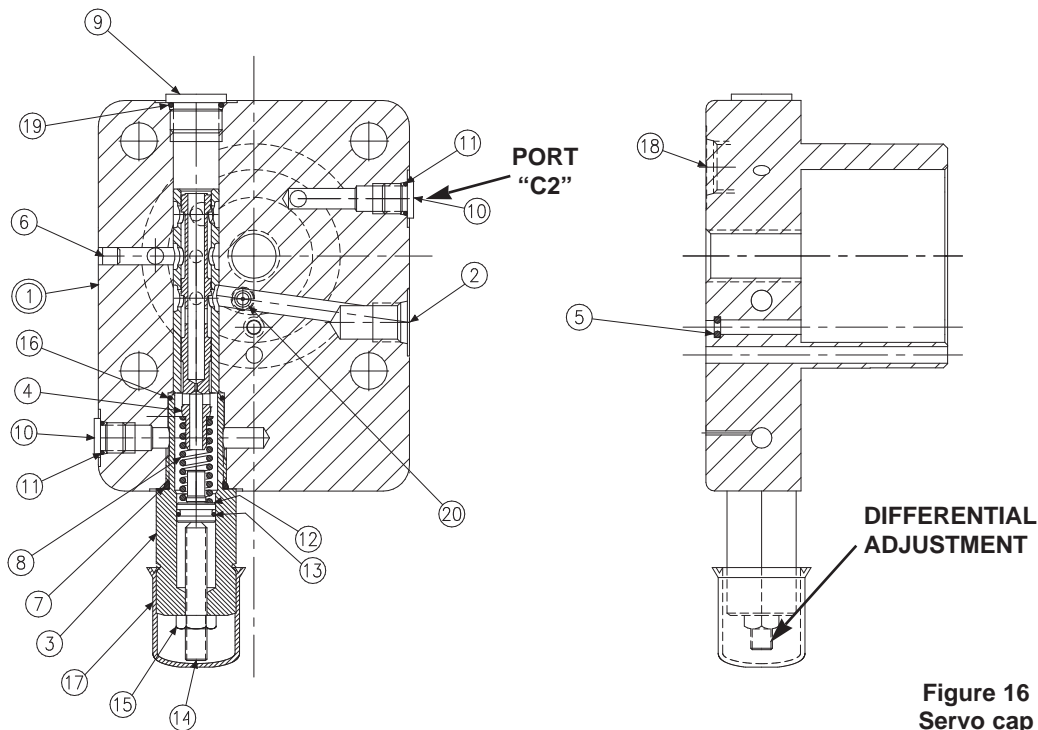
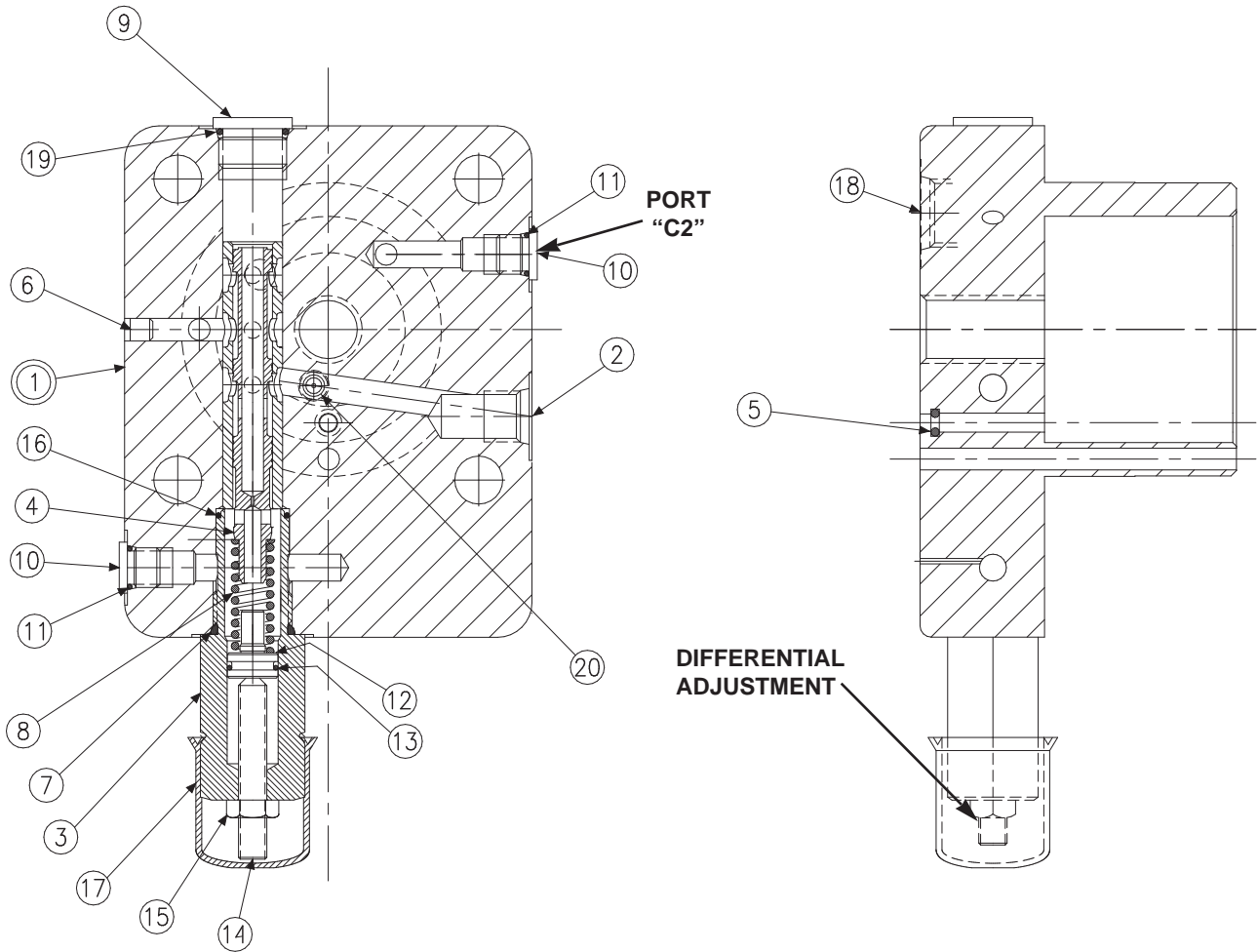

Figure 16
Servo cap



Ref. Figure 16
Servo cap

PARTS LIST FOR FIGURE 16

P16 servo cap S22-15900
P260 servo cap S22-15901

ITEM	DESCRIPTION	P16		P260	
		PART NO.	QTY	PART NO.	QTY.
1	Cap/Sleeve	S22-15914	1	S22-15915	1
2	Plug	449-00015	2	449-00599	2
3	Plug	032-91861	1	032-91861	1
4	Spool	032-92409	1	032-92409	1
5	O-Ring, 70 S-1 ARP 008	671-00008	1	671-00008	1
6	Avseal Plug	447-00026	1	447-00026	1
7	O-Ring, 90 S-1 ARP 910	691-00910	2	691-00910	1
8	Spring	032-92098	1	032-92098	1
9	Plug, SAE-10, 1/2 BSPP	488-35018	1	447-01008	1
10	Plug, SAE-4, 1/4 BSPP	488-35061	1	447-01004	1
11	O-ring, 90 S-1 ARP 904	691-00904	1	-	-
12	Spring retainer	032-92550	1	032-92550	1
13	O-Ring, 90 S-1 ARP 013	691-00013	1	691-00013	1
14	Screw, 5/16 -24 x 2	312-35062	1	312-35062	1
15	Nut, 5/16-24	335-13100	1	335-13100	1
16	O-Ring, 90 S-1 ARP 017	691-00017	1	691-00017	1
17	Cap	449-00612	1	449-00612	1
18	Plug	449-00016	1	449-00016	1
19	O-ring, 90 S-1 ARP 908	691-00908	1	691-00908	1
20	Orifice	033-25528	1	033-25528	1

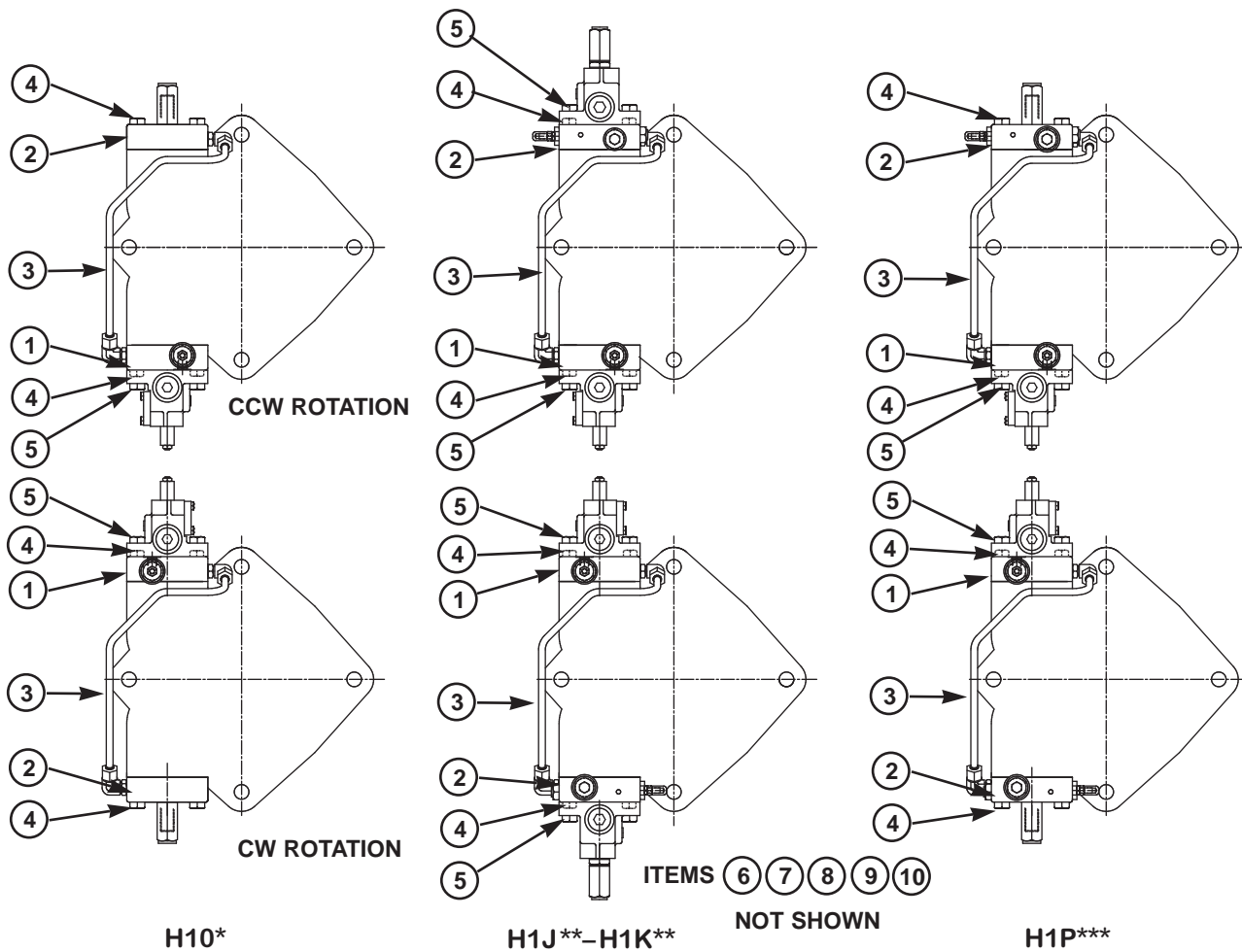

PARTS LIST
hydraulic stroker

ITEM	DESCRIPTION	P16	P260	QUANTITY			
		PART NO.	PART NO.	H10*	H1J**	H1K**	H1P***
1	#Hydraulic Stroker (Fig. 17)	S22-16003	S22-16004	1	1	1	1
2	#Control Cap (Fig. 26)	S22-15256	S22-15272	1	—	—	—
	#Low Torque Override (Fig. 29)	S22-16009	S22-16010	—	1	—	—
	#High Torque Override (Fig. 29)	S22-16011	S22-16012	—	—	1	—
	#Compensator Override (Fig. 27)	S22-16007	S22-16008	—	—	—	1
3	Tube Assembly (Fig. 24, 25)	P22-15981	P22-15998	1	1	1	1
4	Screw-H.H.C., M12 x 60 mm	363-12210	363-12210	6	4	4	6
5	Screw-H.H.C., M12 x 80 mm	363-12225	363-12225	2	4	4	2
6	Control Piston	032-91785	032-91785	1	1	1	1
7	O-Ring, 90 S-1 ARP 013	691-00013	691-00013	2	2	2	2
8	O-Ring, 70 S-1 ARP 152	671-00152	671-00152	2	2	2	2
9	Piston Ring	032-91261	032-91261	1	1	1	1
10	Piston Ring	032-91811	032-91811	1	1	1	1

*Also H50

**Also H5J, H5K

***Also H5P

#Includes items 4, 5, 7 and 8

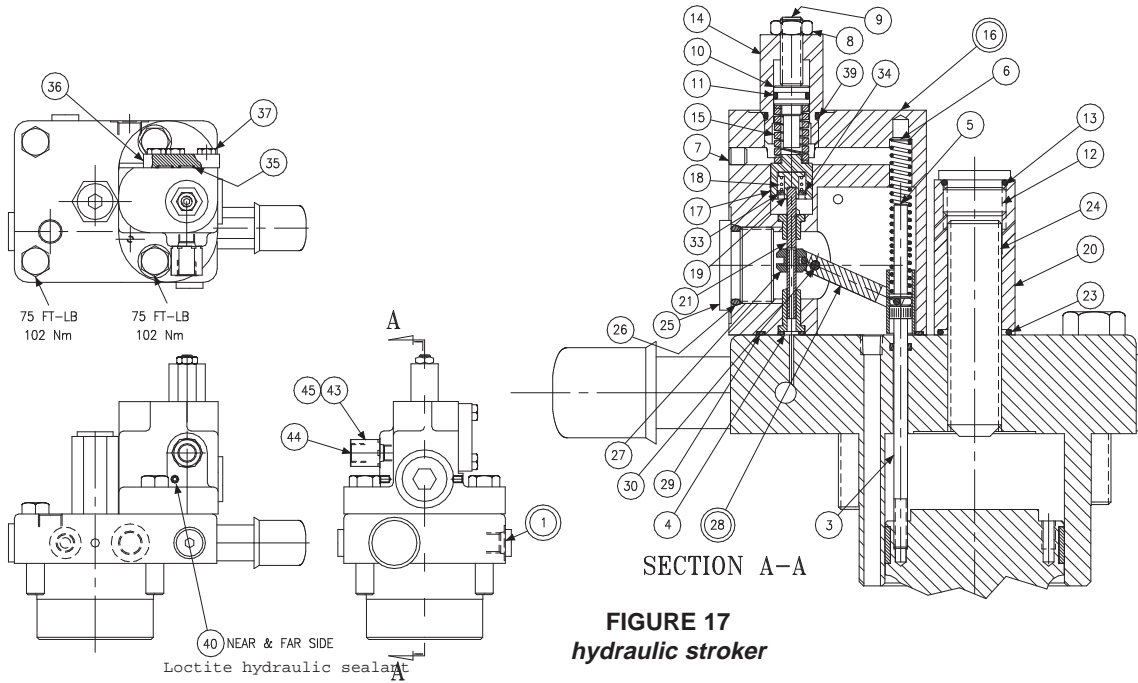

FIGURE 17
hydraulic stroker

PARTS LIST FOR FIG. 17
P16 hydraulic stroker S22-16003
P260 hydraulic stroker S22-16004

ITEM	DESCRIPTION	P16		P260	
		PART NO.	QTY.	PART NO.	QTY.
1	Cap (Figure 16)	S22-15900	1	S22-15901	1
3	Screw	032-91461	1	032-91461	1
4	O-Ring, 70 S-1 ARP 010	671-00010	1	671-00010	1
5	Clevis pin	321-40000	1	321-40000	1
6	Spring, Compression	032-92100	1	032-92100	1
7	Plug, Avseal	447-00026	1	447-00026	1
8	Nut, 5/16-24	335-13100	1	335-13100	1
9	Soc. Setscrew, 5/16-24 x 1-1/4	312-13180	1	312-13180	1
10	Seal Piston	032-91918	1	032-91918	1
11	O-Ring, 90 S-1 ARP 012	691-00012	1	691-00012	1
12	Plug, 10HP5N-S	488-35055	1	488-35055	1
13	O-Ring, 90 S-1 ARP 910	691-00910	1	691-00910	1
14	Spring Cap	032-91511	1	032-91511	1
15	Spring	225-92101	1	225-92101	1
16	Body	S22-15393	1	S22-15393	1
17	Spool	032-91512	1	032-91512	1
18	Spring	225-92109	1	225-92109	1
19	Spring Retainer	032-91516	1	032-91516	1
20	Nut, 3/4-10	031-91049	1	031-91049	1
21	Spool	032-91438	1	032-91438	1
23	O-Ring,70 S-1 ARP 118	671-00118	1	671-00118	1
24	Soc. Setscrew, 3/4-10 x 3	311-26320	1	311-26320	1
25	Plug, SAE-12	488-35014	1	488-35014	1
26	O-Ring, 90 S-1 ARP 912	691-00912	1	691-00912	1
27	Sleeve	032-91437	1	032-91437	1
28	Arm assembly	S22-15520	1	S22-15520	1
29	O-Ring, 70 S-1 ARP 035	671-00035	1	671-00035	1
30	Dowel Pin, 1/8 Dia x 1.75 Lg.	324-20828	1	324-20828	1
33	Retaining. Ring	356-30037	1	356-30037	1
34	Washer	032-91517	1	032-91517	1
35	O-Ring, 70 S-1 ARP 011	671-00011	2	671-00011	2
36	Plate	032-91510	1	032-91510	1
37	Screw, HHC,1/4-20 x 3/4	306-40142	3	306-40142	3
39	O-Ring, 90 S-1 ARP 908	691-00908	1	691-00908	1
40	Screw, SHC 10-32 x 1/4	312-09041	2	312-09041	2
43	Fitting	-	-	032-91507	1
44	Seal	-	-	449-00603	1
45	O-ring, 90 S-1 ARP 904	-	-	691-00904	1

DISASSEMBLY

1. See figure 17. Remove 2 screws holding body (16) to cap assembly (1).
2. Remove all parts from body (16) except pin (30) and arm assembly (28). It is not necessary to remove these parts unless broken or worn. Examine parts for wear or damage.
3. Remove screw (3). Examine head for excessive wear, and body for smooth sealing surface with O-ring.
4. See figure 16. Remove tube lines to cap assembly.
5. Remove screws holding cap assembly to pump body.
6. Remove cap assembly (1). Remove plug (3) with attached parts. Remove spring (12) and spool (4).
7. Do not remove sleeve in body (1). Sleeve is pressed into cap and finished to size. If sleeve or cap is worn, replace the cap-sleeve assembly (1).
8. Remove screw (14) and nut (15). Push a rod through the cap to remove the retainer (12).

ASSEMBLY

See page 26 for tightening torque on plugs

1. See figure 16. Install Avseal plug (6) in cap.
2. Install spool (4) into bore as shown. Install spring (8) over end of spool.
3. Install O-ring (13) on spring retainer (12). Install retainer (12), screw (14), and nut (15) in plug (3).
4. Install O-rings (7) and (16) on plug (3). Install plugs (3) and (9) in body (1). Install orifice (20) and plugs (10). Torque plugs. Install O-ring (5) in cap.
5. Turn screw (14) in until spring retainer (12) contacts spring (8). Turn an additional 1-1/2 turns and lock in position.
6. Note proper location for control on pump (pg. 24). Install O-rings on interface between cap and pump control pad. Install cap on pump control pad, guiding the control piston into the bore.
7. Torque two assembly bolts to 75 lb.·ft., 102 Nm.
8. See figure 17. Apply Loctite 242 on threads of screw (3), lubricate the shank, thread through the cap into the control piston, and torque to 5 lb.·ft., 6,78 Nm.
9. Install minimum stop screw (24) and turn clockwise to stroke pump to full volume. Measure height from control cap to top of screw (3). With control piston at full stroke, dimension must be .45 +/- .03 in., 11,4 +/- 0,76 mm. Back out minimum stop screw (24) till there is no contact with control piston.
10. Press dowel (30) into body (16), through the link (28), to 1/4", 6,35 mm below surface. Apply Loctite hydraulic sealant to threads of screws (40) and install over dowel (30).
11. Press spool (21) into retainer (19). Caution: do not use excessive force. Place spool/retainer assembly into spool (17) with spring (18) and washer (34). Secure with retaining ring (33).
12. While sleeve (27) is engaged into dowel on link (28), slide above spool assembly into bore of body (16), and through sleeve (27). Spool (21) must move freely and easily at all positions of the link (28).
13. Assemble all other components into body (16) per above drawing. Torque plug (12).
14. While spring retainer is engaging clevis pin (5) under dowel of link (28), slide the other opening of spring retainer over the top of the screw (3). Attach body assembly (16) to cap (1) with two screws and torque to 75 lb.·ft., 102 Nm.
15. Install tubing assembly (Figure 24, 25).

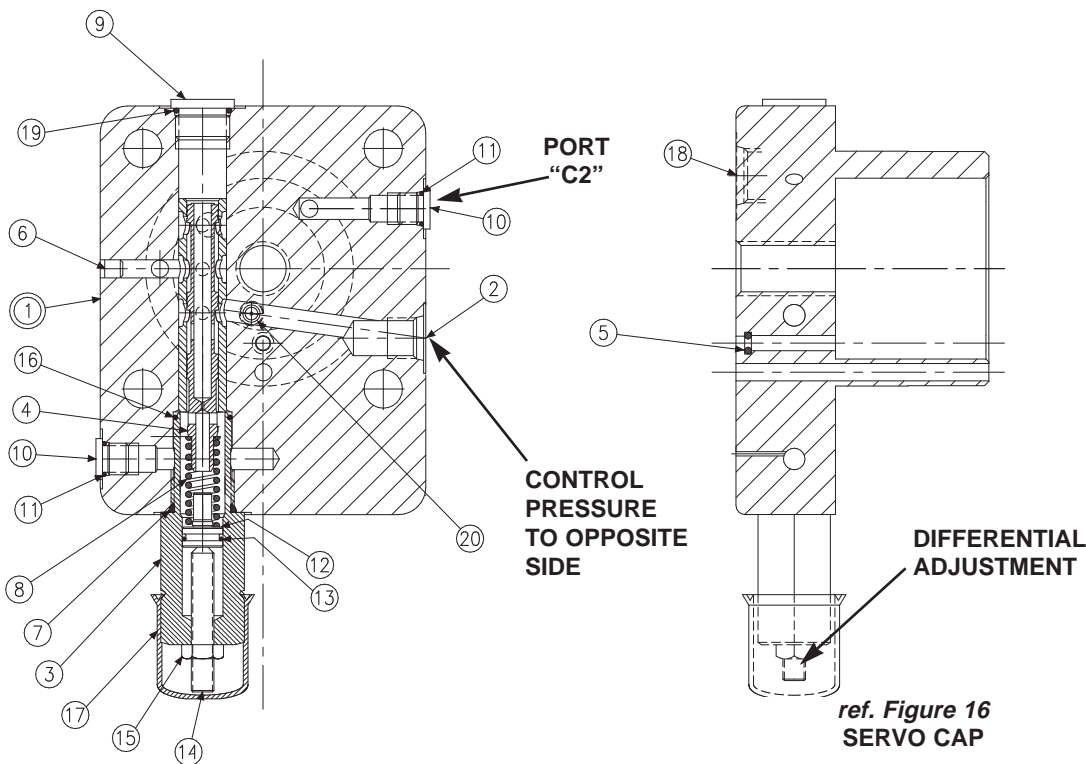

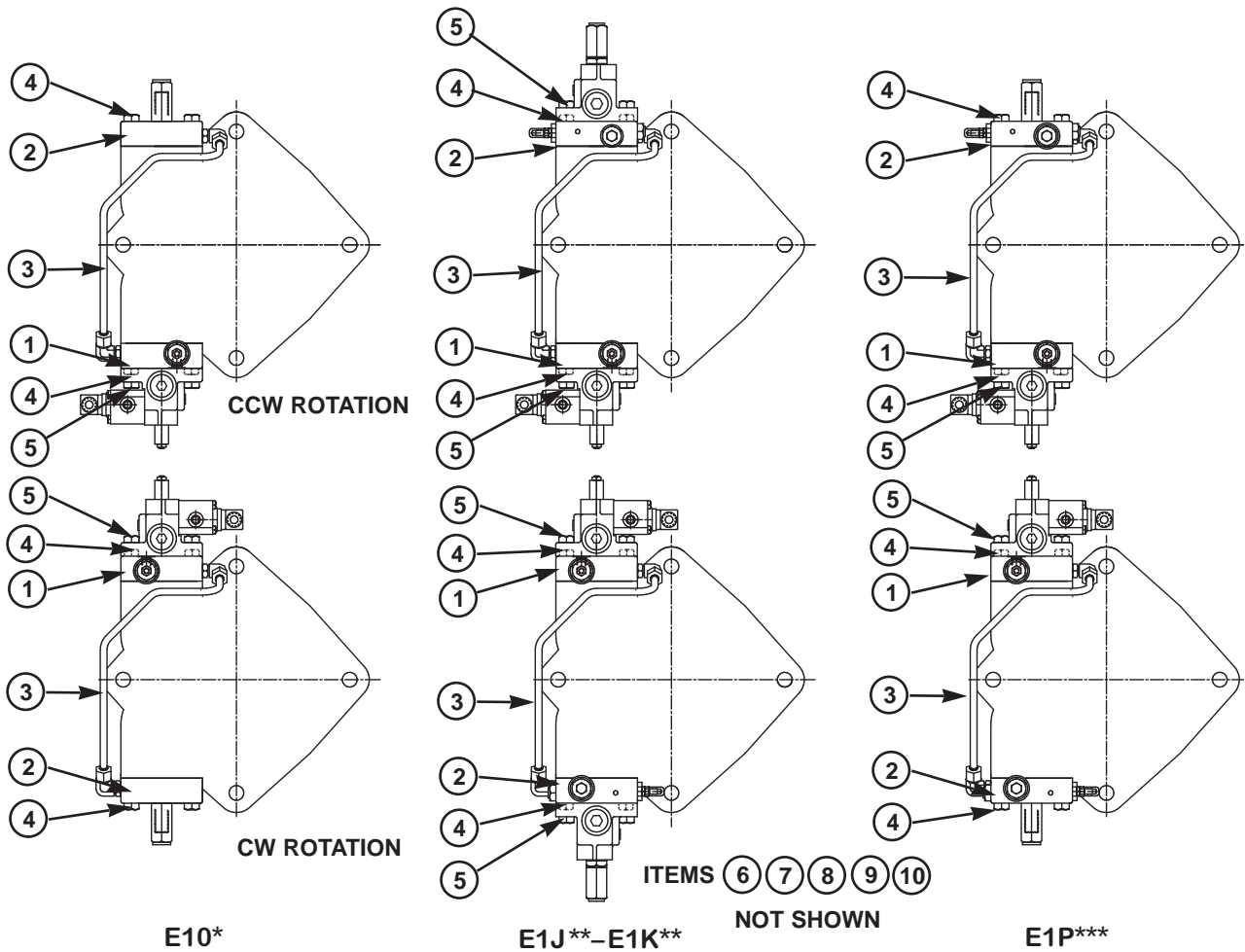

PARTS LIST
electrohydraulic stroker

ITEM	DESCRIPTION	P16		P260		QUANTITY			
		PART NO.	PART NO.	PART NO.	PART NO.	E10*	E1J**	E1K**	E1P***
1	#Electrohydraulic Stroker (Fig. 18)	S22-16001	S22-16002	1	1	1	1	1	1
2	#Control Cap (Fig. 26)	S22-15256	S22-15272	1	—	—	—	—	—
	#Low Torque Override (Fig. 29)	S22-16009	S22-16010	—	1	—	—	—	—
	#High Torque Override (Fig. 29)	S22-16011	S22-16012	—	—	1	—	—	—
	#Compensator Override (Fig. 27)	S22-16007	S22-16008	—	—	—	—	—	1
3	Tube Assembly (Fig. 24, 25)	P22-15981	P22-15998	1	1	1	1	1	1
4	Screw-H.H.C., M12 x 60 mm	363-12210	363-12210	6	4	4	6	6	6
5	Screw-H.H.C., M12 x 80 mm	363-12225	363-12225	2	4	4	2	2	2
6	Control Piston	032-91785	032-91785	1	1	1	1	1	1
7	O-Ring, 90 S-1 ARP 013	691-00013	691-00013	2	2	2	2	2	2
8	O-Ring, 70 S-1 ARP 152	671-00152	671-00152	2	2	2	2	2	2
9	Piston Ring	032-91261	032-91261	1	1	1	1	1	1
10	Piston Ring	032-91811	032-91811	1	1	1	1	1	1

*Also E50

**Also E5J, E5K

***Also E5P

#Includes items 4, 5, 7 and 8

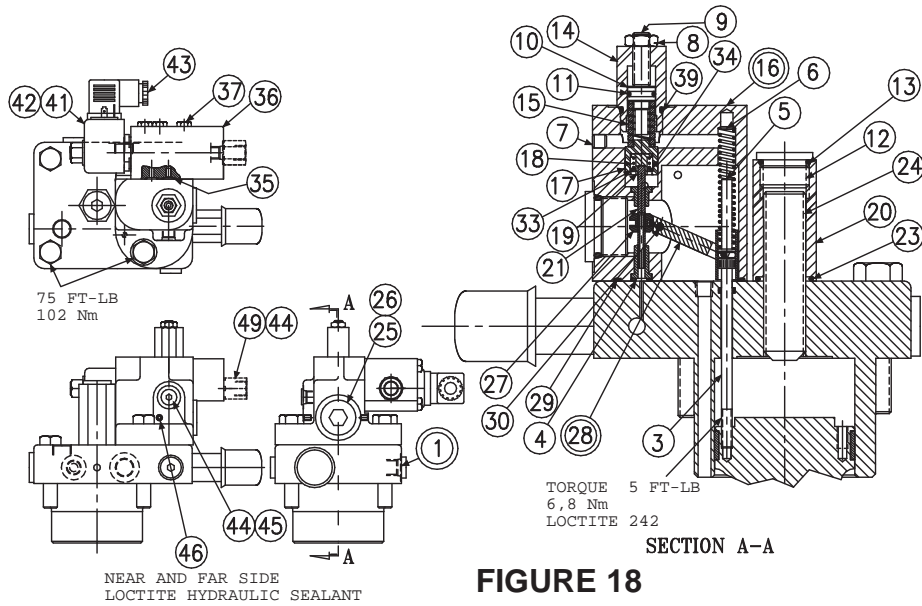

FIGURE 18
Electrohydraulic Stroker

PARTS LIST FOR FIGURE 18

P16 electrohydraulic stroker
S22-16001
P260 electrohydraulic stroker
S22-16002

ITEM	DESCRIPTION	P16		P260	
		PART NO.	QTY.	PART NO.	QTY.
1	Cap (Figure 16)	S22-15900	1	S22-15901	1
3	Screw	032-91461	1	032-91461	1
4	O-Ring, 70 S-1 ARP 010	671-00010	1	671-00010	1
5	Clevis pin	321-40000	1	321-40000	1
6	Spring, Compression	032-92100	1	032-92100	1
7	Plug, Avseal	447-00026	1	447-00026	1
8	Nut, 5/16-24	335-13100	1	335-13100	1
9	Soc. Setscrew, 5/16-24 x 1-1/4	312-13180	1	312-13180	1
10	Seal Piston	032-91918	1	032-91918	1
11	O-Ring, 90 S-1 ARP 012	691-00012	1	691-00012	1
12	Plug, SAE-10	488-35055	1	488-35055	1
13	O-Ring, 90 S-1 ARP 910	691-00910	1	691-00910	1
14	Spring Cap	032-91511	1	032-91511	1
15	Spring	225-92101	1	225-92101	1
16	Body	S22-15393	1	S22-15393	1
17	Spool	032-91512	1	032-91512	1
18	Spring	225-92109	1	225-92109	1
19	Spring Retainer	032-91516	1	032-91516	1
20	Nut, 3/4-10	031-91049	1	031-91049	1
21	Spool	032-91438	1	032-91438	1
23	O-Ring, 70 S-1 ARP 118	671-00118	1	671-00118	1
24	Socket Setscrew, 3/4-10 x 3	311-26320	1	311-26320	1
25	Plug, SAE-12	488-35014	1	488-35014	1
26	O-Ring, 90 S-1 ARP 912	691-00912	1	691-00912	1
27	Sleeve	032-91437	1	032-91437	1
28	Arm assembly	S22-15520	1	S22-15520	1
29	O-Ring, 70 S-1 ARP 035	671-00035	1	671-00035	1
30	Dowel Pin, 1/8 Dia x 1.75 Lg.	324-20828	1	324-20828	1
33	Retaining Ring	356-30037	1	356-30037	1
34	Washer	032-91517	1	032-91517	1
35	O-Ring, 70 S-1 ARP 011	671-00011	2	671-00011	2
36	Block	032-91509	1	032-91509	1
37	Screw, 1/4-20 x 2-1/4	306-40187	3	306-40187	3
39	O-Ring, 90 S-1 ARP 908	691-00908	1	691-00908	1
41	Proportional Press. Cont. Valve	517-00095	1	517-00095	1
42	Coil, 24VDC	517-00096	1	517-00096	1
	Coil, 12VDC	517-00097		517-00097	
43	Connector	167-01008-8		167-01008-8	1
44	O-Ring, 90 S-1 ARP 904	691-00904	1	691-00904	2
45	Plug, SAE-4	488-35061	1	488-35061	1
46	Screw, SHC 10-32 x 1/4	312-09041	2	312-09041	2
49	Fitting	-		032-91507	1

DISASSEMBLY

1. See Figure 18. Remove 3 screws (37) holding block (36) to body (16).
2. Remove 2 screws holding body (16) to cap assembly (1).
3. Remove all parts from body (16) except pin (30) and arm assembly (28). It is not necessary to remove these parts unless broken or worn. Examine parts for wear or damage.
4. Remove screw (3). Examine head for excessive wear, and body for smooth sealing surface with O-ring.
5. See Figure 16. Remove tube lines to cap assembly.
6. Remove screws holding cap assembly to pump body.
7. Remove cap assembly (1). Remove plug (3) with attached parts. Remove spring (8) and spool (4).
8. Do not remove sleeve in body (1). Sleeve is pressed into cap and finished to size. If sleeve or cap is worn, replace the cap-sleeve assembly (1).
9. Remove screw (14) and nut (15). Push a rod through the cap to remove the retainer (12).

ASSEMBLY**See page 26 for tightening torque on plugs**

1. See Figure 16. Install Avseal plug (6) in cap.
2. Install spool (4) into bore as shown. Install spring (8) over end of spool.
3. Install O-ring (13) on spring retainer (12). Install retainer (12), screw (14), and nut (15) in plug (3).
4. Install O-rings (7) and (16) on plug (3). Install plugs (3) and (9) in body (1). Install orifice (20) and plugs(10). Torque plugs. Install O-ring (5) in cap.
5. Turn screw (14) in until spring retainer (12) contacts spring (8). Turn an additional 1-1/2 turns and lock in position.
6. Note proper location for control on pump (pg 24). Install O-rings on interface between cap and pump control pad. Install cap on pump control pad, guiding the control piston into the bore.
7. Torque two assembly bolts to 75 lb.·ft., 102 N m.
8. See Figure 18. Apply Loctite 242 on threads of screw (3), lubricate the shank, thread through the cap into the control piston, and torque to 5 lb.·ft., 6.78 N·m.
9. Install minimum stop screw (24) and turn clockwise to stroke pump to full volume. Measure height from control cap to top of screw (3). With control piston at full stroke, dimension must be .45 +/- .03 in., 11,4 +/- 0,76 mm. Back out minimum stop screw (24) till there is no contact with control piston.
10. Press dowel (30) into body (16), through the link (28), to 1/4, 6,35 mm below surface, apply Loctite Hydraulic Sealant to threads of screws (46) and install over dowel (30).
11. Press spool (21) into retainer (19). Caution: do not use excessive force. Place spool/retainer assembly into spool (17) with spring (18) and washer (34). Secure with retaining ring (33).
12. While sleeve (27) is engaged into dowel on link (28), slide above spool assembly into bore of body (16), and through sleeve (27). Spool (21) must move freely and easily at all positions of the link (28).
13. Install proportional valve (41) in block. Torque to 20 ft.·lbs., 27 N m.
14. Install coil on proportional valve. Torque to 20-25 in.·lbs., 2,2-2,8 N m max.
15. Assemble all other components into body (16) per above drawing. Torque the plug (12).
16. While spring retainer is engaging clevis pin (5) under dowel of link (28), slide the other opening of spring retainer over the top of the screw (3). Attach body assembly (16) to cap (1) with two screws and torque to 75 lb.·ft., 102 N m.
17. Install tubing assembly (Figure 24, 25).

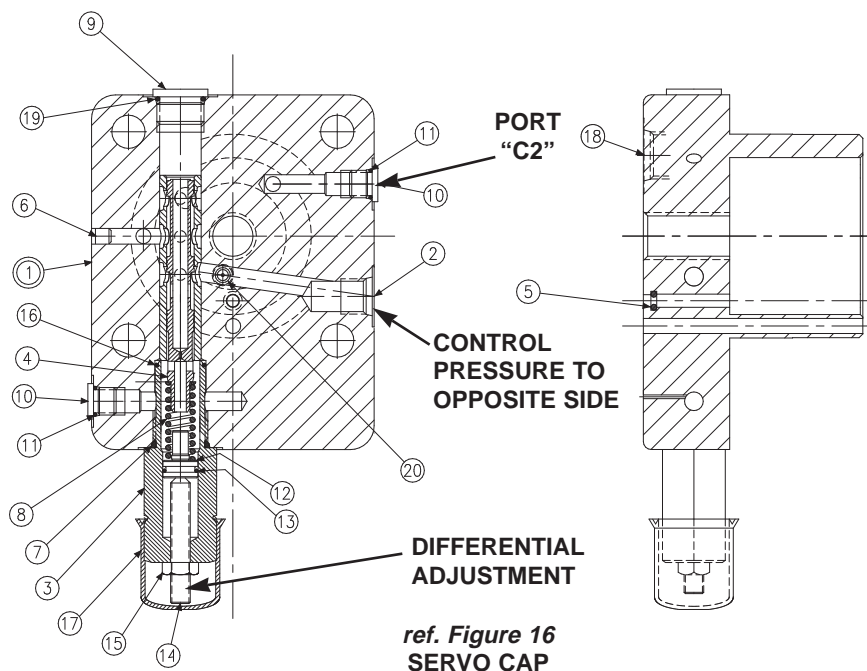

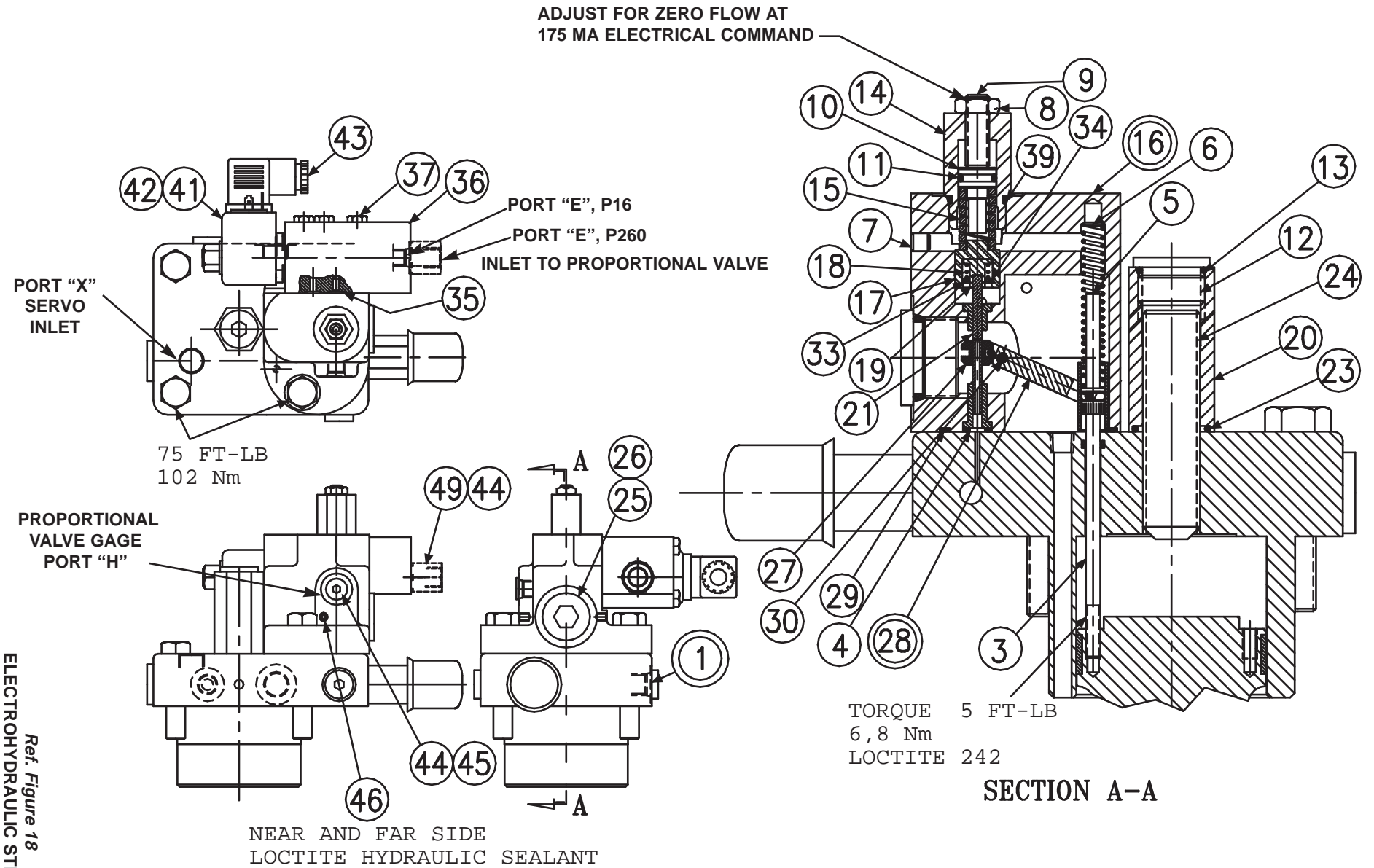

Ref. Figure 18
ELECTROHYDRAULIC STROKER

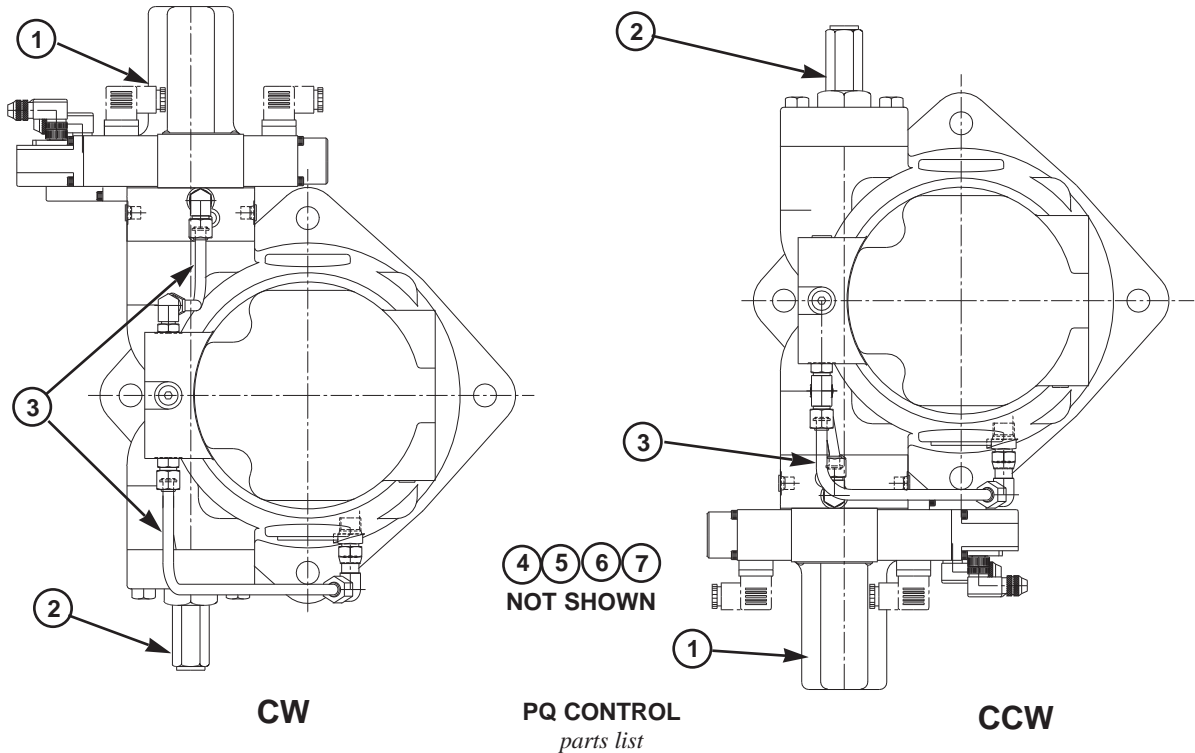

ITEM	DESCRIPTION	P16 PART NO.	P260 PART NO.	QTY.	
				CW	CCW
1	PQ Control (Fig.21)	S22-15963	S22-15964	1	1
2	Max Volume Stop (Fig. 23)	S22-16126	S22-16126	1	1
3	Tube Assembly (Fig. 19)	P22-16070	P22-16071	1	-
	Tube Assembly (Fig. 20)	P22-16118	P22-16119	-	1
4	Control Piston	032-92505	032-92505	1	1
5	O-Ring, 90 S-1 ARP 013	691-00013	691-00013	2	2
6	O-Ring, 70 S-1 ARP 152	671-00152	671-00152	2	2
7	Piston Ring	032-91261	032-91261	2	2

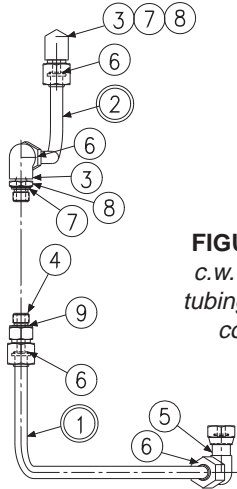

FIGURE 19
c.w. control
tubing for pq
control

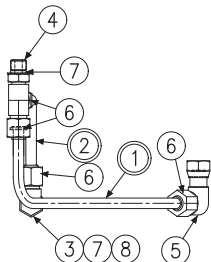

FIGURE 20
c.c.w. control
tubing for pq
control

PARTS LIST FOR FIGURE 19
CW control tubing for PQ control

ITEM	DESCRIPTION	P16		P260	
		PART NO.	QTY.	PART NO.	QTY
1	Float tube w/nut & sleeve	S22-15965	1	S22-16120	1
2	Servo tube w/nut & sleeve	S22-15966	1	S22-16121	1
3	Male elbow fitting	492-15382	2	492-15436	2
4	Fitting, male conn.	492-15433	1	492-15433	1
5	Swivel nut elbow fitting	492-15431	1	492-15428	1
6	O-ring, 90 S-1 ARP 012	691-00012	4	691-00012	4
7	O-ring	691-00906	3	691-00111	2
8	Fitting retaining ring 1/4	-	-	492-15416	2
9	Ring, soft seal VSTI 1/4	-	-	605-10061	1

PARTS LIST FOR FIGURE 20
CCW control tubing for PQ control

ITEM	DESCRIPTION	P16		P260	
		PART NO.	QTY.	PART NO.	QTY
1	Float tube w/nut & sleeve	S22-16122	1	S22-16124	1
2	Servo tube w/nut & sleeve	S22-15966	1	S22-16121	1
3	Male elbow fitting	492-15382	2	492-15436	1
4	Fitting, male conn.	492-15438	1	492-15437	1
5	Swivel nut elbow fitting	492-15431	1	492-15428	1
6	O-ring, 90 S-1 ARP 012	691-00012	4	691-00012	4
7	O-ring	691-00906	3	691-00111	2
8	Fitting retaining ring 1/4	-	-	492-15416	2

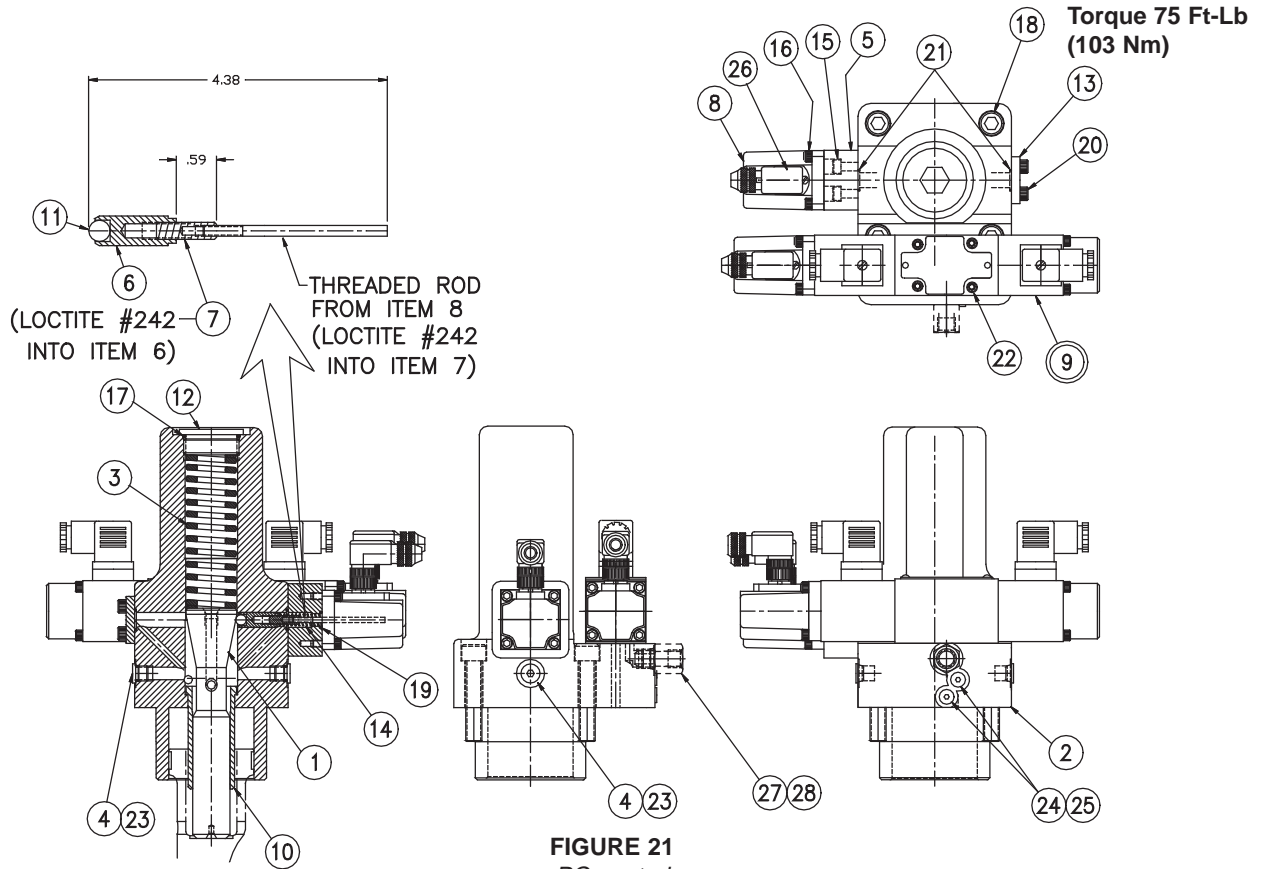

FIGURE 21
PQ control

PARTS LIST FOR FIGURE 21
P16 PQ control S22-15963
P260 PQ control S22-15964

ITEM	DESCRIPTION	P16		P260	
		PART NO.	QTY.	PART NO.	QTY.
1	Piston servo cone	032-92509	1	032-92509	1
2	Cap	032-92578	1	032-92578	1
3	Spring	225-92119	1	225-92119	1
4	Plug, SAE-4	488-35061	2	488-35061	2
5	Sensor base	032-92309	1	032-92309	1
6	Guide	032-92275	1	032-92275	1
7	Feedback extender	032-92310	1	032-92310	1
8	DC/DC LVDT	788-30012	1	788-30012	1
9	Valve, 4DC01 F40 A (Fig. 22)	026-65909	1	026-65909	1
10	Buckdown sleeve	032-92503	1	032-92503	1
11	Ball, 5/16 chrome	201-10001	1	201-10001	1
12	Plug, SAE-20	488-35019	1	488-35019	1
13	Cover	032-92565	1	032-92565	1
14	Spring	225-92117	1	225-92117	1
15	Screw, SHC, M6 x 18 mm	361-08184	4	361-08184	4
16	Screw, SHC, M5 x 16 mm	361-07164	4	361-07164	4
17	O-ring, 90 S-1 ARP 920	691-00920	1	691-00920	1
18	Screw, SHC M12 x 60 mm	361-12284	4	361-12284	4
19	O-ring, 70 S-1 ARP 012	671-00012	1	671-00012	1
20	Screw, SHC, M6 x .12 mm	361-08124	4	361-08124	4
21	O-ring, 70 S-1 ARP 014	671-00014	2	671-00014	2
22	Screw, SHC 10-24 x 1-1/4	358-10180	4	358-10180	4
23	O-ring, 90 S-1 ARP 904	691-00904	2	691-00904	2
24	Plug, SAE-2	488-35046	2	488-35046	2
25	O-ring, 90 S-1 ARP 902	691-00902	2	691-00902	2
26	Connector	721-30108	1	721-30108	1
27	Fitting, Adapter	-	-	492-15435	1
28	O-ring, 90 S-1 ARP 906	-	-	691-00906	1

DISASSEMBLY

1. See Figure 21. With pump on full stroke, remove plug (12) and spring (3) from cap (2).
2. Remove LVDT feedback assembly (8) from cap. Remove sensor base (5), spring (14) and feedback rod assembly (6, 7, and 11)
3. Remove tubing assembly. Remove proportional valve with LVDT, item (9).
4. Remove screws (18) and slip cap off pump.
5. Examine servo cone piston (1) and sleeve (10) for wear or binding in the bore.

ASSEMBLY

See page 26 for tightening torque on plugs

1. Press sleeve (10) into cap (2). Slip piston (1) into cap and check for free travel over the full to zero stroke range.
2. Note proper location of cap on pump (pg. 24). Install O-rings to interface between cap and pump. Install cap on pump. Torque assembly bolts (18) to 75 ft-lbs, 103 Nm.
3. Insert spring (3) over spool (1) and install plug (12) with O-ring (17).
4. Thoroughly degrease feedback rod assembly (6), (7) and rod from (8). Apply loctite 242 on threads. Assemble to the dimensions indicated. Allow loctite to set then check to see that rod assembly is firmly retained.
5. Use vaseline to retain ball (11) in guide (6). Insert guide in cap (2). Sensor may be installed on either side.
6. Install O-rings (21) to cover (13) and sensor base (5). Install to cap (1). Torque screws (15) and (20) to 106 in.-lb, 12 Nm.
7. Install stroke sensor LVDT (8) with O-ring (19) over sensor rod on cap. Torque screws (16) to 62,8 in.-lb, 7,1 Nm.
7. Install proportional valve with LVDT, (9). Torque screws (22) to 66 in.-lb, 7,5 Nm.
8. For 260 series, install adapter, (27).
9. Install tubing assembly (Figure 19, 20).

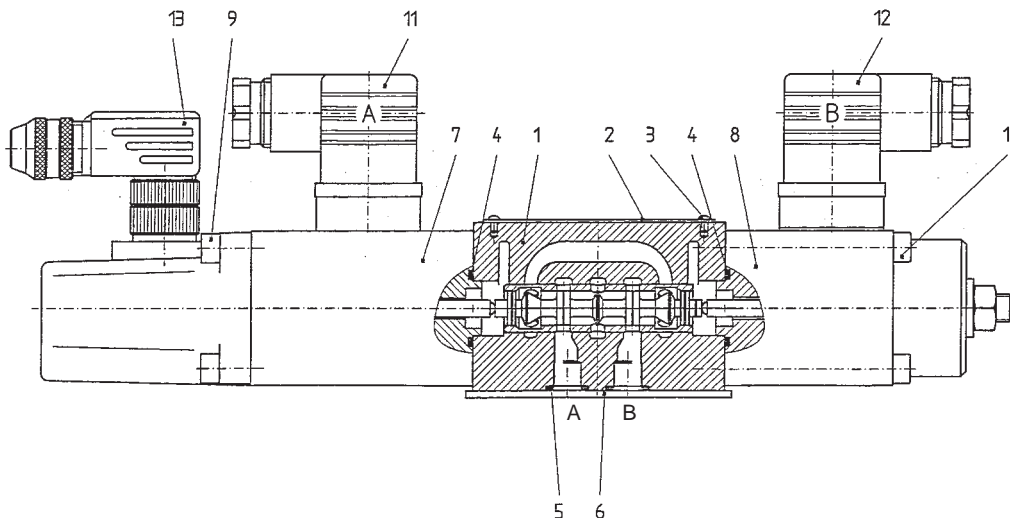
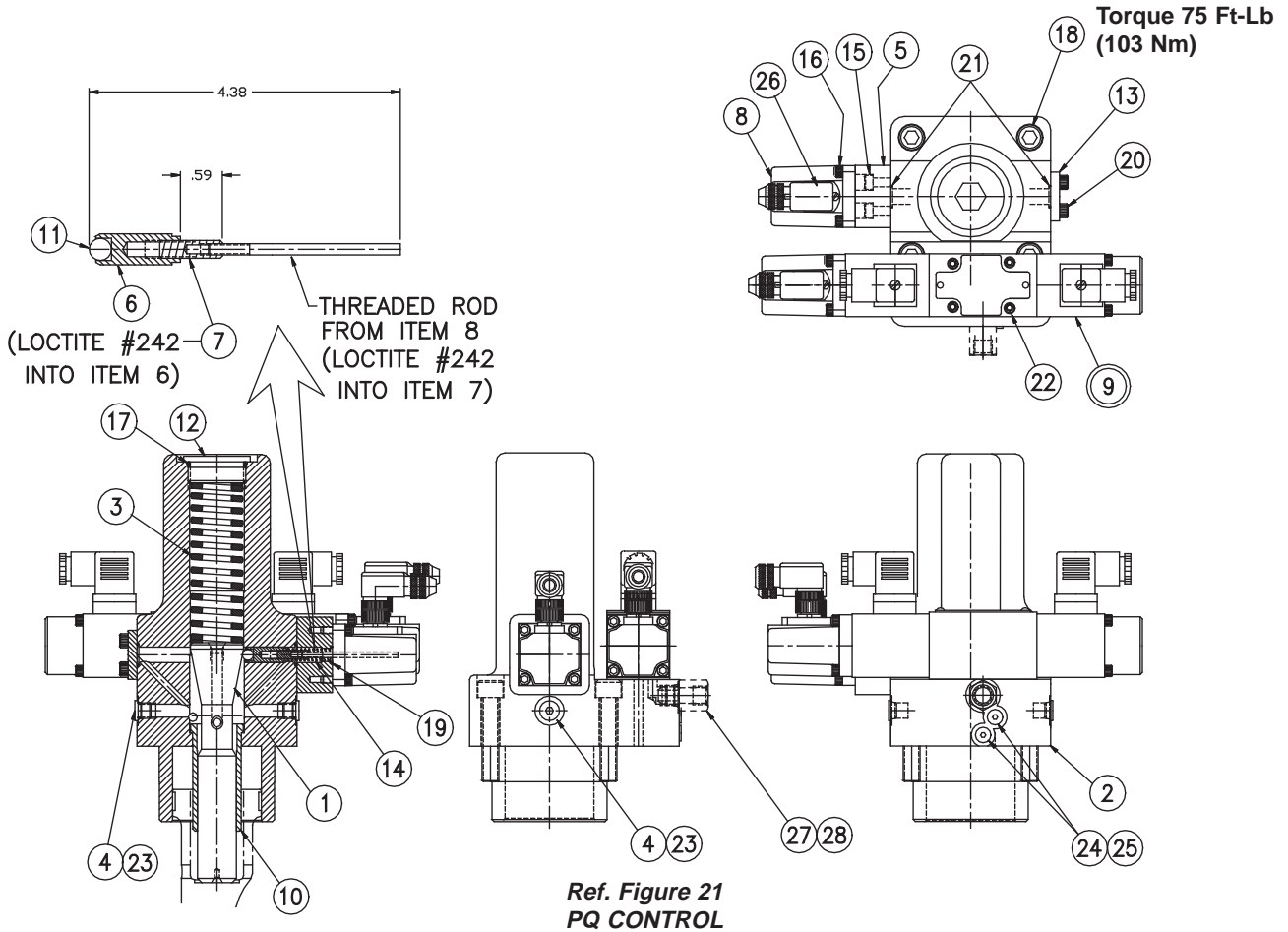

FIGURE 22
proportional valve with LVDT

PARTS LIST FOR FIGURE 22
proportional valve with LVDT 026-65909

ITEM	DESCRIPTION	PART NO.	QTY.
1	Body, micro-lap 40L	S26-58777	1
2	Data plate	036-84770	1
3	Drive screw	320-10203	2
4	O-ring, 90 S-1 ARP 018	691-00018	2
5	O-ring, 90 S-1 ARP 012	691-00012	4
6	Dust plate	036-39820	1
7	Solenoid with LVDT	120-03044-8	1
8	Solenoid without LVDT	120-03043-8	1
9	Screw, SHC, M5 x 80mm	361-00033-8	4
10	Screw, SHC, M5 x 55mm	361-00013-8	4
11	Plug-in connector, "A" (grey)	167-01007-8	1
12	Plug-in connector, "B" (black)	167-01008-8	1
13	Connector, LVDT	167-01106-8	1



CONTROL CAP DISASSEMBLY

1. See Figure 23. Remove nut (9) and Max. volume screw (11).
2. Remove guide (1).
3. Remove 4 screws (12) holding cap to pump.
4. Remove cap assembly from pump. Check piston and sleeve for wear and free motion.

ASSEMBLY

See page 26 for tightening torque on plugs

1. Install Avseal plug (8). Press sleeve (4) into cap to shoulder. Install piston (1), checking for free motion.
2. Install O-rings on interface between cap and pump control pad. Install cap on pump housing as indicated on the applicable view (pg. 24), guiding the control piston into the bore.
3. Torque the assembly bolts (12) to 75 lb.-ft., 103 Nm.
4. Install O-ring (6) on guide (1). Install guide in cap (5). Torque guide (1) to 140 Ft-Lbs, 190 Nm..
5. Install screw (11) in cap. Install O-ring (10) on nut (9). Install nut (9) on screw.
6. Adjust screw till pump is slightly off full stroke and lock nut (9).
7. Install O-ring (7) on plug (3). Install plug in nut (9). Torque plug (3) to 75 lb.-ft., 103 Nm.

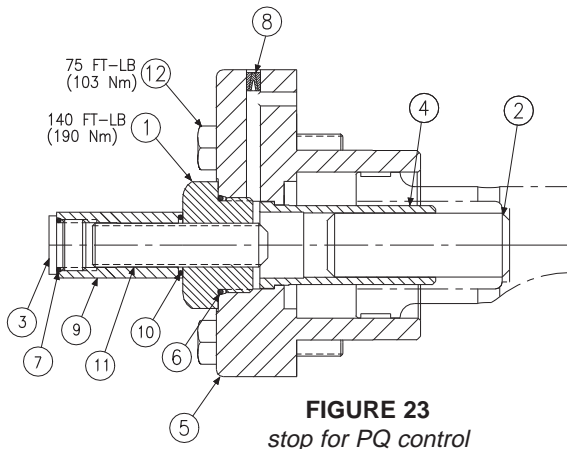

PARTS LIST FOR FIGURE 23
stop S22-16126 for PQ control

ITEM	DESCRIPTION	PART NO.	QTY.
1	Guide	032-92519	1
2	Buckdown piston	032-92554	1
3	Plug, SAE-10	488-35055	1
4	Sleeve	032-92503	1
5	Control Cap	032-92248	1
6	O-ring, 90 S-1 ARP 920	691-00920	1
7	O-ring 90 S-1 ARP 910	691-00910	1
8	Plug, Avseal	447-00026	1
9	Nut	031-91049	1
10	O-ring, 70 S-1 ARP 118	671-00118	1
11	Screw, 3/4-10 x 3	311-26320	1
12	Screw, SHC M12 x 60mm	363-12210	4

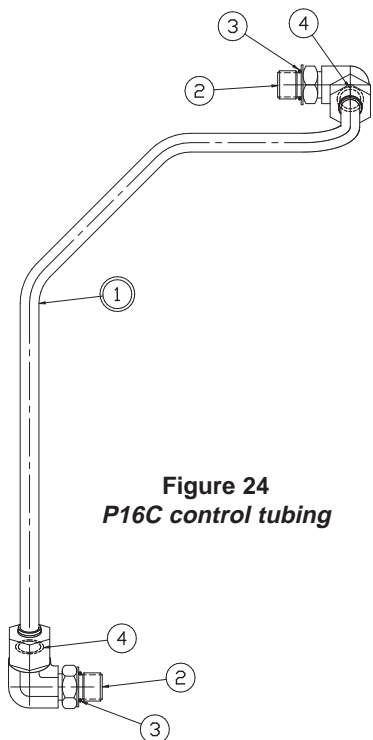

Figure 24
P16C control tubing

PARTS LIST FOR FIGURE 24
P16C control tubing S22-15981

ITEM	DESCRIPTION	PART NO.	QTY.
1	Servo tube w/nut & sleeve	S22-15982	1
2	Elbow fitting	492-15382	2
3	O-ring, 90 S-1 ARP 906	691-00906	2
4	O-ring, 90 S-1 ARP 012	691-00012	2

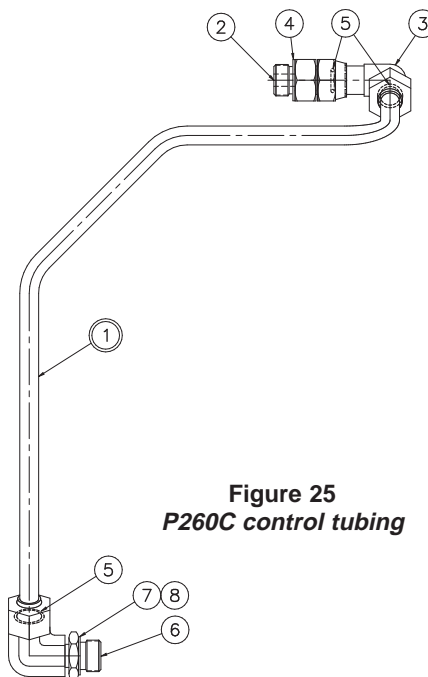

Figure 25
P260C control tubing

PARTS LIST FOR FIGURE 25
P260C control tubing S22-15998

ITEM	DESCRIPTION	PART NO.	QTY.
1	Servo tube w/nut & sleeve	S22-15999	1
2	Male connection fitting	492-15427	1
3	Swivel nut elbow fitting	492-15428	1
4	Ring, soft seal VSTI 3/8	605-10062	1
5	O-ring, 90 S-1 ARP 012	691-00012	3
6	Male elbow fitting	492-15426	1
7	Fitting retaining ring 3/8	492-15417	1
8	O-ring, 90 S-1 ARP 113	691-00113	1

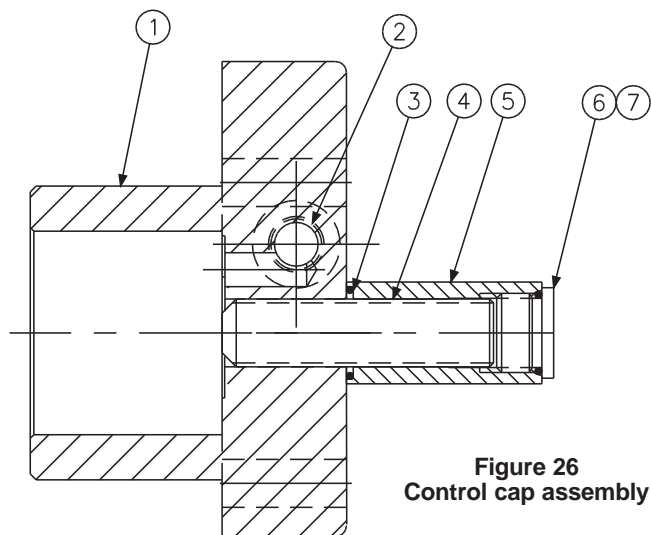

Figure 26
Control cap assembly

PARTS LIST FOR FIGURE 26
P16 control cap assembly S22-15256
P260 control cap assembly S22-15272

ITEM	DESCRIPTION	P16		P260	
		PART NO.	QTY.	PART NO.	QTY.
1	Control Cap	032-91764	1	032-91766	1
2	Plug	449-00015	1	449-00599	1
3	O-ring, 70 S-1 ARP 118	671-00118	1	671-00118	1
4	Screw, 3/4-10 x 3	311-26320	1	311-26320	1
5	Nut	031-91049	1	031-91049	1
6	Plug, SAE-10	488-35055	1	488-35055	1
7	O-ring 90 S-1 ARP 910	691-00910	1	691-00910	1

CONTROL CAP DISASSEMBLY

1. See Figure 26. Remove nut (5) and Max. volume screw (4).
2. Remove 4 screws holding cap to pump.
3. Remove cap assembly from pump.

ASSEMBLY

See page 26 for tightening torque on plugs

1. Install O-rings on interface between cap and pump control pad. Install cap on pump housing as indicated on the applicable view (pg. 24), guiding the control piston into the bore.
2. Torque the assembly bolts to 75 lb.·ft., 102 Nm.
3. Install screw (4) in cap. Install O-ring (3) on nut (5). Install nut (5) on screw.
4. Adjust screw till pump is slightly on stroke and lock nut (5).
5. Install O-ring (7) on plug (6). Install plug in nut (5). Torque plug (6).

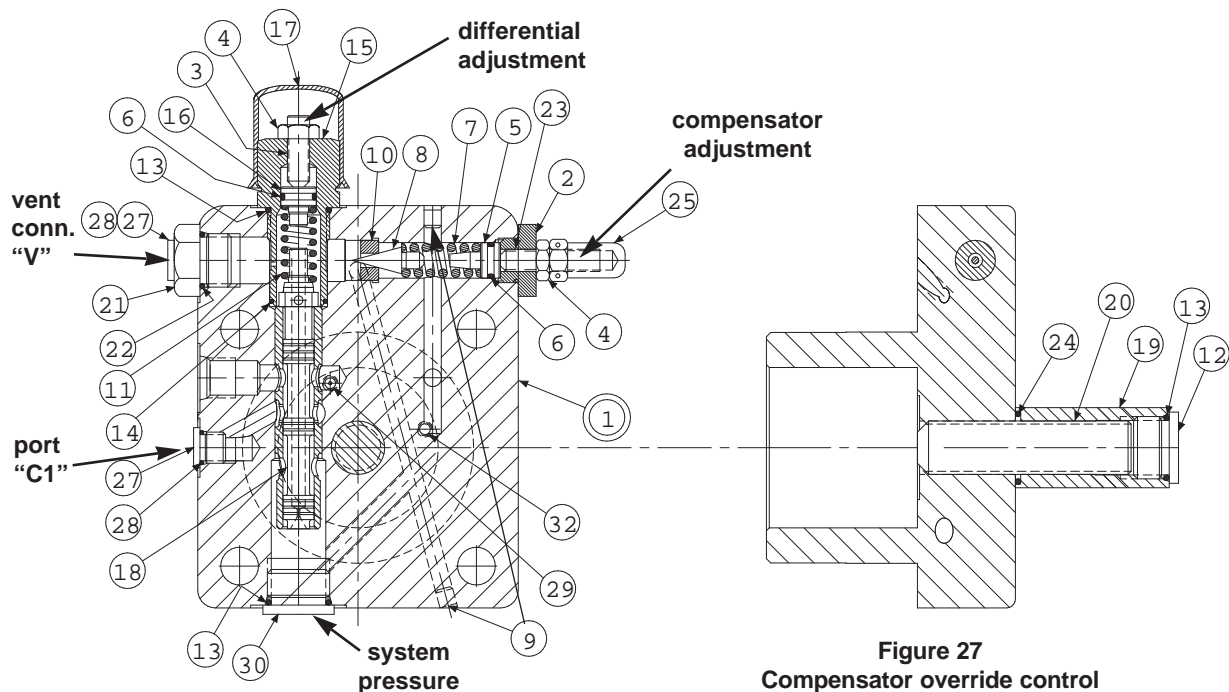

Figure 27
Compensator override control

PARTS LIST FOR FIGURE 27
 compensator override control
 P16 compensator override S22-16007
 P260 comp. override S22-16008

ITEM	DESCRIPTION	P16		P260	
		PART NO.	QTY.	PART NO.	QTY.
1	Cap-Sleeve Assembly	S22-15989	1	S22-15990	1
2	Adjustment Plug	032-91814	1	032-91814	1
3	Socket Setscrew 5/16-24 x 1	312-13160	1	312-13160	
4	Nut, 5/16-24	335-13100	2	335-13100	2
5	Seal Piston	031-59367	1	031-59367	1
6	O-Ring, 90 S-1 ARP 012	691-00012	2	691-00012	2
7	Spring	032-91798	1	032-91798	1
8	Cone	036-12288	1	036-12288	1
9	Avseal Plug	447-00026	2	447-00026	2
10	Seat	036-11692	1	036-11692	1
11	Spring	225-92101	1	225-92101	1
12	Plug, SAE-10	488-35055	1	488-35055	1
13	O-Ring, 90 S-1 ARP 910	691-00910	3	691-00910	2
14	O-Ring, 90 S-1 ARP 017	691-00017	1	691-00017	1
15	Plug	031-57368	1	031-57368	1
16	Seal piston	032-92480	1	032-92480	1
17	Cap	449-00612	1	449-00612	1
18	Spool	032-92549	1	032-92549	1
19	Cover	032-91049	1	032-91049	1
20	Screw, 3/4-10 x 3	311-26320	1	311-26320	1
21	Plug	492-15423	1	492-15425	1
22	O-ring, 90 S-1 ARP 908	691-00908	1	-	-
23	Soc. Setscrew 5/16-24 x 1-1/4	312-13180	1	312-13180	1
24	O-ring, 70 S-1 ARP 118	671-00118	1	671-00118	1
25	Acorn Nut	036-33474	1	036-33474	1
27	Plug, SAE-4, 1/4 BSPP	488-35061	2	447-01004	2
28	O-ring, 90 S-1 ARP 904	691-00904	2	-	-
29	Orifice	035-40489	1	035-40489	1
30	Plug, SAE-10, 1/2 BSPP	488-35055	1	447-01008	1
32	Screw, SHC	311-10041	1	311-10041	1

DISASSEMBLY

1. See Figure 27. Remove tube line to cap.
2. Remove maximum volume stop assembly (items 12, 13, 19, 20, 24).
3. Remove cap assembly.
4. Remove plug (15) and attached parts. Remove spring (11) and spool (18).
5. Remove adj. plug (2) and attached parts. Remove seal piston (5). Note: a 10-24 screw may be attached to assist in pulling the piston. Remove spring (7) and cone (8).
6. Do not remove sleeve in body (1). Sleeve is pressed into cap and finished to size. If sleeve, snout or cap is worn, replace the cap-sleeve assembly (1).
7. Examine seat (10) for wear. Do not remove unless damaged.

ASSEMBLY

See page 26 for tightening torque on plugs

1. Install Avseal plugs (9) in body. Install orifice (29) and plug (32) as shown.
2. Press seat (10) into bore to shoulder in bore.
3. Install spool (18) into bore as shown. Install spring (11) over end of spool. Install O-ring (6) on seal piston (16). Lubricate and install into plug (15). Install O-rings (13) and (14) on plug (15). Install plug (15) into cap. Install screw (3), nut (4) and acorn nut (17).
4. Install O-ring (6) on seal piston (5).
5. Lubricate O-ring and install cone (8), spring (7) and seal piston into bore in cap (1), being careful that cone enters seat (10).
6. Install remaining parts. Torque plugs (12) (21) (27) and (30).
7. Note proper location for cap on pump (pg. 24). Install O-rings on interface between cap and pump control pad.
8. Install cap assembly on pump, guiding the control piston into the bore.
9. Torque mounting bolts to 75 lb.·ft., 102 Nm.
10. Install tubing assembly (Figure 24, 25).

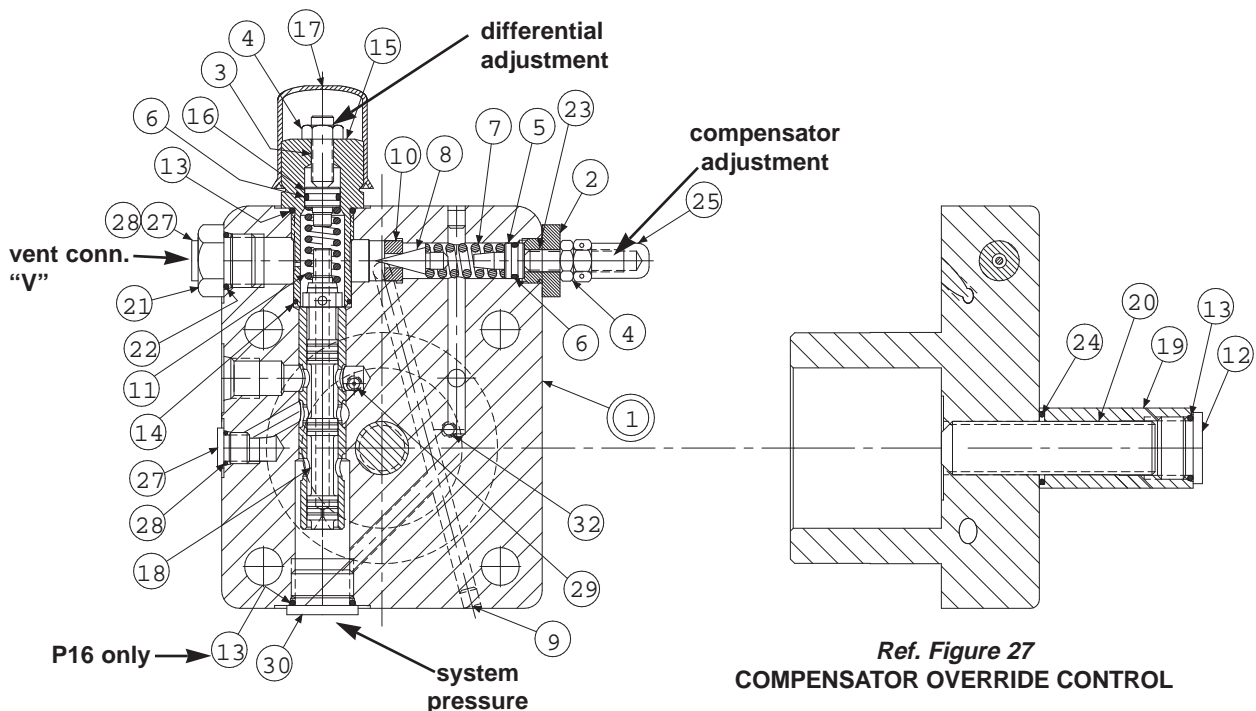

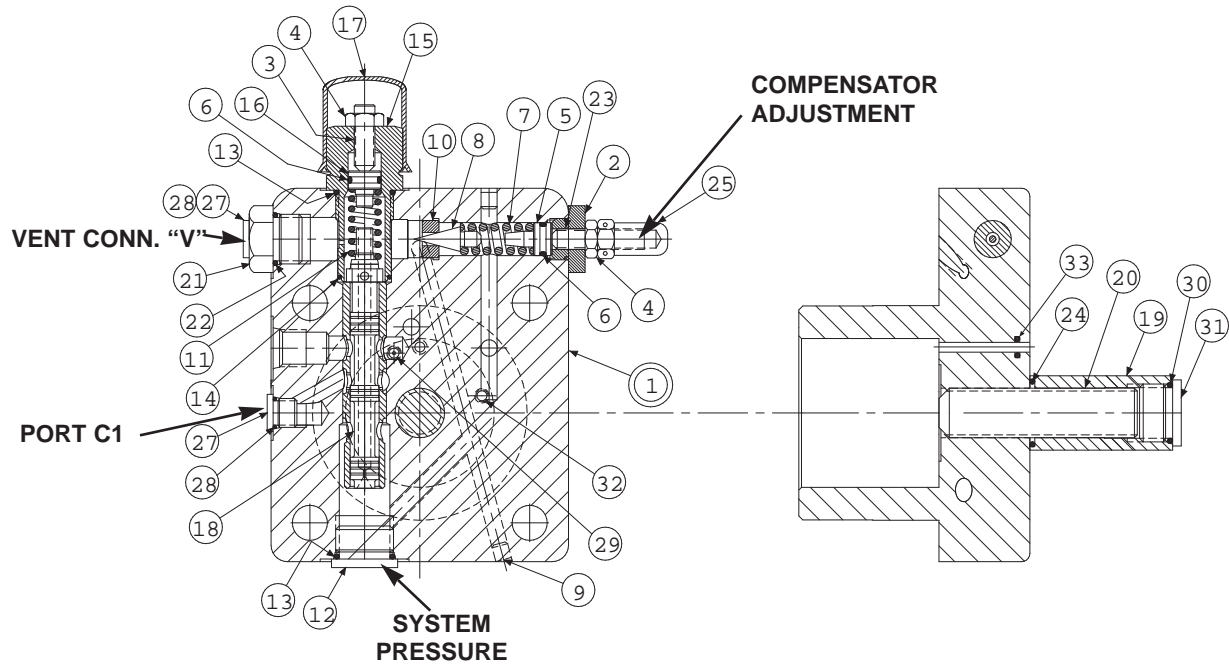

FIGURE 28
torque limiter override cap

PARTS LIST FOR FIGURE 28

torque limiter override cap
P16 cap S22-15993
P260 cap S22-15994

ITEM	DESCRIPTION	P16		P260	
		PART NO.	QTY.	PART NO.	QTY
1	Cap-Sleeve Assembly	S22-15991	1	S22-15992	1
2	Adjustment. Plug	032-91814	1	032-91814	1
3	Socket Setscrew 5/16-24 x 1	312-13160	1	312-13160	1
4	Nut, 5/16-24	335-13100	2	335-13100	2
5	Seal Piston	031-59367	1	031-59367	1
6	O-Ring, 90 S-1 ARP 012	691-00012	2	691-00012	2
7	Spring	032-91798	1	032-91798	1
8	Cone	036-12288	1	036-12288	1
9	Avseal Plug	447-00026	2	447-00026	2
10	Seat	036-11692	1	036-11692	1
11	Spring	225-92101	1	225-92101	1
12	Plug, SAE-10, 1/2 BSPP	488-35055	1	447-01008	1
13	O-Ring, 90 S-1 ARP 910	691-00910	2	691-00910	1
14	O-Ring, 90 S-1 ARP 017	691-00017	1	691-00017	1
15	Plug	031-57368	1	031-57368	1
16	Seal Piston	032-92480	1	032-92480	1
17	Cap	449-00612	1	449-00612	1
18	Spool	032-92549	1	032-92549	1
19	Cover	032-91761	1	032-91761	1
20	Screw, 1/2-20 x 2-1/2	312-35060	1	312-35060	1
21	Fitting	492-15423	1	492-15425	1
22	O-ring 90 S-1 ARP 908	691-00908	1	-	-
23	Soc. Setscrew	312-13180	1	312-13180	1
24	O-Ring, 70 S-1 ARP 015	671-00015	1	671-00015	1
25	Acorn Nut	036-33474	1	036-33474	1
26	Plug	449-00015	1	449-00599	1
27	Plug, SAE-4, 1/4 BSPP	488-35061	2	447-01004	2
28	O-ring, 90 S-1 ARP 904	691-00904	2	-	-
29	Orifice	035-40489	1	035-40489	1
30	O-Ring, 90 S-1 ARP 905	691-00015	1	691-00015	1
31	Plug, SAE-5	488-35020	1	488-35020	1
32	Screw, SHC	311-10041	1	311-10041	1
33	O-Ring, 70 S-1 ARP 008	671-00008	1	671-00008	1

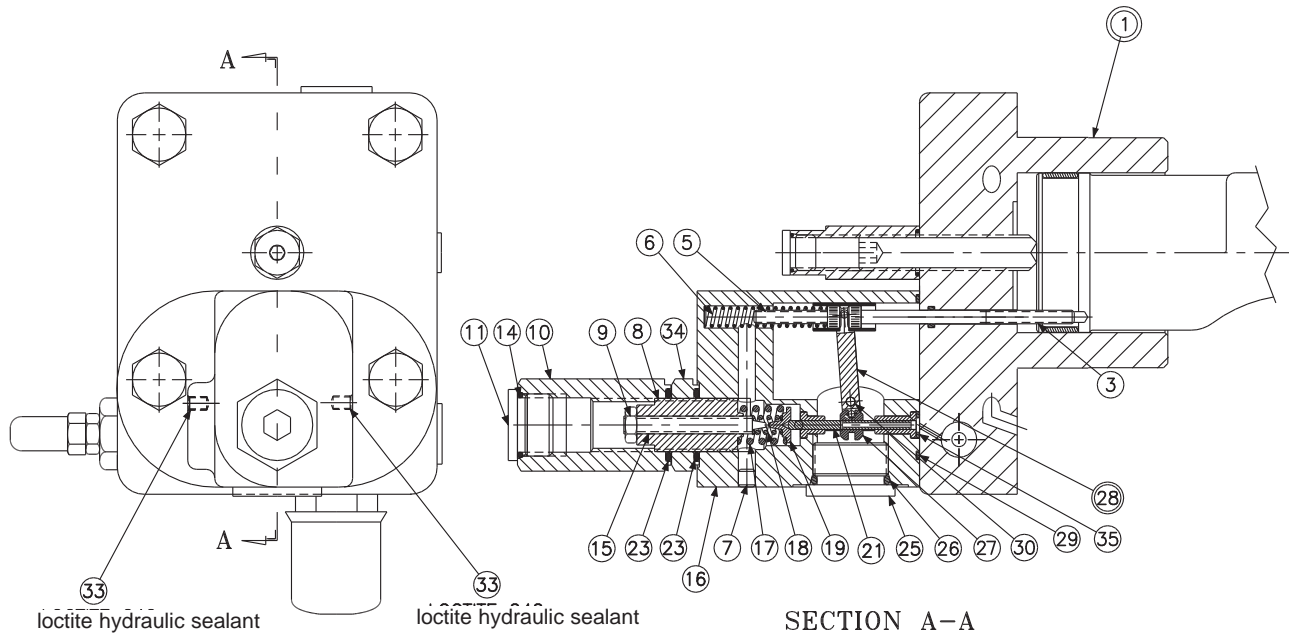

FIGURE 29
TORQUE LIMITER OVERRIDE

PARTS LIST FOR FIGURE 29

torque limiter override
P16 code J S22-16009
P16 code K S22-16011
P260 code J S22-16010
P260 code K S22-16012

ITEM	DESCRIPTION	P16	P260	QTY.	
		PART NO.	PART NO.	**J	**K
1	Cap (Figure 28)	S22-15993	S22-15994	1	1
3	Screw	032-91461	032-91461	1	1
5	Clevis pin	321-40000	321-40000	1	1
6	Spring, Compression	032-92100	032-92100	1	1
7	Plug, Avseal	447-00026	447-00026	1	1
8	Screw	032-91445	032-91445	1	1
9	Nut, Hex Jam 1/4-20 UNC	340-00038	340-00038	1	1
10	Hex Nut, 3/4-16 UNF	032-91449	032-91449	1	1
11	Plug, SAE-8	488-35018	488-35018	1	1
14	O-Ring, 90 S-1 ARP 908	691-00908	691-00908	1	1
15	Screw, Primary Adjustment	032-91446	032-91446	1	1
16	Body assembly	S22-15397	S22-15397	1	1
17	Outer Spring – J Version	032-91440	032-91440	1	—
	Outer Spring – K Version	032-91448	032-91448	—	1
18	Inner Spring – J Version	032-91441	032-91441	1	—
	Inner Spring – K Version	032-91447	032-91447	—	1
19	Spring Retainer	032-91819	032-91819	1	1
21	Spool	032-91438	032-91438	1	1
23	O-ring, 70 S-1 ARP 118	671-00118	671-00118	2	2
25	Plug, SAE-12	488-35014	488-35014	1	1
26	O-Ring, 90 S-1 ARP 912	691-00912	691-00912	1	1
27	Sleeve	032-91437	032-91437	1	1
28	Arm assembly	S22-15520	S22-15520	1	1
29	O-Ring, 70 S-1 ARP 035	671-00035	671-00035	1	1
30	Dowel Pin	324-20828	324-20828	1	1
33	Screw, SHC 10-32 x 1/4	312-09041	312-09041	2	2
34	Nut	032-91645	032-91645	1	1
35	O-Ring, 70 S-1 ARP 010	671-00010	671-00010	1	1

DISASSEMBLY

1. See figure 29. Remove 2 screws holding torque limiter body (16) to cap assembly (1).
2. Remove all parts from torque limiter body (16) except pin (30) and arm assembly (28). It is not necessary to remove these parts unless broken or worn. Examine parts for wear or damage.
3. Remove screw (3). Examine head for excessive wear, and body for smooth sealing surface with O-ring.
4. See figure 28. Remove maximum volume stop assembly (items 19, 20, 24, 30, 31).
5. Remove cap assembly (1).
6. Remove plug (15) and attached parts. Remove spring (11) and spool (18).
7. Remove adjusting plug (2) and attached parts. Remove seal piston (5). Note: a 10-24 screw may be attached to assist in pulling the piston. Remove spring (7) and cone (8).
8. Do not remove sleeve in body (1). Sleeve is pressed into cap and finished to size. If sleeve, snout or cap is worn, replace the cap-sleeve assembly (1).
9. Examine seat (10) for wear. Do not remove unless damaged.

ASSEMBLY

See page 26 for tightening torque on plugs

1. See figure 28. Install Avseal plugs (9) orifice (29) and screw (32).
2. Press seat (10) into bore squarely against shoulder in bore.
3. Install spool (18) into bore as shown. Install spring (11) over end of spool. Install O-ring (6) on seal piston (16). Lubricate and install into plug (15). Install O-rings (13) and (14) on plug (15) Install plug (15) into cap. Install screw (3), nut (4) and acorn nut (17).
4. Install O-ring (6) on seal piston (5).
5. Lubricate O-ring and install cone (8), spring (7) and seal piston into bore in cap (1), being careful that cone enters seat (10). Install adj. plug (2), screw (25), nut (4), and acorn nut (25).
6. Install plugs (12), (21) and (27) and torque.
7. Carefully install O-ring (33) into the cap.
8. Note proper location for cap (pg. 24). Install O-rings on interface between cap and pump control pad. Install cap assembly on pump, guiding the control piston into the bore. Torque two mounting screws to 75 lb.*ft., 102 Nm.
9. Install maximum stop screw (20), cover (19), O-ring (24) and plug (31) with O-ring (30).
10. See figure 29. Apply Loctite 242 on threads of screw (3), lubricate the shank, thread through the cap into the control piston, and torque to 5 lb.*ft., 6,78 Nm.
11. Measure height from control cap to top of screw. With control piston at zero stroke, dimension must be .45 +/- .03 in., 11,4 +/- 0,76 mm.
12. Press dowel (30) into body (16), through the link assembly (28), to 1/4", 6,35 mm below surface. Apply Loctite hydraulic sealant® to threads of screws (33) and install over dowel (30).
13. While sleeve (27) is engaged into dowel on link (28), slide spool (21) into bore of body (16), and through sleeve (27). Spool (21) must move freely and easily at all positions of the link (28).
14. Assemble remaining parts per drawing. Torque plug (11).
15. While spring retainer is engaging screw (5) under dowel of link (28), slide the other opening of spring retainer over the top of the screw (3). Attach body assembly (16) to cap (1) and torque assembly screws to 75 lb.*ft., 102 Nm.
16. Install tubing assembly (Figure 24, 25).

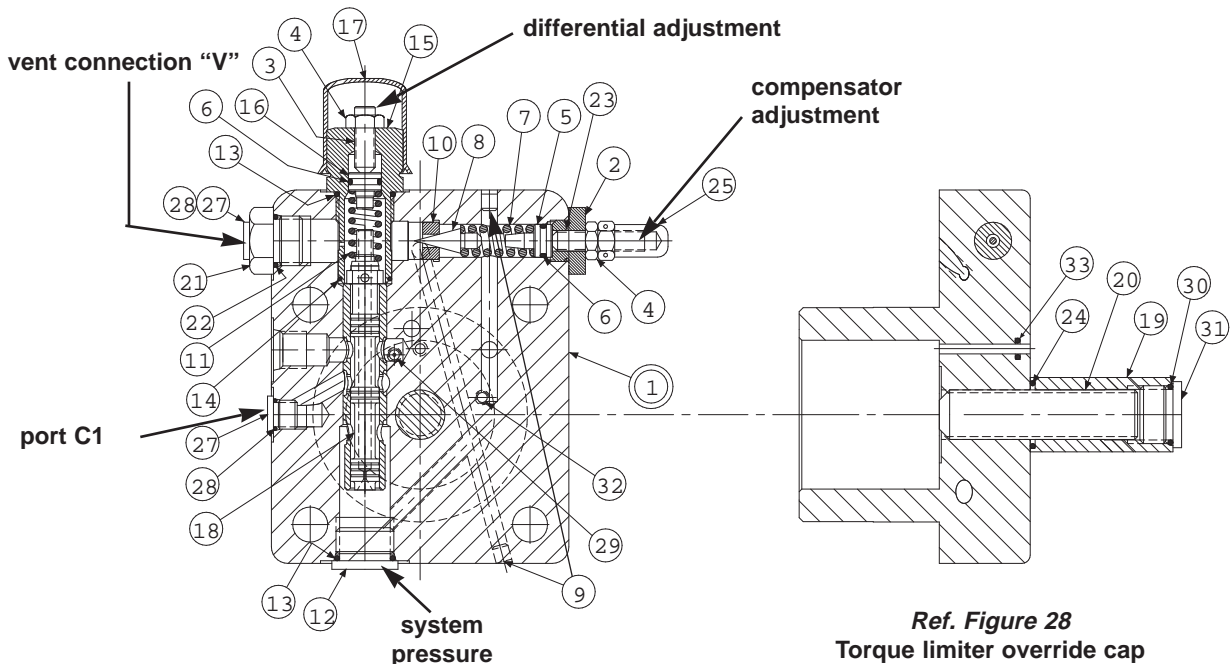

Test Conditions: (If using service facility test stand)

- Fluid: Mobil 4259 DE (ISO V6-32 or equivalent)
- RPM: 1450 or 1750 ± 50 RPM
- Inlet Temp: 120° F ± 10° F, 49° C ± 4° C
- Inlet Condition: Atmospheric to + 5 psi, 0,345 bar
- Case Pressure: 25 psi ±5 psi, 1,72 bar ± 0,345 bar

Mount pump on test stand, or customer system. System line must have a relief valve. Connect system lines and case drain line. Fill pump case with clean oil. If pump is mounted vertically with the shaft up, vent the case by removing the plug from port "DG" to purge trapped air. Dry all oil from exterior of pump to permit checking for external leaks. If leaks are detected at any time, they shall be repaired before proceeding.

Adjust maximum volume stop to full displacement by backing off screw or handwheel CCW until there is no contact with control piston.

ROTARY SERVO TEST

The rotary servo mounts on the minimum stroke side of the pump. It utilizes a rotating shaft containing a cam to position a pin, and a sleeve positioned by a feedback link to the control cylinder. The sleeve/pin combination meters pilot flow to position a 4-way valve. This valve is ported to both ends of the control cylinder. The 4-way spool directs oil to/from the control cylinder such that it moves in a direction to maintain the metered position between the sleeve and spool. The pump stroke is thus established by the position of the shaft.

A compensator or torque limiter override may be installed on the opposite side of the control piston. When the set pressure or torque is reached, system pressure is directed into the piston to reduce stroke, overriding the servo commanded position.

Before testing the rotary servo, disable the compensator or torque limiter override, if applicable, by turning the compensator differential adjustment fully in. **CAUTION:** System must contain a relief valve to limit system pressure. System relief valve should be set to minimum pressure.

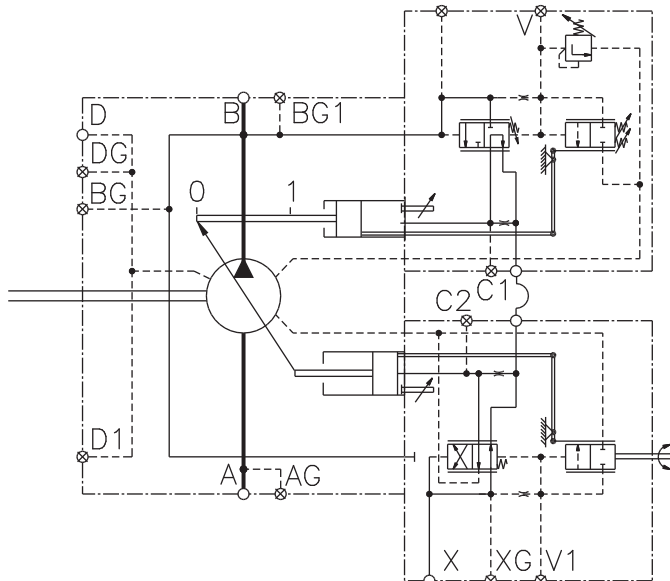

**HYDRAULIC CIRCUIT
ROTARY SERVO TORQUE
LIMITER OVERRIDE**

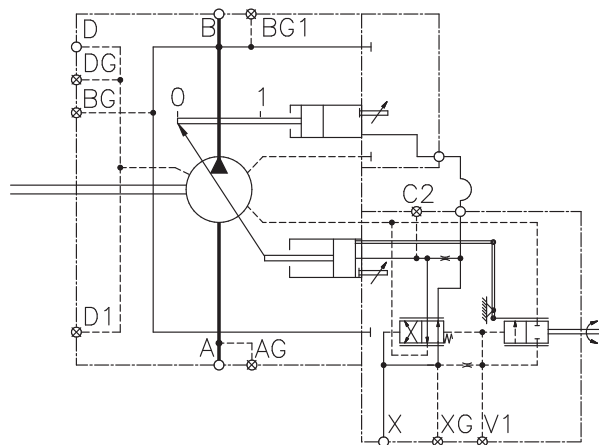

**HYDRAULIC CIRCUIT
ROTARY SERVO**

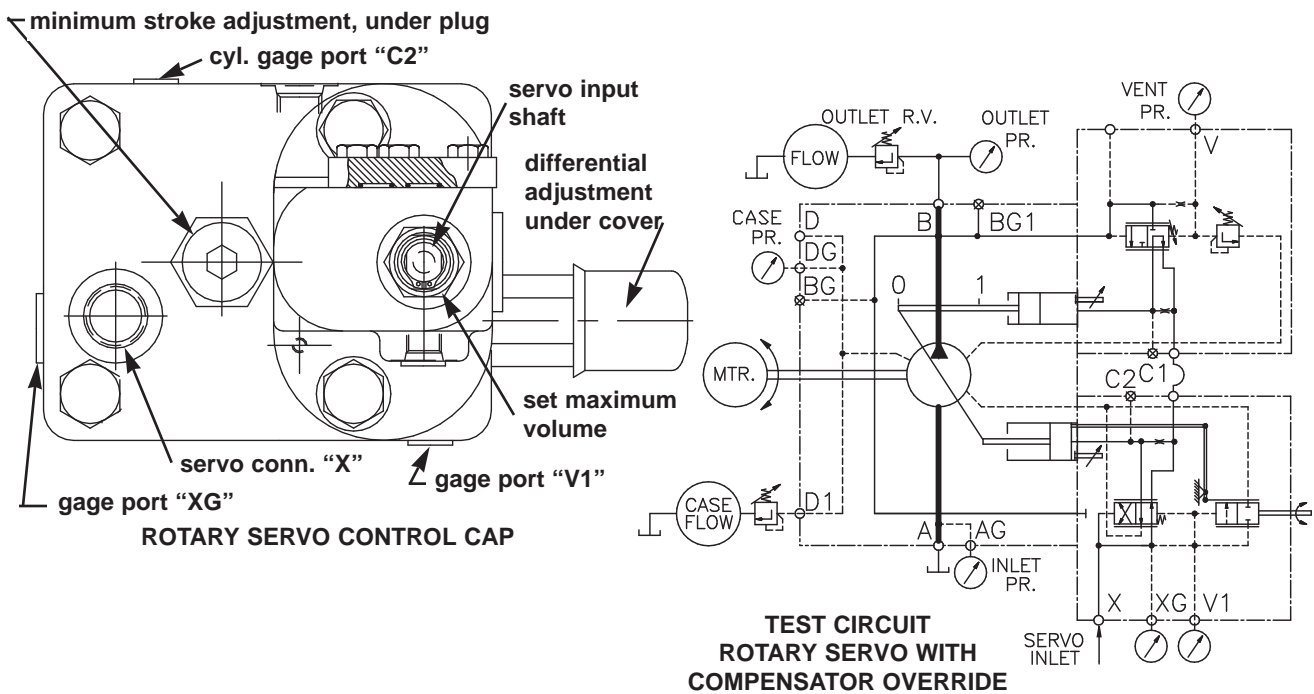

ROTARY SERVO TEST (continued)

Plumb servo supply (5 gpm, 19 lpm minimum at 1500 psi, 103 bar maximum) to control port "X".

Thread minimum stroke adjustment so that pump is on stroke.

Install gages on servo pressure gage port XG and on gage port V1, capable of measuring pressure difference to 10 psi, 0,69 bar. Gages must be adequate for servo pressure.

Turn servo differential adjustment screw in till solid, then seven turns out.

Start pump. Adjust rotary servo shaft till pump is at some stroke between zero and full. Adjust differential pressure by adjusting the differential screw until the difference in pressure readings between port XG and V1 is 250 psi, 17,2 bar. Install cover over differential adjustment. Remove gages and plug gage ports.

With rotary servo shaft rotated fully clockwise, adjust maximum volume adjustment on servo until output flow is at the full stroke position. Lock in place.

Fully rotate servo shaft counter-clockwise. Pump flow should go towards zero stroke. Back out minimum volume stop until pump is at zero stroke. Lock in place.

Rotate shaft clockwise and counterclockwise at various outlet pressures. Pump stroke should follow shaft rotation between full and zero stroke smoothly and proportionally. Full to zero or zero to full stroke should be achieved in no more than .3 second.

Proceed to **COMPENSATOR TEST (pg. 66)**, **TORQUE LIMITER TEST (pg. 70)**, or **FINAL PUMP TEST (pg. 75)**, as applicable.

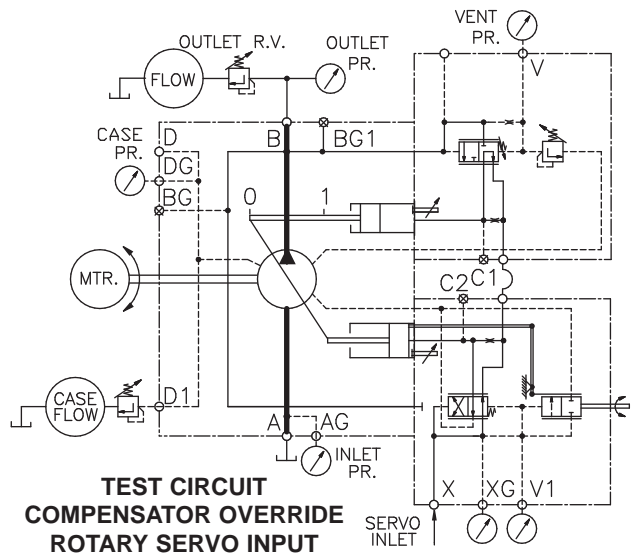
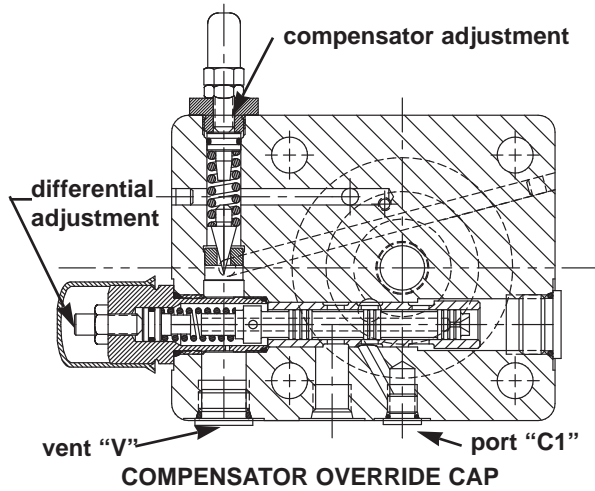

COMPENSATOR TEST

Outlet relief valve should be set to minimum pressure.

If the pump contains a servo, hydraulic or electrohydraulic stroker control, test that control first, (pg. 64, 68 or 69) then set the control to give full stroke on the pump.

Install gages on outlet pressure and "V" capable of measuring pressure difference to 10 psi, 0,69 bar. Gages must be adequate for outlet pressure.

If testing pump with load sensing compensator or torque limiter control, the test stand must include a gage on the line from "LS" capable of measuring pressure difference to 10 psi, 0,69 bar and the other components shown in the load sensing test circuit. Open speed control valve fully, and close load valve to first test the compensator function.

Turn compensator adjustment screw CCW until there is no contact with spring, then adjust 1/2 turn CW after contact is made with spring.

Turn differential adjustment screw out till there is no contact with spring, then in 1-1/2 turns. (Approximately one nut width exposure of screw thread)

Start prime mover. Observe for correct rotation. Pump should be at full displacement at minimum pressure.

Adjust outlet relief valve until compensator destrokes pump to zero displacement. Compensator pressure should be approximately 1000 psi, 69 bar with the 1/2 turn pre-adjustment. Note: With servo type controls, minimum compensator override pressure will be higher, depending on the servo supply pressure. See chart below.

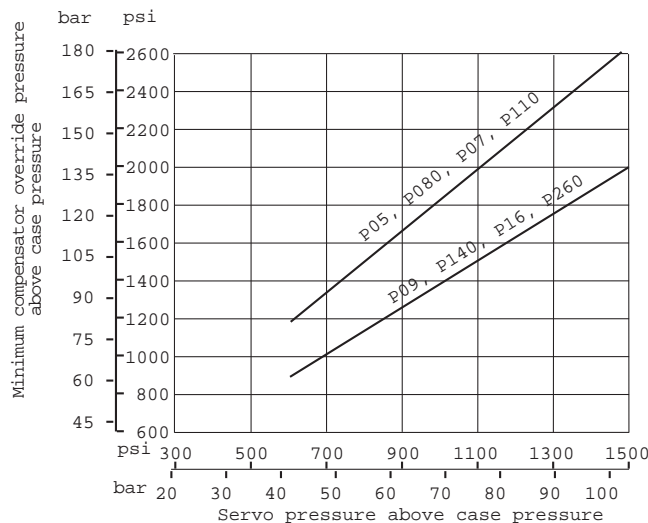

Raise compensator from minimum to maximum outlet pressure. At each condition, increase the outlet pressure until the pump fully de-strokes. At no time should the outlet pressure vary over 150 psi, 10,3 bar from the compensator setting. The control should be steady and stable at all conditions.

Calculate compensator leakage by subtracting leakage flow at full flow from leakage flow fully compensated. Compensator leakage: 5 gpm, 18.9 lpm. max.

Reduce outlet pressure to 150 psi, 10,3 bar below the compensator setting. Pump should return to full stroke. Repeat two or more times. Compensator settings should be repeatable. Proceed to **FINAL PUMP TEST (pg. 75)**, or **LOAD SENSING TEST (below)** if applicable.

LOAD SENSING TEST

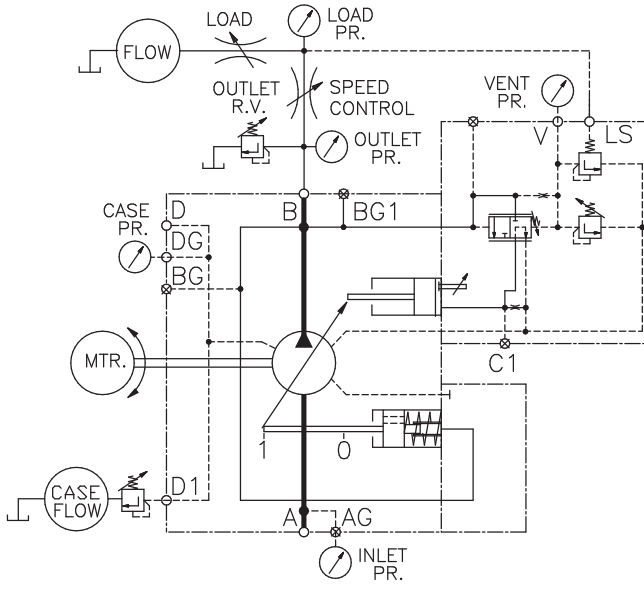

**TEST CIRCUIT
LOAD SENSING**

Caution: Load sensing control is limited to 5000 psi, 345 bar maximum pressure.

Pump should be connected to speed control valve, load sensing line and load valve as shown.

Close the speed control valve. Check the pressure difference from outlet pressure to load pressure. Using the differential adjustment, set this pressure difference to 450 psi ± 25 psi, 31,0 ± 1,72 bar or shop order requirement. Caution: Too low or too high a setting will cause the control to malfunction. Install cap on differential adjustment.

Fully open the speed control valve. Set the compensator to 3000 psi, 207 bar, and 5000 psi, 345 bar. (One turn of adjustment equals approximately 2000 psi, 138 bar.) At each condition, increase the outlet pressure by closing the load valve until the pump fully de-strokes. At no time should the outlet pressure vary more than 150 psi, 10,3 bar from the compensator setting. The control should be steady and stable at all conditions.

With pump at full flow and 5000 psi, 345 bar outlet pressure, close speed control valve till flow reduces slightly. Note flow. Open load valve slowly, to drop outlet pressure toward minimum. Flow shall remain constant within 10 gpm, 37,8 lpm at all pressures.

Adjust the speed control valve till flow is at a low value. Note flow. Raise and lower outlet pressure by closing and opening the load valve. Flow shall remain constant within 10 gpm, 37,8 lpm. Proceed to **FINAL PUMP TEST (pg. 75)**.

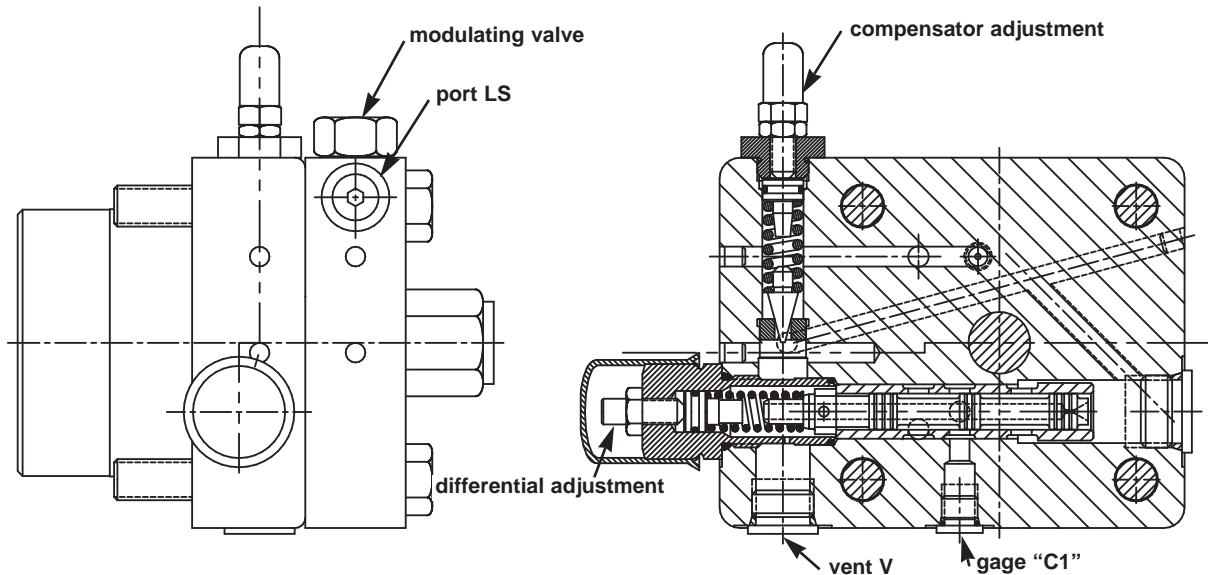

LOAD SENSING CONTROL

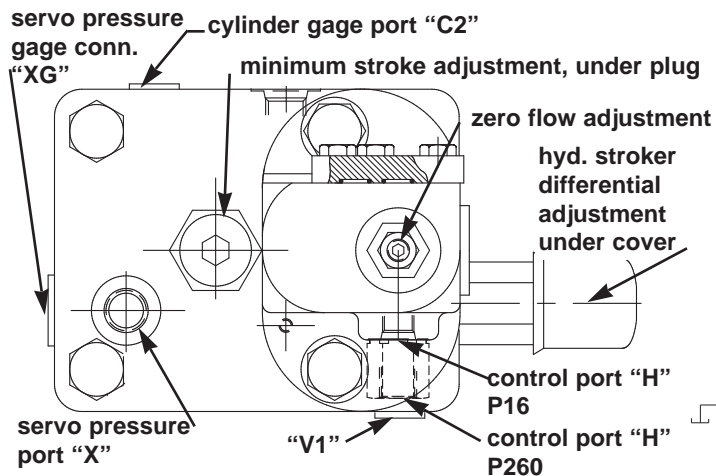

HYDRAULIC STROKER CAP

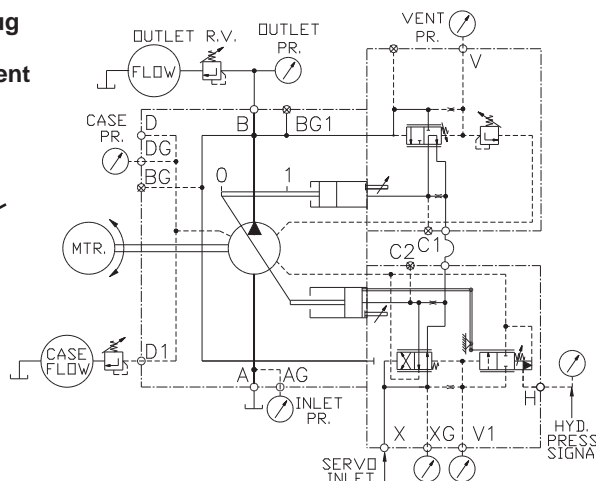

TEST CIRCUIT
 HYDRAULIC STROKER
 COMPENSATOR OVERRIDE

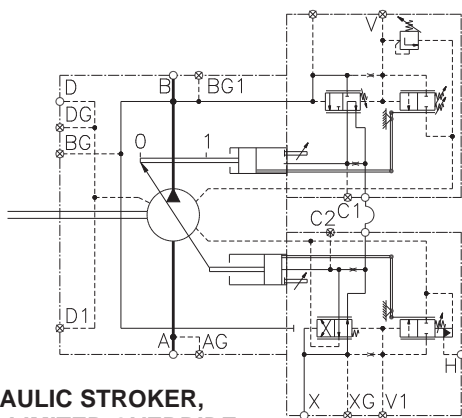

HYDRAULIC STROKER,
 TORQUE LIMITER OVERRIDE

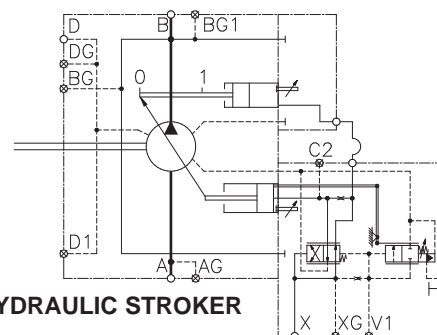

HYDRAULIC STROKER

HYDRAULIC STROKER TEST

Before testing hydraulic stroker, disable the compensator or torque limiter override, if applicable, by turning the compensator differential adjustment fully in. (See compensator or torque limiter test). **CAUTION:** System must contain a relief valve to limit outlet pressure. Outlet relief valve should be set to minimum pressure.

Plumb servo supply (5 gpm, 19 lpm minimum at 1500 psi, 103 bar maximum) to control port "X". Plumb adjustable hydraulic pressure (50 to 350 psi, 3,45 to 24 bar) to control port "H".

Thread minimum stroke adjustment screw so that pump is on stroke.

Install gages on servo pressure gage port XG and on gage port V1, capable of measuring pressure difference to 10 psi, 0,69 bar. Gages must be adequate for servo pressure.

Turn hydraulic stroker differential adjustment screw in till solid, then out 7 turns.

Start pump. Apply hydraulic control signal to port "H" till pump is at some stroke between zero and full. Adjust differential pressure by adjusting the differential screw until the difference in pressure readings between port XG and V1 is 250 psi, 17,2 bar. Install cover over differential adjustment.

Set signal pressure to 50 psi, 3,45 bar. Back out zero volume stop and set zero flow adjustment until pump is at zero stroke. Lock both adjustments in place.

Slowly increase and decrease signal pressure between 0 and 275 psi, 19,0 bar several times at minimum and maximum operating outlet pressure. Pump stroke should follow control pressure smoothly and proportionally. Rapidly adjust signal pressure between 0 and 275 psi, 19,0 bar. Full to zero or zero to full stroke should be achieved in no more than 0,3 second.

Proceed to **COMPENSATOR TEST (pg. 66)**, **TORQUE LIMITER TEST (pg. 70)**, or **FINAL PUMP TEST (pg. 75)**, as applicable.

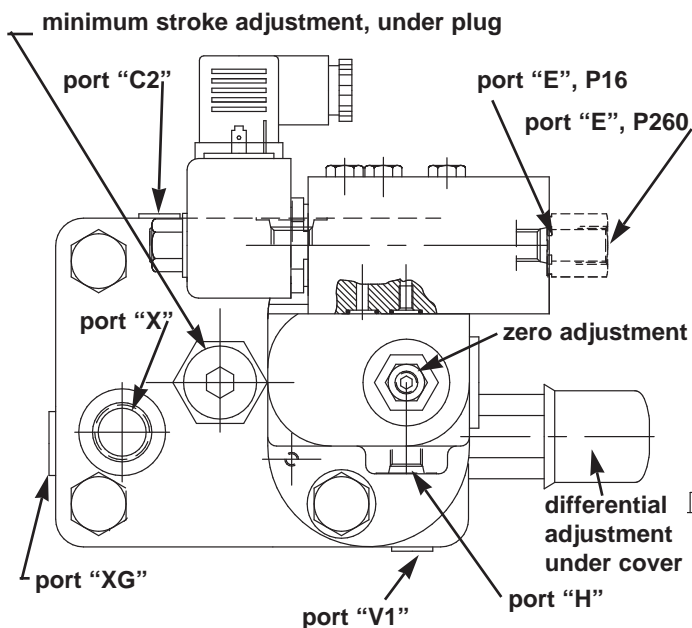

ELECTROHYDRAULIC STROKER CAP

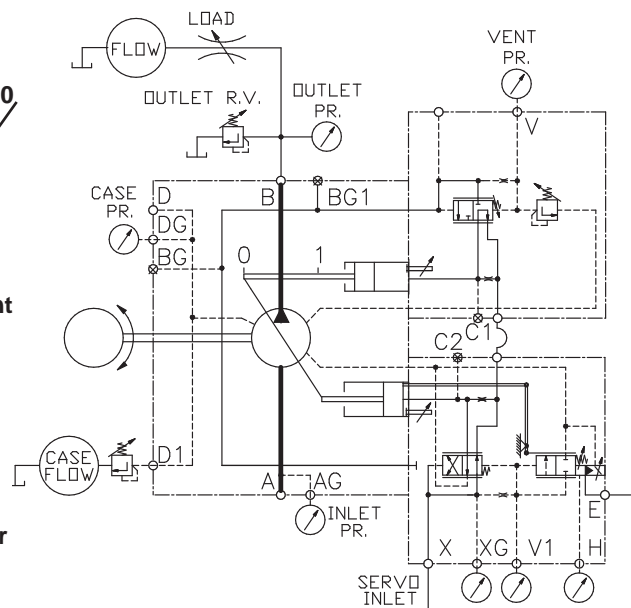

**TEST CIRCUIT
ELECTROHYDRAULIC STROKER
COMPENSATOR OVERRIDE**

ELECTROHYDRAULIC STROKER TEST

Before testing electrohydraulic stroker, disable the compensator or torque limiter override, if applicable, by turning the compensator differential adjustment fully in. (See compensator or torque limiter test) **CAUTION:** System must contain a relief valve to limit outlet pressure. Outlet relief valve should be set to minimum pressure.

Plumb servo supply (5 gpm, 19 lpm minimum at 1500 psi, 103 bar maximum) to control port "X", and to the electric stroker port, "E"

Install gages on servo pressure gage port XG and on gage port V1, capable of measuring pressure difference to 10 psi, 0,69 bar. Gages must be adequate for servo pressure.

Thread zero volume stop screw so that pump is on stroke.

Turn electrohydraulic stroker differential adjustment screw in till solid, then 7 turns out.

Start pump. Observe for correct rotation. Adjust current to proportional valve till pump is at some stroke between zero and full. Adjust differential pressure by adjusting the differential screw until the difference in pressure readings between port XG and V1 is 250 psi, 17,2 bar. Install cover over differential adjustment.

Adjust current to 170 mA. Back out zero volume stop and set zero flow adjustment until pump is at zero stroke. Lock both adjustments in place. If pump fails to respond, measure pressure at port "H", pressure to be 50 psi, 3,45 bar minimum, for 170 mA current with 24 V. coil. Remove gage after checking, to avoid unstable operation.

Increase current to 300 mA. Pump should go to full stroke. Set max. volume screw on opposite control cap for full stroke.

Increase and decrease the amperage between 0 and 300 mA several times at minimum to maximum outlet pressure. Pump stroke should follow amperage smoothly and proportionally. Full to zero or zero to full stroke should be achieved in .3 second. Adjust amperage up to 275 mA from zero stroke, then adjust down from full stroke to 275 mA. The flows at the two 275 mA settings shall not vary more than 10 gpm, 37,8 lpm from each other.

Proceed to **COMPENSATOR TEST (pg. 66)**, **TORQUE LIMITER TEST (pg. 70)**, or **FINAL PUMP TEST (pg. 75)**, as applicable.

TORQUE LIMITER AND TORQUE LIMITER OVERRIDE TEST

The torque limiter design is a compensator with a means of varying pump stroke with pressure in this manner: The compensator vent port applies pressure to a pin. The pin moves against two independently adjustable springs. A sleeve, sliding over the pin, opens or closes the vent passage, to control the compensator pressure. The sleeve is connected through a linkage to the control piston. As pressure increases, the stroke must reduce, and vice versa, to provide approximate constant torque.

Install gages on outlet pressure and "V" capable of measuring pressure difference to 10 psi, 0,69 bar. Gages must be adequate for outlet pressure.

Turn compensator adjustment screw out to remove spring load, then 1/2 turn in.

Turn differential adjustment screw out till there is no contact with spring, then in 1-1/2 turns. (Approximately one nut width exposure of screw thread)

If the pump contains a servo, hydraulic or electrohydraulic stroker control, test that control first (pg. 64, 68 or 69) then set the control to give full stroke on the pump. **CAUTION:** System must contain a relief valve to limit outlet pressure. Outlet relief valve should be set at 500 psi, 34,5 bar.

To test and set compensator function, disable torque limiter in this manner: Back out high pressure flow adjustment screw (inner) to remove all load. Turn in high flow pressure adjustment screw (outer) to go solid. Caution! do not apply over 10 in.*lb, 1,2 Nm torque to avoid damage to internal parts!

Start prime mover with outlet relief set at 500 psi, 34,5 bar. Apply a load to the pump.

Pump should be at full displacement at 500 psi, 34,5 bar.

Increase outlet pressure until compensator de-strokes pump to zero displacement. Note minimum compensated pressure versus servo pressure in chart on page 66. Set compensator to minimum compensated pressure.

Adjust compensator differential spool pressure to 250 psi, 17,2 bar. This is accomplished by adjusting the differential screw until the difference in pressure readings between the outlet pressure and compensator vent "V" gages installed in the compensator cap is 250 psi, 17,2 bar. Install cover over differential adjustment.

maximum volume stop

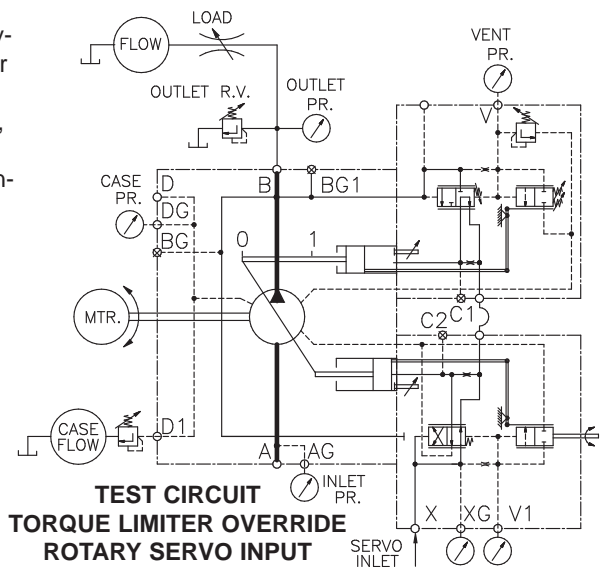
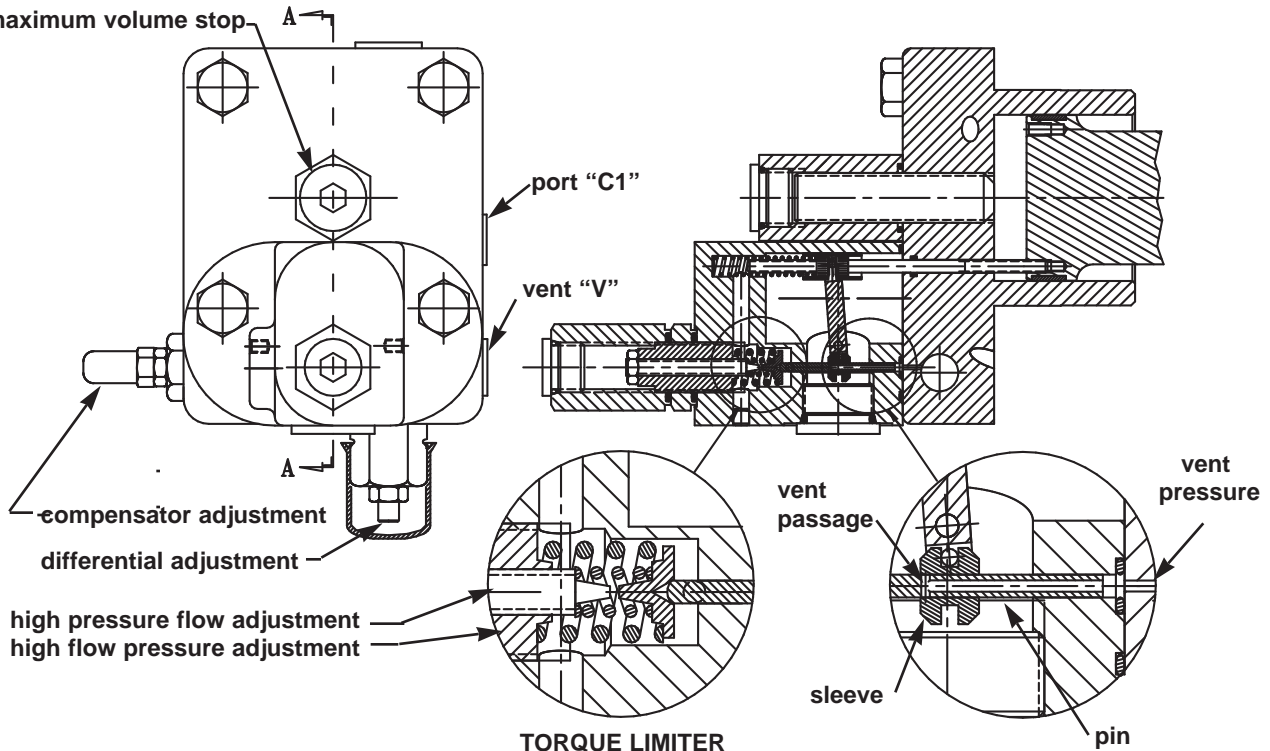

**TEST CIRCUIT
TORQUE LIMITER OVERRIDE
ROTARY SERVO INPUT**

Set the compensator to 3000 psi, 207 bar, 6000 psi, 414 bar, and 7250 psi, 500 bar. (One turn approximately equals 2000 psi, 138 bar)

At each condition, increase the outlet pressure until the pump fully de-strokes. At no time should the outlet pressure vary more than 150 psi, 10,3 bar from the compensator setting. The control should be steady and stable at all conditions.

Reduce outlet pressure below the compensator setting. Pump should return to full stroke. Repeat two or more times. Compensator setting should be repeatable.

Set compensator adjustment to at least 500 psi, 34,5 bar above the maximum outlet pressure.

TORQUE LIMITER TEST AND ADJUSTMENT

Set the torque limiter by using the formula:

$$HP = P \cdot Q / (\text{Eff.} \cdot 1714), \text{ or } P = HP(\text{Eff.} \cdot 1714) / Q, \text{ or } Q = HP(\text{Eff.} \cdot 1714) / P$$

where P = Pressure in psi

Q = flow in GPM

Eff. = overall efficiency

$$\text{or } kW = P \cdot Q / (\text{Eff.} \cdot 600), \text{ or } P = kW(\text{Eff.} \cdot 600) / Q, \text{ or } Q = kW(\text{Eff.} \cdot 600) / P$$

where P = pressure in Bar

Q = flow in lpm

Eff. = overall efficiency

calculate these two values:

- a. Outlet pressure at full pump flow.
- b. Pump flow at full outlet pressure.

1. Set outlet to pressure (a) calculated above. Back out high pressure flow adjusting screw (inner screw) to remove all load. Set the high flow pressure adjusting screw (outer) so that pump just commences to de-stroke.

2. Set the system to the required maximum outlet pressure. Set high pressure flow adjusting screw (inner) to obtain the calculated flow (b) at full outlet pressure.

Note: Electric motor current or engine load may be used instead of calculated flows to set power. In step 1, set the high flow adjustment to achieve the rated motor current or engine load. In step 2, set the high pressure adjustment to achieve the rated motor current or engine load.

Proceed to **FINAL PUMP TEST (pg. 75)**

LOAD SENSING TORQUE LIMITER

Caution: Load sensing control is limited to 5000 psi, 345 bar maximum pressure.

Pump should be connected to speed control valve, load sensing line and load valve as shown.

Install gages on outlet pressure and "V" capable of measuring pressure difference to 10 psi, 0,69 bar. Gages must be adequate for outlet pressure.

Turn compensator adjustment screw out to remove spring load, then 1/2 turn in.

Turn differential adjustment screw out till there is no contact with spring, then in 1-1/2 turns. (Approximately one nut width exposure of screw thread)

To test and set compensator and load sensing function, disable torque limiter in this manner: Back out high pressure flow adjustment screw (inner) to remove all load. Turn in high flow pressure adjustment screw (outer) to go solid. Caution! do not apply over 10 in.*lb, 1,2 Nm torque to avoid damage to internal parts!

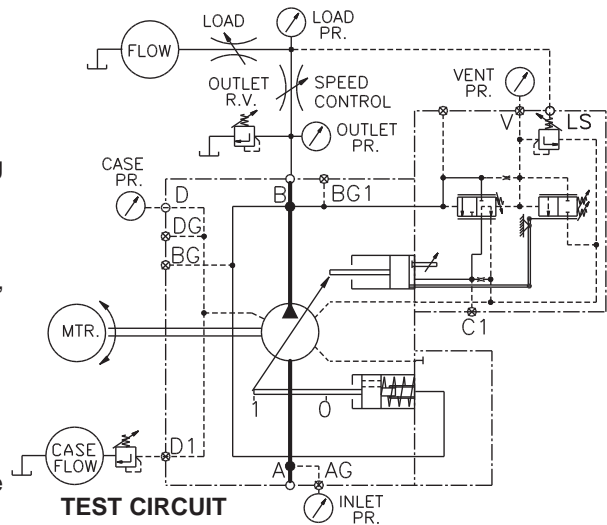

**TEST CIRCUIT
LOAD SENSING
TORQUE LIMITER**

Start prime mover with outlet relief set at 500 psi, 34,5 bar. Apply a load to the pump.

Pump should be at full displacement at 500 psi, 34,5 bar.

Increase outlet pressure until compensator de-strokes pump to zero displacement. Note minimum compensated pressure versus servo pressure in chart on page 58. Set compensator to minimum compensated pressure.

Adjust compensator differential spool pressure to 250 psi, 17,2 bar. This is accomplished by adjusting the differential screw until the difference in pressure readings between the outlet pressure and compensator vent "V" gages installed in the compensator cap is 250 psi, 17,2 bar. Install cover over differential adjustment.

Close the speed control valve. Check the pressure difference from outlet pressure to load pressure. Using the differential adjustment, set this pressure difference to 450 psi ± 25 psi, 31,0 ± 1,72 bar or shop order requirement. Caution: Too low or too high a setting will cause the control to malfunction. Install cap on differential adjustment.

Fully open the speed control valve. Set the compensator to 3000 psi, 207 bar, and 5000 psi, 345 bar. (One turn of adjustment equals approximately 2000 psi, 138 bar.) At each condition, increase the outlet pressure by closing the load valve until the pump fully de-strokes. At no time should the outlet pressure vary more than 150 psi, 10,3 bar from the compensator setting. The control should be steady and stable at all conditions.

With pump at full flow and 5000 psi, 345 bar outlet pressure, close speed control valve till flow reduces slightly. Note flow.

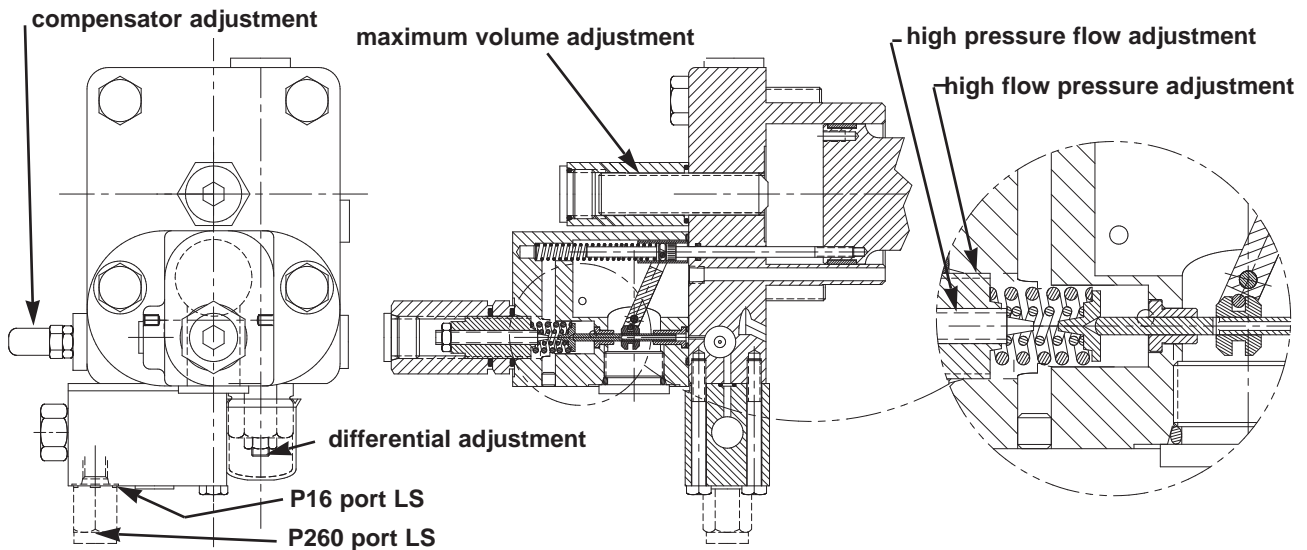

Open load valve slowly, to drop outlet pressure toward minimum. Flow shall remain constant within 10 gpm, 37,8 lpm at all pressures.

Adjust the speed control valve till flow is at a low value. Note flow. Raise and lower outlet pressure by closing and opening the load valve. Flow shall remain constant within 10 gpm, 37,8 lpm.

Fully open the speed control valve.

Set the torque limiter by using the formula:

$$HP = P \cdot Q / (\text{Eff} \cdot 1714), \text{ or } P = HP(\text{Eff} \cdot 1714) / Q, \text{ or } Q = HP(\text{Eff} \cdot 1714) / P$$

where P = Pressure in psi

Q = flow in GPM

Eff. = overall efficiency

$$\text{or } kW = P \cdot Q / (\text{Eff} \cdot 600), \text{ or } P = kW(\text{Eff} \cdot 600) / Q, \text{ or } Q = kW(\text{Eff} \cdot 600) / P$$

where P = pressure in Bar

Q = flow in lpm

Eff. = overall efficiency

calculate these two values:

- a. Outlet pressure at full pump flow.
- b. Pump flow at full outlet pressure.

1. Set outlet to pressure (a) calculated above. Back out high pressure flow adjusting screw (inner screw) to remove all load. Set the high flow pressure adjusting screw (outer) so that pump just commences to de-stroke.

2. Set the system to the required maximum outlet pressure. Set high pressure flow adjusting screw (inner) to obtain the calculated flow (b) at full outlet pressure.

Note: Electric motor current or engine load may be used instead of calculated flows to set power. In step 1, set the high flow adjustment to achieve the rated motor current or engine load. In step 2, set the high pressure adjustment to achieve the rated motor current or engine load.

Proceed to **FINAL PUMP TEST (pg. 75)**

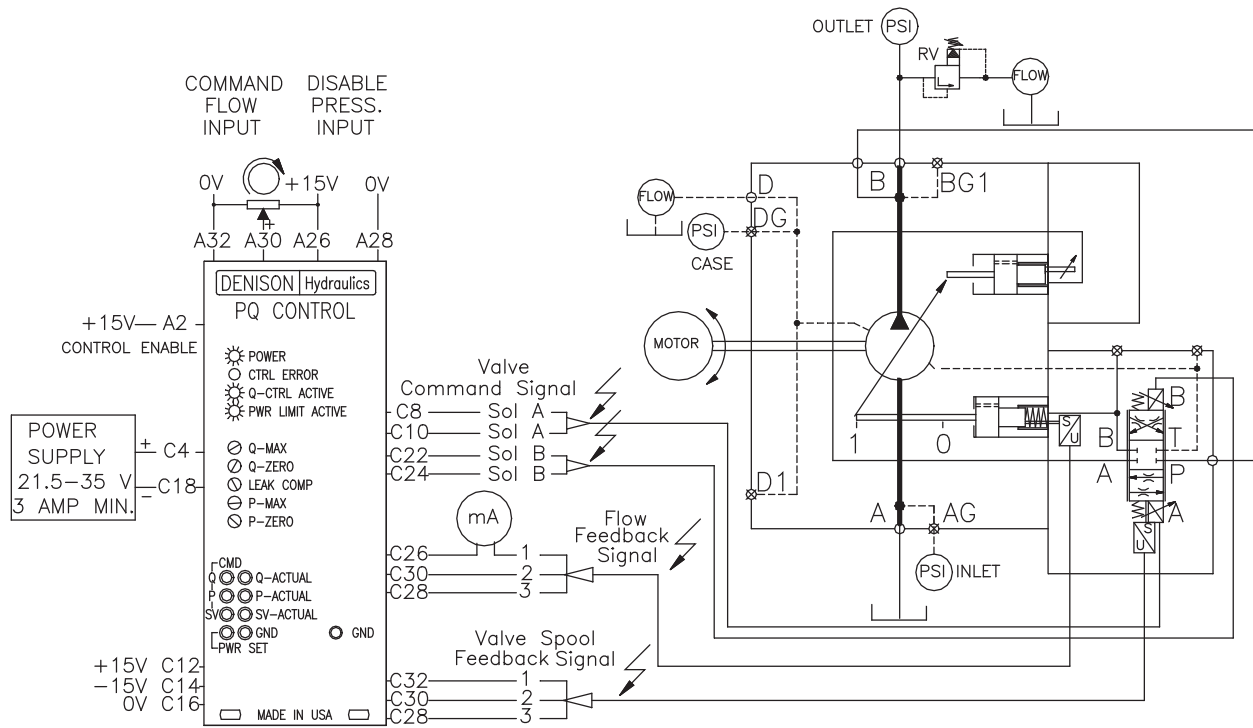

PRESSURE/FLOW (PQ) CONTROL

Connect PQ control driver card 020-14133 to pump as indicated.

1. Adjust maximum volume stop to full displacement by backing off screw CCW until there is no contact with control piston.
2. Set test stand relief valve at 500 psi. Jog electric motor to verify correct rotation. Start electric motor. With power off to the control, pump should be at full displacement at 500 psi, about 120 gpm.
3. Apply power to control. With command pot at 0 volts, the pump should go to zero displacement, at approximately 300 psi.
4. Check mA reading of flow feedback signal. At zero displacement, flow feedback signal shall be 6.67 mA +/- 0.2 mA. If incorrect, adjust left side screw on rear of flow feedback lvdt until output is within range.
5. Rotate command from 0 to 10 volts to 0 volts. Pump shall stroke from zero to full stroke to zero stroke as signal goes from 0 to 10 to 0 volts. Proceed to **Final Pump Test, (pg. 75)**.

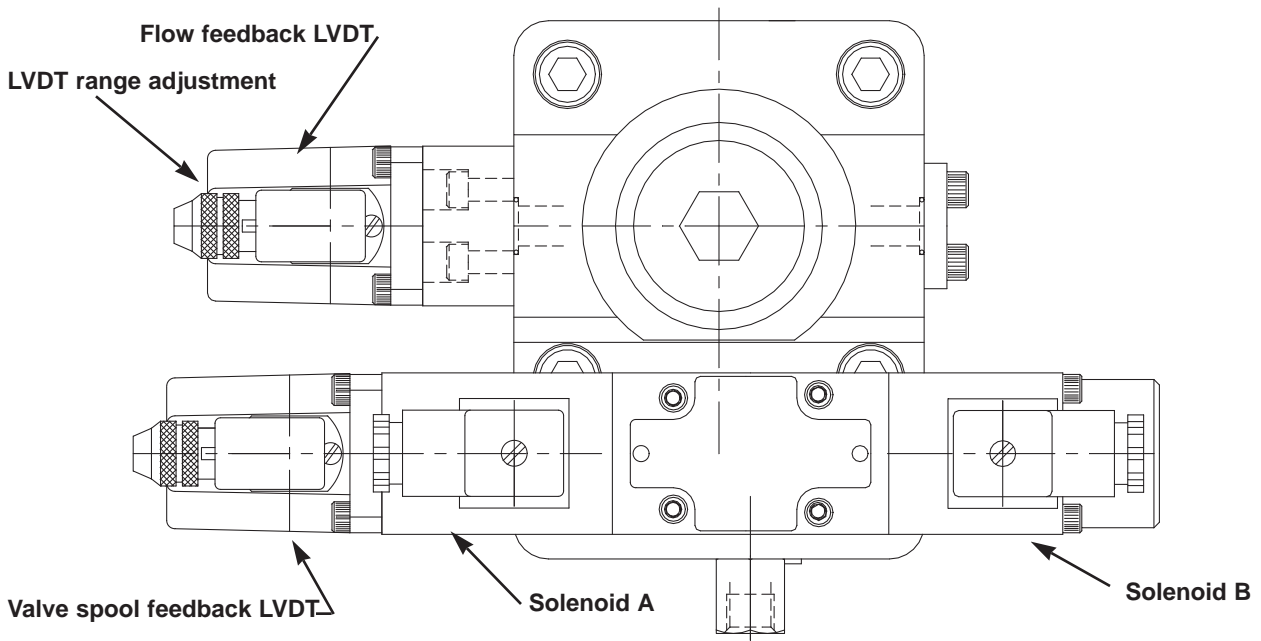

FINAL PUMP TEST

Operate the pump with the following outlet pressures for the times indicated.

3000 psi ± 100 psi, 207 bar ± 6,9 bar	2 minutes minimum
5000 psi ± 100 psi, 345 bar ± 6,9 bar	1 minute minimum
6000 psi ± 100 psi, 414 bar ± 6,9 bar	1 minute minimum

While breaking in, destroke the pump several times at each pressure setting, by either reducing compensator setting, servo/stroker command, or Q command to PQ control, as applicable.

FULL STROKE REQUIREMENTS AT 6000 PSI, 414 BAR

PUMP SERIES	MINIMUM OUTPUT FLOW		MAX CASE DRAIN FLOW	
	GPM	LPM	GPM	LPM
P16/P260 @ 1750 RPM	115.0	435	7.5	28,4
P16/P260 @ 1450 RPM	94.5	358	7.5	28,4

Raise compensator setting from minimum to maximum outlet pressure. **Caution:** Load sensing control is limited to 5000 psi, 345 bar maximum pressure.

At each condition, increase the outlet pressure until the pump fully de-strokes. At no time should the outlet pressure vary over 150 psi, 10,3 bar from full to zero flow. The control should be steady and stable at all conditions.

Reduce outlet pressure to 150 psi, 10,3 bar below the compensator setting. Pump should return to full stroke. Repeat two or more times. Compensator settings should be repeatable. Set compensator at 1000 psi ± 100 psi, 69 bar ± 6,9 bar standard, or desired value.

Check for leaks. NO external leaks are permitted. The shaft seal can be dry or damp. (Damp: A very small amount of oil at the seal and shaft joint, but NOT running onto the seal face).

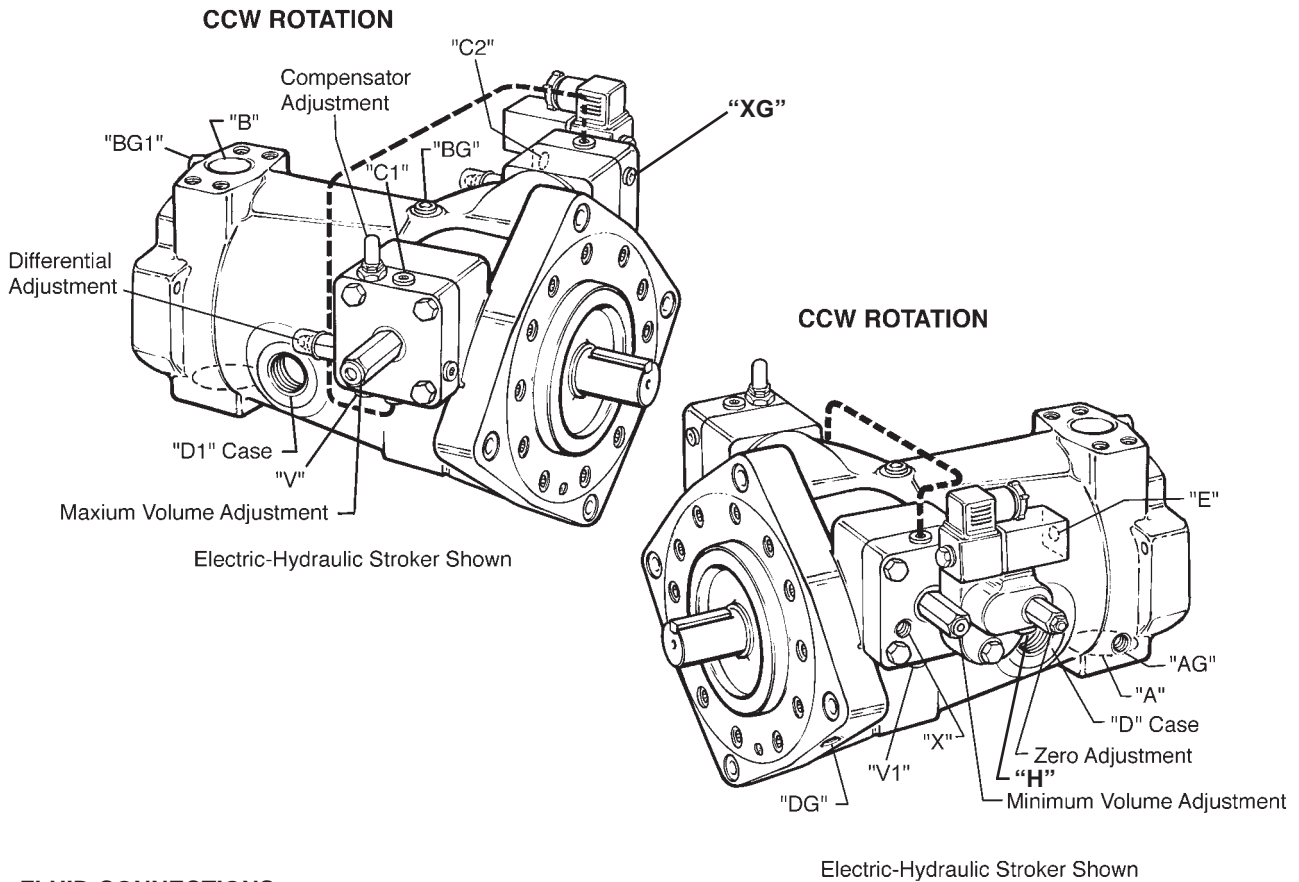

FLUID CONNECTIONS

DESCRIPTION	P16 C MOD	P260 C MOD
PORT AINLET	3-1/2 SAE CODE 61 5/8-11 SCREWS	3-1/2 SAE CODE 61 M16-2 SCREWS
PORT BSYSTEM	1-1/2 SAE CODE 62 5/8-11 SCREWS	1-1/2 SAE CODE 62 M16-2 SCREWS
PORT C1OFF-STROKE CYL. GAGE	SAE-4	1/4 BSPP
PORT C2ON-STROKE CYL. GAGE	SAE-4	1/4 BSPP
PORT DCASE DRAIN	SAE-24	1-1/2 BSPP
PORT D1CASE DRAIN	SAE-24	1-1/2 BSPP
PORT DG.....DRAIN GAGE, AIR BLEED PORT	SAE-4	1/4 BSPP
PORT AG.....INLET GAGE	SAE-4	1/4 BSPP
PORT BG.....SYSTEM GAGE	SAE-4	1/4 BSPP
PORT BG1....ALT. SYS. GAGE	SAE-6	1/4 BSPP
PORT EELECTROHYDRAULIC STROKER SERVO SUPPLY	SAE-4	1/4 BSPP
PORT HHYDRAULIC STROKER SIGNAL	SAE-4	1/4 BSPP
PORT LSLOAD SENSING LINE	SAE-4	1/4 BSPP
PORT VCOMPENSATOR, TORQUE LIMITER, LOAD SENSING VENT	SAE-8	3/8 BSPP
PORT VOVERRIDE COMP, OVERRIDE TORQUE LIMITER VENT	SAE-4	1/4 BSPP
PORT V1SERVO VENT	SAE-4	1/4 BSPP
PORT XSERVO SUPPLY	SAE-8	3/8 BSPP
PORT XG.....SERVO GAGE	SAE-10	1/2 BSPP

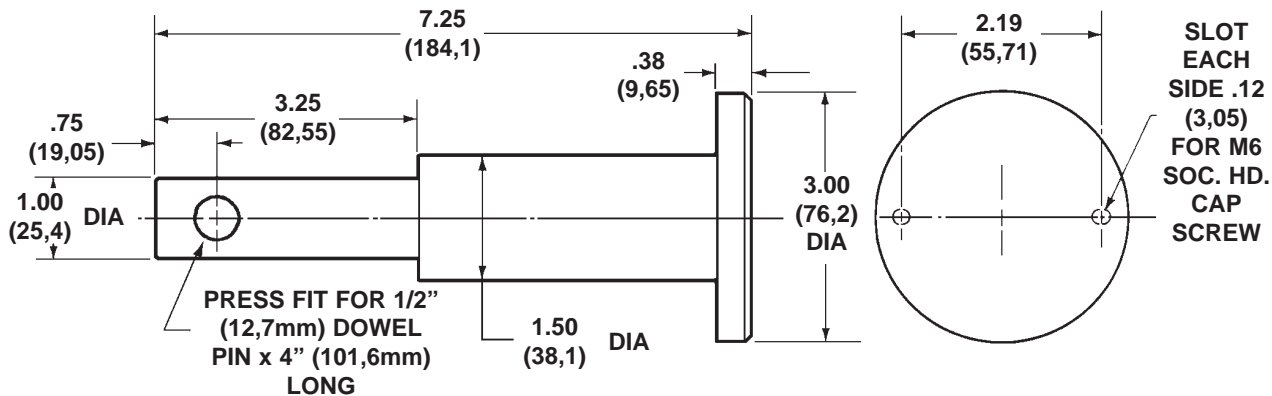

T-1
(Lifting tool)
 Barrel & inner race assembly

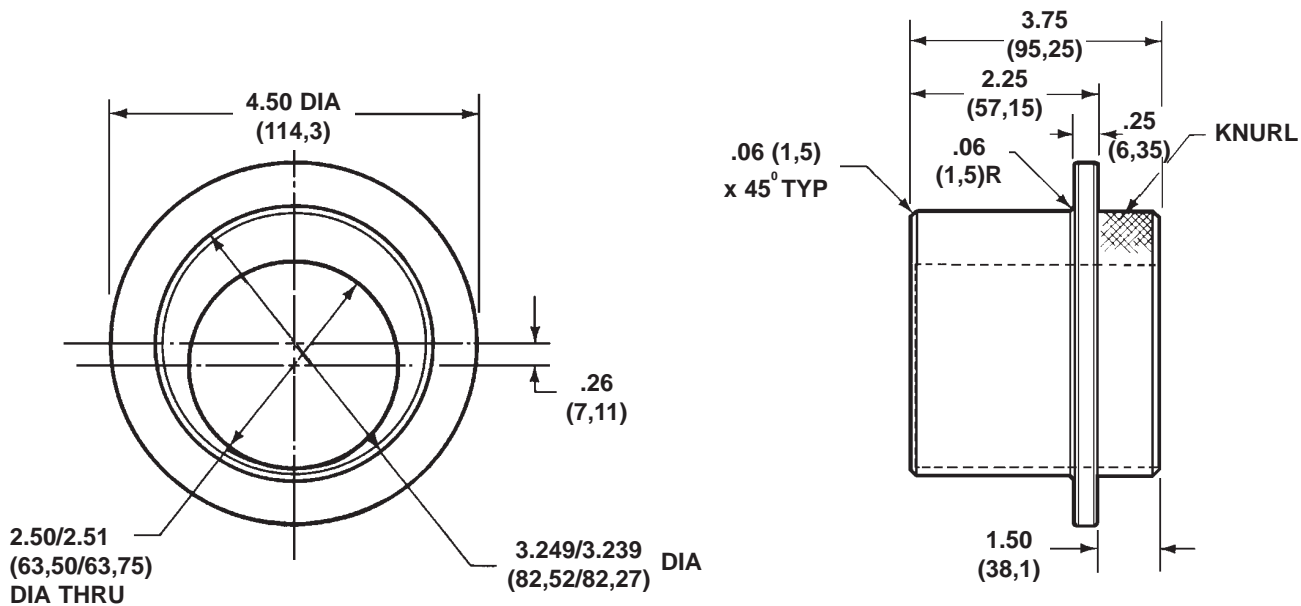

T-2
(Positioning tool)
 For positioning the stroking piston
 during cam installation
 (2 required)

T-3

(Installation tool)
Retainer & shaft bearing In cradle

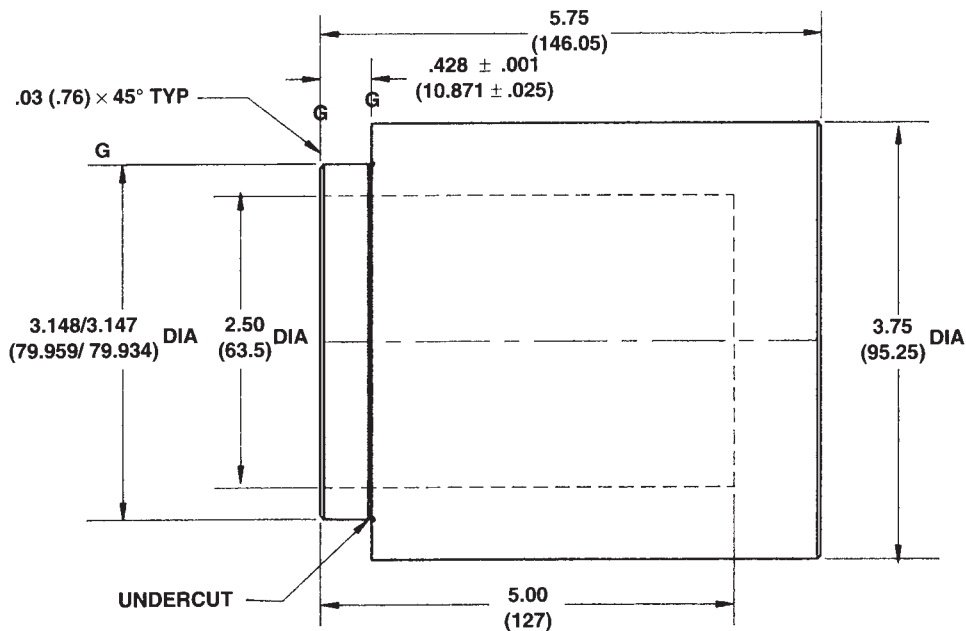

T-4

(Installation tool)
Shaft seal over shaft

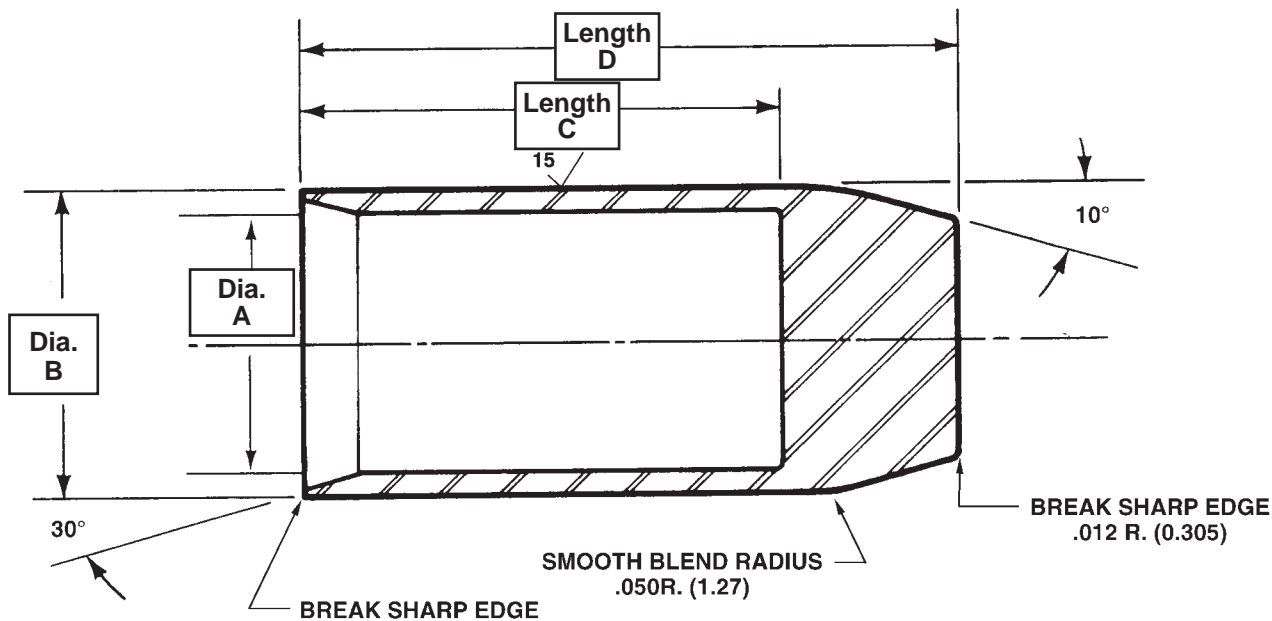

Shaft	A		B		C		D	
	in.	mm	in.	mm	in.	mm	in.	mm
P16 keyed	1.755/1.760	44,58/44,70	1.878/1.880	47,70/47,75	3.00	76,2	4.50	114,3
P16 splined	1.725/1.730	43,82/43,94	1.878/1.880	47,70/47,75	3.00	76,2	4.50	114,3
P16 splined (Hi-torque)	2.005/2.010	50,93/51,05	2,130/2,135	54,10/54,23	3.50	88,9	5.00	127,0
P260 ISO keyed/splined	1,974/1,976	50,14/50,19	2,130/2,135	54,10/54,23	3,67	93,2	5,17	131,3
P260 DIN keyed/splined	2.351/2.353	59,72/59,77	2.505/2.510	63,63/63,75	4.63	117,6	6.13	155,7

TYPICAL CHARACTERISTICS

Specification	Term	P16H	P260H	P16Q	P260Q
• displacement at max. angle	in³/rev.	16	16	16	16
	cm³/rev	262,2	262,2	262,2	262,2
• pressure continuous	psi	6000	6000	6000	6000
	bar	420	420	420	420
• pressure intermittent (not to exceed 6 sec./minute)	psi	7250	7250	7250	7250
	bar	500	500	500	500
• speed, @ atmospheric inlet	rpm	1850	1850	1850	1850
	rpm	2500	2500	1850	1850
• rotating inertia	lbs/in²	349	349	360	360
	kg.m²	0,102	0,102	0,105	0,105
• compensator response off-stroke	sec.	0.100	0,100	0.100	0,100
	sec.	0.150	0,150	0.150	0,150
• compensator adjustment	psi/turn	2000	2000	2000	2000
	bar/turn	138	138	138	138
• minimum compensating pressure (comp, torque limiter) ..	psi	200*	200*	200*	200*
	bar	13,8*	13,8*	13,8*	13,8*
• minimum compensating pressure (override controls) (at 700 psi, 48,3 bar servo)	psi	1350*	1350*	1350*	1350*
	bar	93*	93*	93*	93*
• typ. servo & stoker response @ 700 psi, 48,3 bar servo pressure, zero to full stroke and vice versa	sec.	<0.35	<0,35	<0.35	<0,35
• servo flow required for this response	gpm	5	5	5	5
	l/min	19	19	19	19
• minimum servo pressure	psi	700	700	700	700
	bar	48	48	48	48
• maximum servo pressure	psi	1500	1500	1500	1500
	bar	103	103	103	103
• PQ control response (10% to 90% & 90% to 10% flow) ..	sec.	<.09	<.09	<.09	<.09
• electric stoker nominal coil resistance (24v. coil)	ohms	41	41	41	41
• electric stoker nominal coil resistance (12v. coil)	ohms	10	10	10	10
• handwheel turns, full to zero stroke	turns	10	10	10	10
• torque to turn handwheel @ 1000 psi,, 70 bar	in-lbs	150	150	150	150
	Nm	17	17	17	17
• torque to turn handwheel @ 7250 psi,, 500 bar	in-lbs	350	350	350	350
	Nm	40	40	40	40
• rotary servo shaft rotation, 0 to full stroke	degrees	65-70	65-70	65-70	65-70
• torque to turn rotary servo shaft	in-lbs	20	20	20	20
	Nm	2,3	2,3	2,3	2,3
• maximum/minimum case pressure (continuous)	psi	25/3	25/3	25/3	25/3
	bar	1,7/0,2	1,7/0,2	1,7/0,2	1,7/0,2
• maximum/minimum case pressure (intermittent)	psi	50/3	50/3	50/3	50/3
	bar	3,4/0,2	3,4/0,2	3,4/0,2	3,4/0,2
• input mounting-4 bolt flange	SAE	165-4 (E)		165-4 (E)	
	ISO 3019/2		250 B4HW		250 B4HW
• input shaft, keyed	SAE	44-1 (E)		44-1(E)	
• input shaft, splined.....	SAE	44-4 (E)		44-4 (E)	
• input shaft, keyed ISO 3019/2	ISO		G50N		G50N
• input shaft, splined ISO 3019/2	ISO		K50N		K50N
• input shaft, keyed DIN	DIN		6885 60 mm		6885 60 mm
• input shaft, splined DIN	DIN		5480 60 mm		5480 60 mm
• input shaft high torque splined	SAE	50-4 (F)		50-4 (F)	
• weight	pounds	325	325	325	325
	kg.	147,4	147,4	147,4	147,4

*plus case pressure

GENERAL

The **DENISON HYDRAULICS** P16/P260 Series is a variable displacement open circuit axial piston pump with advance pumping and control concepts.

MOUNTING

This pump is designed to operate in any position. The pump shaft must be in alignment with the shaft of the prime mover and should be checked with a dial indicator. The mounting pad or adapter into which the pump pilots must be concentric with the pump shaft to prevent bearing failure. This concentricity is particularly important if the shaft is rigidly connected to the driven load without a flexible coupling.

SHAFT INFORMATION

Splined: The shafts will accept a maximum misalignment of .006", 0.15 mm TIR. Angular misalignment at the male and female spline axis must be less than 0.001 in. per in. radius, 0.001 mm per mm. The coupling interface must be lubricated. DENISON HYDRAULICS recommends lithium molydisulfide or similar grease. The female coupling should be hardened to 27-34 Rc. The P16 must conform to SAE J498B (1971) class 1 flat root side fit, the P260 must conform to either ISO 4156 fillet root side fit module 2,50 or DIN 5480 (9H) flat root side fit module 2.00 as applicable

Keyed: High strength heat treated keys must be used. Replacement keys must be hardened to 27-34 Rc. The key corners must be chamfered .030"-.040", 0.75-1.00 mm at 45° to clear radii that exist in the keyway.

PORTING INFORMATION

See port identification section for port locations and sizes.

The maximum case pressure is 25 psi, 1.7 bar continuous, 50 psi, 3.4 bar intermittent. Case pressures must never exceed inlet pressure by more than 25 psi, 1.7 bar. When connecting case drain line make certain that drain plumbing passes above highest point of the pump before returning to the reservoir, if not, install a 5 psi, 0.3 bar case pressure check valve to be certain the case is filled with oil at all times.

The case leakage line must be of sufficient size to prevent back pressure in excess of 25 psi, 1.7 bar and returned to the reservoir below the surface of the oil as far from the supply suction as possible. All fluid lines, whether pipe, tubing, or hose must be of adequate size and strength to assure free flow through the pump. An undersize inlet line will prevent the pump from reaching full speed and torque. An undersized outlet line will create back pressure and cause improper operation. Flexible hose lines are recommended. If rigid piping is used, the workmanship must be accurate to eliminate strain on the pump port block or to the fluid connections. Sharp bends in the lines must be eliminated wherever possible. All system piping must be cleaned with solvent or equivalent before installing pump. Make sure the entire hydraulic system is free of dirt, lint, scale, or other foreign material.

CAUTION: Do not use galvanized pipe. Galvanized coating can flake off with continued use.

INLET CONDITIONS AT SEA LEVEL

SPEED	GAGE PRESSURE				ABS. PRESS.	
	psig	bar	in. hg	mm hg	psi	bar
1200	-3	-0.2	-6.1	-155	11.7	0.8
1500	-3	-0.2	-6.1	-155	11.7	0.8
1800	-0.8	-0.05	-1.6	-41	13.9	0.95
1850	0	0	0	0	14.7	1.01
*2100	4.3	0.30	8.8	224	19.0	1.30
*2500	12.2	0.82	24.8	630	26.9	1.83

*P16/P260 H only

NOTE: Inlet conditions apply for petroleum base fluids. Contact **DENISON HYDRAULICS** for inlet conditions with other fluids.

RECOMMENDED FLUIDS

See DENISON HYDRAULICS bulletin **SPO-AM305** for more information

MAINTENANCE

This pump is self-lubricating and preventative maintenance is limited to keeping system fluid clean by changing filters frequently. Keep all fittings and screws tight. Do not operate at pressures and speeds in excess of the recommended limit. If the pump does not operate properly, check the troubleshooting chart before attempting to overhaul the unit. Overhauling is relatively simple and may be accomplished by referring to the disassembly, rework limits of wear parts and assembly procedures.

FLUID CLEANLINESS

Fluid must be cleaned before adding to the system, and continuously during operation by filters that maintain a cleanliness level of NAS 1638 Class 8. This approximately corresponds to ISO 17/14.

DEFINITION & UNIT

<i>displacement</i>	$\text{in}^3/\text{rev} \times 16.387 = \text{cm}^3/\text{rev}$	$\text{cm}^3/\text{rev} \times 0.06102 = \text{in}^3/\text{rev}$
<i>flow</i>	$\text{gpm} \times 3.78 = \text{L}/\text{min}$	$\text{L}/\text{min} \times 0.2642 = \text{gpm}$
<i>power</i>	$\text{hp} \times 0.7457 = \text{kW}$	$\text{kW} \times 1.341 = \text{hp}$
<i>torque</i>	$\text{lb-ft} \times 1.3567 = \text{Nm}$	$\text{Nm} \times 0.7376 = \text{lb-ft}$
<i>pressure</i>	$\text{lbs}/\text{in}^2 \text{ (psi)} \times 0.06895 = \text{bar}$ $\text{lbs}/\text{in}^2 \text{ (psi)} \times 6.895 = \text{kPa}$	$\text{bar} \times 14.50 = \text{lbs}/\text{in}^2 \text{ (psi)}$ $\text{kPa} \times 0.1450 = \text{lbs}/\text{in}^2 \text{ (psi)}$
<i>weight</i>	$\text{lb} \times 0.4536 = \text{kg}$	$\text{kg} \times 2.205 = \text{lbs}$
<i>force</i>	$\text{lb} \times 4.448 = \text{N}$	$\text{N} \times 0.2248 = \text{lbs}$
<i>volume</i>	$\text{in}^3 \times 16.387 = \text{cm}^3$	$\text{cm}^3 \times 0.06102 = \text{in}^3$
<i>area</i>	$\text{in}^2 \times 6.452 = \text{cm}^2$	$\text{cm}^2 \times 0.1550 = \text{in}^2$
<i>length</i>	$\text{in} \times 25.4 = \text{mm}$	$\text{mm} \times 0.03937 = \text{in}$
<i>temperature</i>	$\text{degree F} - 32 = \text{C}$ 1.8	$1.8 \times \text{C} + 32 = \text{F}$
<i>viscosity</i>	$\text{cSt} \times 1.0 = \text{mm}^2/\text{sec}$ $\text{SSU} = \text{cSt} \times 4.25 + 14$	$\text{mm}^2/\text{sec} \times 1.0 = \text{cSt}$ $20 \text{ cSt} = 99 \text{ SSU}$

FLUID POWER FORMULAS

<i>Pump input torque</i>	<i>lbs. in.</i>	$\frac{\text{pressure}(\text{psi}) \times \text{displacement} (\text{in}^3/\text{rev})}{2\pi \times \text{mech. eff.}}$
<i>Pump input power</i>	<i>hp</i>	$\frac{\text{rpm} \times (\text{in}^3/\text{rev}) \times (\text{psi})}{395934 \times \text{overall eff.}}$
<i>Pump output flow</i>	<i>U.S. gpm</i>	$\frac{\text{rpm} \times (\text{in}^3/\text{rev}) \times \text{volumetric eff.}}{231}$
<i>Fluid motor speed</i>	<i>rpm</i>	$\frac{231 \times \text{flow rate}(\text{U.S. gpm}) \times \text{volumetric eff.}}{\text{displacement} (\text{in}^3/\text{rev})}$
<i>Fluid motor torque</i>	<i>lbs. in.</i>	$\frac{\text{pressure}(\text{psi}) \times \text{displacement} (\text{in}^3/\text{rev}) \times \text{mech. eff.}}{2\pi}$
<i>Fluid motor power</i>	<i>hp</i>	$\frac{\text{rpm} \times (\text{in}^3/\text{rev}) \times (\text{psi}) \times \text{overall eff.}}{395934}$
(metric)		
<i>Pump input torque</i>	<i>Nm</i>	$\frac{\text{pressure}(\text{bar}) \times \text{displacement} (\text{cm}^3/\text{rev})}{20\pi \times \text{mech. eff.}}$
<i>Pump input power</i>	<i>kW</i>	$\frac{\text{rpm} \times (\text{cm}^3/\text{rev}) \times (\text{bar})}{600000 \times \text{overall eff.}}$
<i>Pump output flow</i>	<i>Lpm</i>	$\frac{\text{rpm} \times (\text{cm}^3/\text{rev}) \times \text{volumetric eff.}}{1000}$
<i>Fluid motor speed</i>	<i>rpm(min⁻¹) (tr/mn)</i>	$\frac{1000 \times \text{flow rate} (\text{Lpm}) \times \text{volumetric eff.}}{\text{displacement} (\text{cm}^3/\text{rev})}$
<i>Fluid motor torque</i>	<i>Nm</i>	$\frac{\text{pressure}(\text{bar}) \times \text{displacement} (\text{cm}^3/\text{rev}) \times \text{mech. eff.}}{20\pi}$
<i>Fluid motor power</i>	<i>kW</i>	$\frac{\text{rpm} \times (\text{cm}^3/\text{rev}) \times (\text{bar}) \times \text{overall eff.}}{600000}$

"The product information specifications and descriptions contained in this catalog have been compiled for the use and convenience of our customers from information furnished by the manufacturer, and we cannot and do not accept any responsibility for the accuracy or correctness of any description, calculation, specification or information contained herein. No such description, calculated, specified or information regarding the products being sold has been made part of the basis of the bargain nor has same created or amounted to an express warranty that the products would conform thereto. **We are selling the goods and merchandise illustrated and described in this catalog on an as is basis and disclaim any implied warranty, including any warranty of merchantability or warranty of fitness for any particular purposes whatsoever, with respect to the goods and merchandise sold.** All manufacturer warranties shall be passed on to our customers, but we shall not be responsible for special, indirect, incidental or consequential damages resulting from the use of any of the products or information contained or described in the catalog."

Ordering Code **P16/260H - 02R1C - C10 - 00 - M2**

Pump service _____

Displacement, max* -----
16 - 16.0 in³/rev.
260 - 262,2 cm³/rev.

Model _____
Q-Quiet
H-High speed

Shaft -----
02-Keyed -SAE 44-1 (E) (P16)
 - ISO 3019/2 G50N (P260)
03-Splined -SAE 44-4 (E) (P16)
 - ISO 3019/2 K50N (P260)
05-Splined SAE 50-4 (F) Hi-Torque (P16)
06-Keyed - DIN 6885 60mm (P260)
07-Splined DIN 5480 60mm (P260)

Shaft rotation _____
 (viewed from shaft end)
R-CW (standard, high speed)
L-CCW (standard, high speed)

Fluid class -----
1-compatible with Buna N
4-compatible with EPR
5-compatible with Viton

Design letter _____

Primary controls -----
C-Pressure compensator
E-Electric stroker
H-Hydraulic stroker
J-Low torque limiter *2500-6000 lbs-in., 282.5-678 Nm
K-High torque limiter *over 6000 lbs-in., 678 Nm
L-Load sensing
R-Rotary servo
V- Low torque limiter with Load sensing
W- High torque limiter with Load sensing
X- 24 VDC PQ high response

* Minimum torque values to maintain 5000 psi, 345 bar at 1800 rpm. Consult DENISON Hydraulics for minimums at lesser pressures and speeds.

Omit-Standard model
M2- Special modification to standard units
NP- No paint

Modification
O No pump mounted
1- Auxiliary pump (only) with M- modification
 (user must advise attitude of rear pump/s mounting. For ordering two *standard* or three or more units refer to ordering code for multiple units)

Rear drive mounting
 (Appropriate coupling and seals are included)

O-None
M-Rear drive blanking plate
A-SAE 82-2 (A) flange, SAE 16-4 (A) shaft
G-SAE 82-2 (A) flange, SAE 22-4 (B) shaft
B-SAE 101-2/4 (B) flange, SAE 22-4 (B) shaft
Q-SAE 101-2/4 (B) flange, SAE 25-4 (BB) shaft
C-SAE 127-2/4 (C) flange, SAE 32-4 (C) shaft
N-SAE 127-2/4 (C) flange, SAE 38-4 (CC) shaft
D-SAE 152-4 (D) flange, SAE 44-4 (D&E) shaft
E-SAE 165-4 (E) flange, SAE 44-4 (D&E) shaft
Z-ISO 3019/2 (100 B4HW) flange, K25N shaft
Y-ISO 3019/2 (125 B4HW) flange, K32N shaft
X-ISO 3019/2 (160 B4HW) flange, K40N shaft
T-ISO 3019/2, (180 B4HW) flange, K40N shaft
U-ISO 3019/2, (180 B4HW) flange, K50N shaft
L-ISO 3019/2, (180 B4HW flange, DIN 40-18 shaft
S-ISO 3019/2, (180 B4HW) flange, DIN 50-24 shaft
W-ISO 3019/2, (200 B4HW) flange, K50N shaft
V-ISO 3019/2, (250 B4HW) flange, K50N shaft

Secondary controls

O-None
P-*Pressure compensator override
J-*Torque limiter override (low) 2500-6000 in-lbs., 282.5-678 Nm
K-*Torque limiter override (high) over 6000 in-lbs., 678 Nm
 (*E, H & R primary controls only)

Primary control options

1-Standard maximum volume screw, without indicator
2-Handwheel maximum volume control without indicator
 available on C, J, K, L, V & W primary controls only)
5-Maximum volume screw with cam position indicator
8-Handwheel max. vol. control with cam position indicator (available on C, J, K, L, V & W primary controls only)

Available control combinations

C10, C20, C50, C80
 E10, E50, E1P, E5P,
 E1J, E5J, E1K, E5K,
 H10, H50, H1P, H5P,
 H1J, H5J, H1K, H5K
 R10, R50, R1P, R5P,
 R1J, R5J, R1K, R5K
 J10, J20, J50, J80
 K10, K20, K50, K80
 L10, L20, L50, L80
 V10, V20, V50, V80
 W10, W20, W50, W80
 X10

International Distributors

In Europe:

Cyprus
Czech Republic
Eastern Europe
The Faroe Islands
Finland
Greece
Hungary
Iceland
Norway
Poland
Portugal
Roumania
Russia
Serbia Montenegro
Slovakia
Slovenia
Switzerland
Turkey

In Africa:

Algeria
Egypt
Ivory Coast
Morocco
Nigeria
South Africa
Togo
Tunisia

In Middle East:

Bahrain
Iran
Israel
Jordan
Lebanon
Pakistan
Qatar
Saudi Arabia
Syria
United Arab Emirates

In Far East:

Indonesia
Korea
Malaysia
New Zealand
Philippines
Thailand

Australia

DENISON HYDRAULICS Pty. Ltd.
41-43 St. Hillers Road
P.O. Box 192
Auburn, N.S.W. 2144
Australia
Tel. (612) 9646 5200
Fax (612) 9643 1305

Other sales offices:

Queensland
South Wantirna Victoria
Western Australia

Austria

DENISON HYDRAULIK GmbH
Zweigniederlassung Linz
Haidbachstraße 69
A-4061 Pasching
Austria
Tel. (43) 7229 4887
Fax (43) 7229 63092

Benelux

DENISON HYDRAULICS
BENELUX B. V.
Pascalstraat 100
3316 Dordrecht
Holland
Tel. (31) 786179 900
Fax (31) 786175 755

Canada

DENISON HYDRAULICS
CANADA Inc.
2320 Bristol Circle, Unit 1
Oakville, ON L6H 5S2
Canada
Tel. (905) 829 5800
Fax (905) 829 5805

Other sales offices:

Montreal, QC
Calgary, AB

Denmark

DENISON HYDRAULIK
DENMARK A/S
Industrikrogen 2
DK-2635 Ishøj
Denmark
Tel. (45) 4371 15 00
Fax (45) 4371 15 16

Finland

DENISON HYDRAULICS
P.O. Box 1096
Alhotie 24
FIN-04431 Järvenpää
Finland
Tel./Fax (358) 0 2710 588

France

DENISON HYDRAULICS
FRANCE SA
14, route du Bois Blanc
BP 539
18105 Vierzon
France
Tel. (33) 2 48 53 01 20
Fax (33) 2 48 75 02 91

Other sales offices:

Bordeaux
Lyon
Paris

Germany

DENISON HYDRAULIK GmbH
Herderstrasse 26
D-40721 Hilden
Germany
Tel. (49) 2103 940-6
Fax (49) 2103 940-880

Other sales offices:

Dresden
Hanover
Stuttgart

Great Britain

DENISON HYDRAULICS U.K.
Ltd.
Kenmore Road
Wakefield 41, Industrial Estate
Wakefield, WF20XE
West Yorkshire
England
Tel. (44) 19 24 826 021
Fax (44) 19 24 826 146

Other sales offices:

Burgess Hill

Hong Kong

DENISON HYDRAULICS Ltd.
Unit 2, 25/F Wharf Cable Tower
9 Hoi Shing Road
Tsuen Wan
N.T., Hong Kong
Tel. (852) 24988381
Fax (852) 24991522

Italy

DENISON HYDRAULICS S.r.l.
Viale Europa 68
20090 Cusago
Milano
Italy
Tel. (39) 2 90330 1
Fax (39) 2 90390 695

Japan

DENISON JAPAN Inc.
4-2-1 Tsujido-Shinmachi
Fujisawa 251,
Japan
Tel. (81) 466 35 3257
Fax (81) 466 35 2029

Other sales office:

Osaka

Mexico, Central America, South America and Caribbean Countries Contact

DENISON HYDRAULICS Inc.
6167 NW 181 Terrace Circle North
Miami, FL 33015
USA
Tel. (305) 362 2246
Fax (305) 362 6220

P.R. China

DENISON HYDRAULICS Ltd.
3F, No. 1, Mao Jia Zhai, Bai Lian Jing
Pudong New Area,
Shanghai 200126, China
Tel. (86) 21 5886 8991
Fax (86) 21 5886 1978

Singapore

DENISON HYDRAULICS S.E.A. Pte.
Ltd.
No. 11 Lorong Tukang Dua
Singapore 2261
Tel. (65) 2687840
Fax (65) 2687847

Spain

DENISON HYDRAULICS, S.A.
Gomis, 1
08023 Barcelona
Spain
Tel. (34) 3418 46 87
Fax (34) 3211 65 07

Other sales offices:

San Sebastian

Sweden

DENISON HYDRAULICS
SVENSKA AB
Sporregatan 13
213 77 - Malmö
Sweden
Tel. (46) 40 21 04 40
Fax (46) 40 21 47 22

Other sales offices:

Spånga

Taiwan

DENISON HYDRAULICS Ltd.
6F-10, No. 79, Sec. 2, Roosevelt road,
Taipei, Taiwan, R.O.C.
Tel. (886) 2 3645101 / 3645102
Fax (886) 2 3639025

USA

DENISON HYDRAULICS Inc.
14249 Industrial Parkway
Marysville, OH 43040
USA
Tel. 937 644 3915
Fax 937 642 3738
For nearest Distributor:
Call toll free 1 800 551 5956
E-Mail address:
denison@denisonhydraulics.com
WWW address:
http://www.denisonhydraulics.com

Other sales offices:

Fulton, CA
Mulberry, FL
Moline, IL
Rock Island, IL
Kentwood, MI
Portland, OR
Canton, MS
Arlington, TX
Houston, TX

Other European, Middle East and African Countries Contact

DENISON HYDRAULICS
FRANCE SA
14, route du Bois Blanc
BP 539
18105 Vierzon Cedex
France
Tel. (33) 2 48 53 01 44
Fax (33) 2 48 53 01 46

Your local DENISON representative

DENISON Hydraulics