

DENISON HYDRAULICS

axial piston variable displacement with auxiliary
package external replenishing pump Goldcup
series P11S & P14S C mod

service information

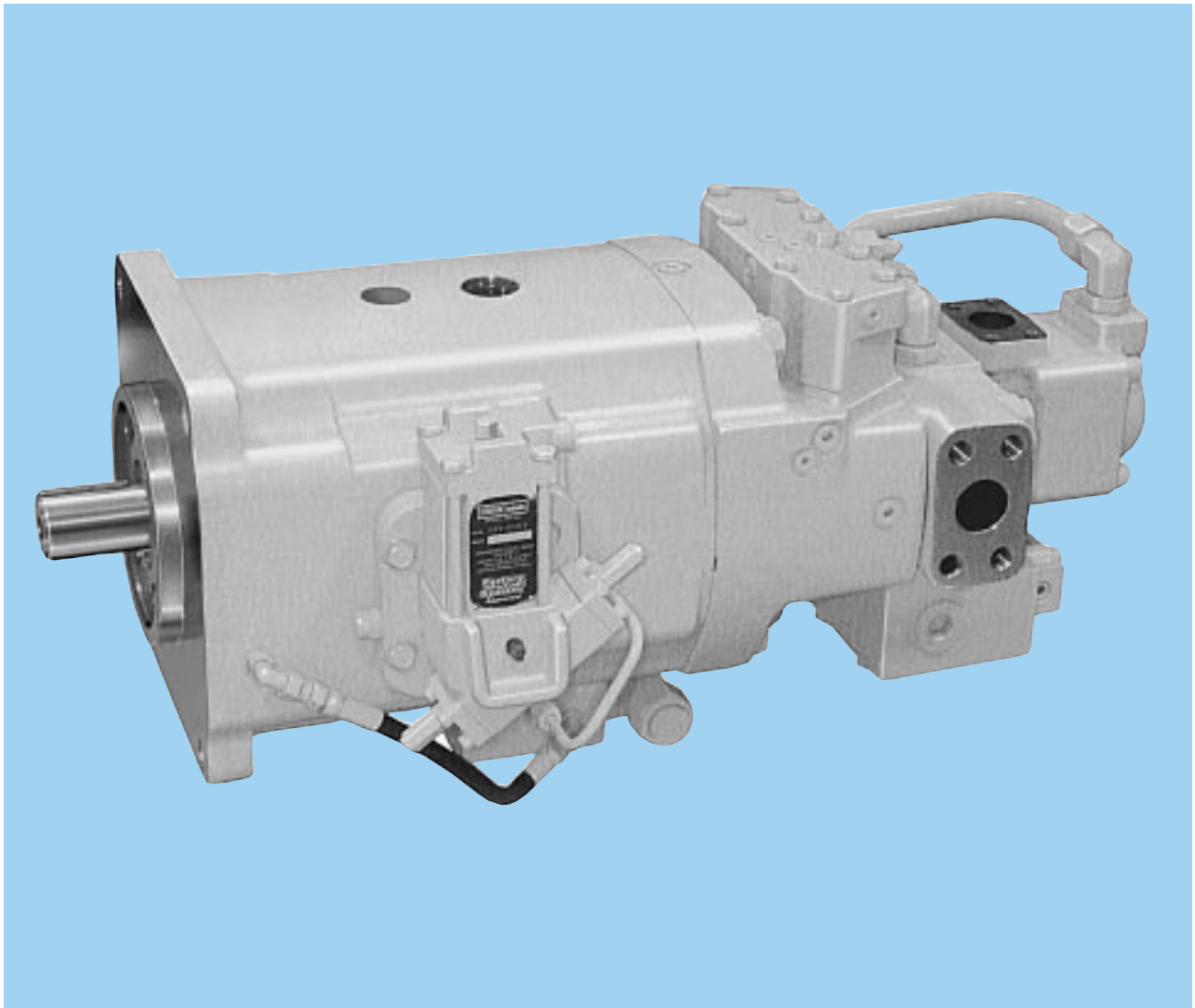

Publ. S1-AM023-C

Revised 6/04

DENISON Hydraulics

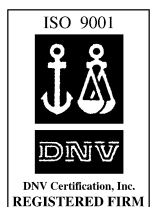

	PAGE
seal kits	-2
typical characteristics	-3
fluid connections	-3
installation	-4
maintenance	-5
comparison of solid contamination classification systems	-5
start up procedures-	-5
troubleshooting-	-6
disassembly-	-8
rework of wear part--	-9
assembly	-10
drive shaft & bearing	-10
barrel & auxiliary drive shaft	-10
rocker cam assembly	-12
piston/shoe/retainer assembly	-13
mtg. flg./cradle/barrel/aux. shaft assy	-13
housing assembly	-14
hsg./end cap/cam/barrel assembly	-14
port block assembly	-15
port block/housing assembly-	-15
gerotor & barrel holddown	-16
valve block assembly (after 7-93)	-18
valve block assembly for special mounting of servovalve (after 7-93)	-20
adapter assembly	-23
check valve assembly	-23
shuttle valve assembly	-23
pilot valve assembly	-24
shaft & seal installation	-26
A mod shaft seal replacement	-27
B mod shaft seal replacement	-27
counterbalance servo stem installation	-27
control cover installation	-28
instructions for replenishing isolation plug	-28
port locations	-28
gage pressure ranges	-29
conversion of A or B mod to C mod	-29
test procedure	-30
installation drawing-	-32
hydraulic circuit	-34
pump key sheet	-36
conversion formulas	-37

SEAL KITS

	part no.
pump seal kit complete, std. valve block, less control CW rotation	S23-15245
pump seal kit complete, std. valve block, less control CCW rotation	S23-15246
shaft seal - outer	620-82101
shaft seal - inner CW rotation	620-82104
shaft seal - inner CCW rotation	620-82105
std. valve block seal kit	S23-00135
hi IQ valve block seal kit	S23-02446
shuttle valve seal kit	S23-15089
1** thru 6**control	S23-02303
6A control	S23-02305
8** control	S23-15156
9**control	S23-15157-5
output indicator, 1** and 4A control	S23-02304
**4 torque limiter	S23-02302

Note: Throughout this bulletin, metric quantities are indicated in parenthesis, and decimal point is designated by a period

TYPICAL CHARACTERISTICS

Specification	Term	Goldcup 11	Goldcup 14
• displacement at max. angle	in ³ /rev.	11.00	14.00
	cm ³ /rev.	(180)	(229)
• pressure continuous	psi	5000	5000
	bar	(345)	(345)
• pressure intermittent	psi	6000	6000
	bar	(414)	(414)
• speed, max. continuous-full stroke	RPM	2400	2400
• speed, max. continuous-half stroke	RPM	2800	2800
• flow, ports A or B @ 1800 RPM (theoretical)	GPM	85.7	109.1
	l/min.	(324.4)	(412.9)
• flow, int. aux. pump @ 1800 RPM (theoretical)	GPM	16.7	16.7
	l/min.	(63.1)	(63.1)
• flow, ext. aux. pump @ 1800 RPM (theoretical)	GPM	9.8	9.8
	l/min.	(37.2)	(37.2)
• replenish pressure	psi	330-370	330-370
minus case pressure	bar	(22,76-25,52)	(22,76-25,52)
• servo pressure minus case	psi	490-790	490-790
pressure @ zero discharge pressure	bar	(33.79-54.48)	(33.79-54.48)
• max. continuous case pressure	psi	75	75
	bar	(5.2)	(5.2)
• max. intermittent case pressure	psi	125	125
	bar	(8.6)	(8.6)
• control on - stroke response time	sec.	1.5	1.5
• typ. compensator off - stroke time	sec.	.07	.07
• mounting-4 bolt flange	SAE	E	E
• shaft-spline or keyed	SAE	E	E
• weight w/spg. ctd. rotary servo	lbs.	485	485
	kg.	(220)	(220)

FLUID CONNECTIONS

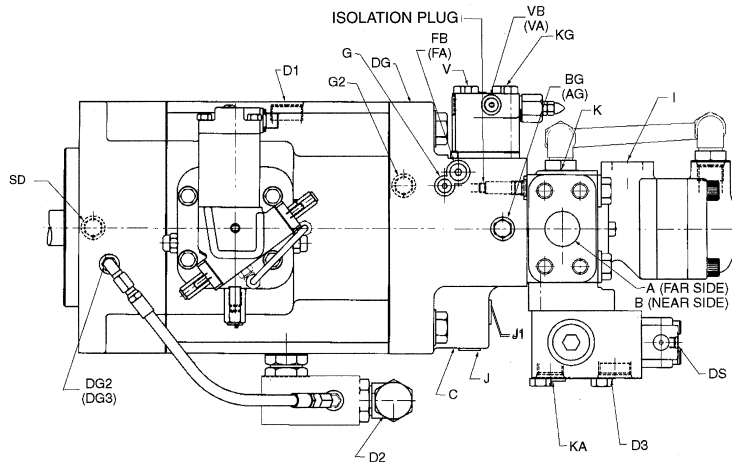

PORT LOCATIONS AND SIZES

• ports A & B (system) SAE code 62 split flange	in.	1-1/2
	mm	(38.1)
• port AG, BG (A&B system gage) straight thread O-ring seal	SAE	-6
• port C (aux. pump inlet) SAE code 61 split flange	in.	1-1/4
	mm	(31.8)
• port D1 (aux. case drain) straight thread O-ring seal	SAE	-16
• port D2 (case drain) 37° flared	SAE	-16
• port D3 (repl. relief drain) straight thread O-ring seal	SAE	-16
• port DG (case gage) straight thread O-ring seal	SAE	-6
• port DG2 (bearing flush) straight thread O-ring seal	SAE	-4
• port DG3 (air bleed) straight thread O-ring seal	SAE	-4
• port DS (shuttle repl. pilot drain) straight thread O-ring seal	SAE	-4
• port FA, FB (control pressures) straight thread O-ring seal	SAE	-6
• port G (servo pressure both sides) st. thd. O ring seal	SAE	-4
• port G2 (servo pressure A side) straight thread O-ring seal	SAE	-8
• port I (external aux. pump inlet) SAE code 61 split flange	in.	1-1/4
	mm	(38.1)
• port J (internal aux. pump outlet)	SAE	-8
• port J1 (internal aux. pump outlet)	SAE	-10
• port K (aux. repl. inlet) straight thread O-ring seal	SAE	-16
• port KG (repl. gage) straight thread O-ring seal	SAE	-6
• port SD (seal drain) straight thread O-ring seal	SAE	-4
• port V (common vent) straight thread O-ring seal	SAE	-4
• port VA, VB (A&B individual vents) straight thread O-ring seal	SAE	-4

INTRODUCTION

The **DENISON HYDRAULICS** Goldcup 11 and Goldcup 14 axial piston pumps feature advance design concepts which are time proven and provide for advance pumping and control concepts. The instructions contained in this manual cover complete disassembly and re-assembly of the unit. Before proceeding with the disassembly or re-assembly of any unit, this manual should be studied in order to become familiar with proper order and parts nomenclature.

DESCRIPTION

The use of a rocker cam to control the pump displacement provides a small package size, reduces wear, and speeds control response. The control vane actuator eliminates linkage and backlash inherent in typical stroking cylinder designs.

Standard controls for the Goldcup units are rotary servo and compensator over-ride. Additional optional controls are also available.

MOUNTING

This pump is designed to operate in any position. The mounting hub and four bolt mounting flange are in full conformance with SAE standard. The pump shaft must be in alignment with the shaft of the driven load and should be checked with a dial indicator. The mounting pad or adapter into which the fluid pump pilots must be concentric with the pump shaft to prevent bearing failure. This concentricity is particularly important if the shaft is rigidly connected to the driven load without a flexible coupling.

SHAFT INFORMATION

Splined: The shafts will accept a maximum misalignment of .006" TIR (0.15 mm). Angular misalignment at the male and female spline axes must be less than $\pm .002$ " per inch radius (0.002 mm per mm radius). The coupling interface must be lubricated. **DENISON HYDRAULICS** recommends lithium- molybdenum disulfide or similar grease. The female coupling should be hardened to 27-45 Rc and must conform to SAE-J498B (1971) class 1 flat root side fit.

Keyed: High strength heat treated keys must be used. Replacement keys must be hardened to 27-34 Rc. The key corners must be chamfered .030"- .040" (0.75-1 mm) at 45° to clear radii that exist in the keyway.

SIDE LOAD

Keyed shafts will accept a side load of 1000 lb. (454 kg) at the center of the key, with a B10 life of 10000 hours at 1800 RPM and 40 psi case pressure.

PIPING

CAUTION: Do not use galvanized pipe. Galvanized coating can flake off with continued use.

Connect inlet and outlet lines to the port block of the pump.

The maximum case pressure is 75 PSI (5.7 bar) continuous, 125 PSI (8.6 bar) intermittent. A 5 PSI (0.3 bar) case pressure check valve is included in the normal case drain port, D2, to be certain the case is filled with oil at all times.

The case leakage line must be of sufficient size to prevent back pressure in excess of 75 PSI (5.7 bar) and returned to the reservoir below the surface of the oil as far from the supply suction as possible. All fluid lines, whether pipe, tubing, or hose must be adequate size and strength to assure free flow through the pump. An undersize inlet line will prevent the pump from operating at full rated speed. An undersize outlet line will create back pressure and cause heat generation. Flexible hose lines are recommended. If rigid piping is used, the workmanship must be accurate to eliminate strain on the pump port block or to the fluid connections. Sharp bends in the lines must be eliminated wherever possible. All system piping must be cleaned with solvent or equivalent before installing pump. Make sure the entire hydraulic system is free of dirt, lint, scale, or other foreign material. Flushing with a large temporary high pressure loop filter is recommended.

SERVICE INFORMATION

These hydraulic products are designed to give long dependable service when properly applied and their systems properly maintained. These general instructions apply to typical systems. Specific instructions for particular equipment can be developed from them.

RECOMMENDED FLUIDS

The fluid recommended for use in these pumps and motors has a petroleum base and contains agents which provide oxidation inhibition and anti-rust, anti-foam and de-aerating properties as described in **DENISON HYDRAULICS** standard HF-1. Where anti-wear additive fluids are specified, see **DENISON HYDRAULICS** standard HF-0.

VISCOSITY

Max. at cold start - 7500 SUS (1600 cSt)
 (at low pressure, low flow, and if possible, low speed)
 Max. at full power - 750 SUS (160 cSt)
 Optimum for max. life - 140 SUS (30 cSt)
 Minimum at full power - 60 SUS (10 cSt)

VISCOSITY INDEX

90 V.I. minimum. Higher values extend the range of operating temperature but may reduce the service life of the fluid.

TEMPERATURE

Determined by the viscosity characteristics of the fluid used. Because high temperatures degrade seals, reduce the service life of the fluid and create hazards, fluid temperatures should not exceed 180° F (82° C) at the case drain.

ALTERNATE FLUIDS

Some applications require fire-resistant fluids. They will give good service if the system is originally designed for their use. Permissible fire resistant fluids include:

Type	DENISON HYDRAULICS Standard
Water-in-oil invert emulsions	HF-3
Water glycol solutions	HF-4
Phosphate esters	HF-5

Consult **DENISON HYDRAULICS** for design requirements and warranty limitations for service with this class of fluids.

See **DENISON HYDRAULICS** bulletin SPO-AM305 for more information.

MAINTENANCE

This pump is self-lubricating and preventative maintenance is limited to keeping system fluid clean by changing filters frequently. Keep all fittings and screws tight. Do not operate at pressures and speeds in excess of the recommended limit. If the pump does not operate properly, check the troubleshooting chart before attempting to overhaul the unit. Overhauling is relatively simple and may be accomplished by referring to the disassembly, rework limits of wear parts, and assembly procedures.

FLUID CLEANLINESS

Fluid must be cleaned before and continuously during operation, by filters that maintain a cleanliness level of NAS 1638 class 8 (class 9 for 15 micron and smaller). This approximately corresponds to ISO 17/14. This fluid level cleanliness can usually be accomplished by the effective use of 10 micron filters. Better cleanliness levels will significantly extend the life of the components., As contaminant generation may vary with each application, each must be analyzed to determine proper filtration to maintain the required cleanliness level.

COMPARISON OF SOLID CONTAMINATION CLASSIFICATION SYSTEM

NATIONAL AERONAUTICS STANDARD (NAS) 1638

		class													
		00	0	1	2	3	4	5	6	7	8	9	10	11	12
particle size range	5-15µm	125	250	500	1000	2000	4000	8000	16000	32000	64000	128000	256000	512000	1024000
	15-25µm	22	44	89	178	356	712	1425	2850	5700	11400	22800	45600	91200	182400
	25-50µm	4	8	16	32	63	126	253	506	1012	2025	4050	8100	16200	32400
	50-100µm	1	2	3	6	11	22	45	90	180	360	720	1440	2880	5760
	>100µm	0	0	1	1	2	4	8	16	32	64	128	256	512	1024
maximum particles	>5µm	152	304	609	1217	2432	4864	9731	19462	38924	77849	155698	311396	622792	1245584
	>15µm	27	54	109	217	432	864	1731	3462	6924	13849	27698	55396	110792	221584

ISO:DIS 4406; SAE J1165

		iso solid contaminant code														
		8/5	9/6	10/7	11/8	12/9	13/10	14/11	15/12	16/13	17/14	18/15	19/16	20/17	21/18	22/19
maximum	>5µm	250	500	1000	2000	4000	8000	16000	32000	64000	130000	250000	500000	1000000	2000000	4000000
particles	>15µm	32	64	130	250	500	1000	2000	4000	8000	16000	32000	64000	130000	250000	500000

NOTES: All measurements are for a 100 ml sample size.

START UP PROCEDURES FOR NEW INSTALLATION

- Read and understand the instruction manual. Identify components and their function.
- Visually inspect components and lines for possible damage.
- Check reservoir for cleanliness and drain and clean as required.
- Check fluid level and fill as required with filtered fluid at least as clean as that recommended. Fill pump case with clean oil prior to starting.
- Check alignment of drive.
- Check oil cooler and activate it, If included in circuit.
- Reduce pressure settings of relief valve. Make sure accurate pressure readings can be made at appropriate places.
- If solenoids are included in system, check for actuation.
- Start pump drive. Make sure pump and motor fill properly.

**START UP PROCEDURES FOR
NEW INSTALLATION**

(continued)

- Bleed system of air. Recheck fluid level.
- Cycle unloaded machine at low pressure and observe actuation (at low speed, if possible).
- Increase pressure settings gradually in steps. Check for leaks in all lines especially in pump and motor inlet lines.
- Make correct pressure adjustments.
- Gradually increase speed. Be alert for trouble as indicated by changes in sounds, system shocks and air in fluid.
- Equipment is operational.

TROUBLESHOOTING

Component problems and circuit problems are often interrelated. An improper circuit may operate with apparent success but will cause failure of a particular component within it. The component failure is the effect, not the cause of the problem

This general guide is offered to help in locating and eliminating the cause of problems by studying their effects.

effect of trouble	possible cause	fault which needs remedy
noisy pump	air in fluid	leak in suction line low fluid level turbulent fluid return lines above fluid level gas leak from accumulator excessive pressure drop in the inlet line from a pressurized reservoir suction line strainer acting as air trap
	cavitation in rotating group	fluid too cold fluid too viscous fluid too heavy shaft speed too high suction line too small suction strainer too small suction strainer too dirty operating altitude too high boost or replenishment pressure too low replenishment flow too small for dynamic conditions
	misaligned shaft	faulty installation distortion in mounting axial interference faulty coupling excessive overhung loads
	mechanical fault in pump	piston and shoe looseness or failure bearing failure incorrect port plate selection or index eroded or worn parts in the displacement control
erosion on barrel ports and port plate	air in fluid cavitation	see above see above
high wear in pump and motor	excessive loads	reduce pressure settings reduce speeds
	contaminant particles in fluid	improper filter maintenance filters too coarse introduction of dirt fluid to system reservoir openings improper reservoir breather improper line replacement
	improper fluid	fluid too thin or thick for operating temperature breakdown of fluid with time/temperature/shearing effects incorrect additives in new fluid destruction of additive effectiveness with chemical aging
	improper repair	incorrect parts incorrect procedures, dimensions, finishes
	unwanted water in fluid	condensation faulty breather/strainer heat exchanger leakage faulty clean-up practice water in makeup fluid

effect of trouble	possible cause	fault which needs remedy
pressure shocks	cogging load	mechanical considerations
	worn relief valve	needed repairs
	worn compensator	needed repairs
	slow response in check valves	replace or relocate
	servo pressure too low to maintain firm control	increase pressure and check pressure drop through servo filter
	excessive decompression energy rates	improve decompression control
	excessive line capacitance (line volume, line stretch, accumulator effects)	reduce line size or lengths eliminate hose
barrel blow-off	re-check pump hold-down, rotating group, drain pressure	
heating of fluid	excessive pump or motor leakage	recheck case drain flow and repair as required fluid too thin improper assembly, port timing
	relief valve	set too low (compared to load or to compensator) instability caused by back pressure, worn parts
	compensator	set too high (compared to relief) worn parts
	pump too large for fluid needs	select smaller pump displacement
	heat exchanger	water turned off or too little flow water too hot fan clogged or restricted efficiency reduced by mud or scale deposits intermittent hydraulic fluid flow
	reservoir	too little fluid entrained air in fluid improper baffles insulating air blanket that prevents heat rejection heat pickup from adjacent equipment

FILLING CASE

It is essential to make certain that the case (pump housing) is as full of fluid as possible and remains full during operation and at rest. Always fill to the highest available point. Remove a plug or screw and allow the oil to escape through this point.

Recommended fill ports:

Mounting orientation vertical, shaft up. D1 (drain) port in housing. Vent DG3 port in mounting flange (new units) or one of the upper screws which attach the control. See installation drawing.

Mounting orientation vertical, shaft down, horizontal, drain ports to the side: D1 or D2 (drain) port in housing. Vent DG (case gage) port in port block. Vent DG3 port in mounting flange (if on correct side) or screw from the upper control cover.

SPECIAL INSTRUCTIONS FOR MOUNTING AUXILIARY PUMP

CAUTION: The shaft and seal area of a rear mounted pump will be exposed to the primary pump's case pressure. This can cause damage to the rear mounted pump's shaft seal. When using an external pump other than the Denison vane pump normally supplied with the rear drive "S" version pump, note the following:

For a rear mounted pump without external drain, modification of the pump's shaft seal will be required if case pressure exceeds that which the rear seal can withstand. If the rear mounted pump contains a case drain, the primary and the rear mounted pump case drains may be connected to a common line to equalize the pressures on the shaft seal.

INTRODUCTION

The instructions contained in this section cover a complete teardown of the subject pump. Disassemble only as far as necessary to replace or repair any worn parts.

DISASSEMBLY

Position pump unit so that valve block assembly is on top. A bench or similar suitable surface capable of supporting unit should be used. Disassembly area should be clean.

VALVE BLOCK

See figure 16. Remove the eight hex head cap screws (18) and lift the entire block assembly from the port block.

See figure 10. Remove the four screws (43) and remove the retainer plate (42). Remove the seats (27 & 28), poppets (30 & 31), and springs (32, 33 & 35).

Remove the plugs (20, 23 & 25) and pin (21). Refer to servo strainer assembly (14). Remove the SHCS retaining the strainer, remove the strainer and strainer support

Remove housing (8) and O-ring (9). Remove items (6), (7), and (45) as a unit. Insert a small brass rod through the hole in the housing and tap out piston (10) and O-ring (11).

Remove spring (12) and cone (13). Remove seat (5) and O-ring (4). **NOTE:** Seat is made for hex wrenching. Use 1/2" 6 point socket with 1/4" drive.

Remove replenishing relief valve (36). (Replenishing relief valve is located behind plug (25). Inspect orifices (3) to insure they are open. Do not remove unless damage or clogging is apparent.

Do not remove spring pins (26) and (46) unless replacements are needed.

CONTROLS

See figure 16. Remove the four screws (15) from the side cover (17) and remove the input shear seal control assembly.

Remove the four screws (15) from the side cover (16) and remove the counter balance shear seal control assembly.

Remove the screws (13) and (10) and remove the balance stem (9) and balance plate (11).

EXTERNAL PUMP, SHUTTLE VALVE AND REAR ADAPTER

Remove two screws (21) and remove external pump (22).

Remove four screws (25) and remove shuttle valve (26).

Remove four screws (9, fig. 12) and remove adapter (24).

BARREL HOLDDOWN AND GEROTOR ASSEMBLY

See figure 9. Remove locking ring (18), pin (17), hold-down nut (16), insert (19), thrust washers (13), bearing (14) and seal ring (15).

Remove pressure plate (12), "O" rings (10) and (11), and side plate assembly (9).

Remove servo gerotor assembly (7), dowel pin (8), key (6), and center port plate (4).

Remove replenishing gerotor (3), key (2) and side plate (1).

PORT BLOCK

See figure 8. Remove four screws (1) that secure the port block (2) to the housing (6). Use caution when removing screws on valve block side to prevent marring valve block face.

Remove port block (2) and gasket (5). Remove port plate (4) and port plate pins (3). Note: port plate will in some instances adhere to port block upon disassembly.

See figure 7. Remove the check valve assemblies (7) from the port block.

Remove the needle bearing (2) from the port block.

Remove plugs (8,10 and 12).

Remove two screws (4), lockwashers (5), check rings (3) and clamps (6).

BARREL AND AUXILIARY SHAFT

Remove face plate and pins (2 and 1, fig. 6) from face of barrel assembly.

Remove the barrel assembly (1, fig. 4) by grasping the auxiliary shaft and lifting the complete assembly out of the housing.

DRIVE SHAFT

See figure 16. Remove bearing pre-load spring (27). Remove the four screws (8) and gaskets (7). Remove seal retainer (6), and shaft assembly (1) from pump. Note: Version "A" pumps contain a mechanical shaft seal. Replacement kits S23-15218 (CW rotation) or S23-15349 (CCW rotation) contain all the parts to modify earlier models to the version C design.

HOUSING

After shaft assembly has been removed, position the unit on end with the mounting flange turned down.

Push the ends of the small tube lines away from the housing.

Lift the housing from the mounting flange. Remove the gasket and locating sleeves from the mounting flange.

Do not remove the spring pins and the bearing from the housing unless the bearing is damaged and must be replaced.

ROCKER CAM AND CONTROL STROKING ASSEMBLY

See figure 4. Remove the complete assembly from the mounting cap and position on a clean flat surface with the two tubes (2) in a horizontal position and located at the top. Mark the cam (24) and cradle (20) as indicated in figure 3. These marks will assure re-assembly in the same position.

Carefully remove the small tube lines (5) and (6) from the cradle. Caution: do not bend these lines

See figure 3. Position the assembly in an upright position on the flat surface of the cradle (19). Remove the retaining ring (1) thrust washer (2) and bearing (3). Remove the piston and shoe assembly (4) and the creep plate (5) from the cam (22). Carefully remove the two set screws (12) and two screws (9) that secure the servo plate (10) to the servo stem (6). Remove the servo input parts (6, 7 and 8).

Remove the four screws (11) and four screws (13) from the control covers (14R) and (14L). Remove the four dowel pins (15) and remove the two chambers (16). Remove the two special seals (18) and the four steel balls (17). Remove the two vane seal cartridge assemblies (25) and the four holddown vanes (24) and springs (23) from the rocker cam (22).

Remove the rocker cam (22) from the cradle (19). Caution: Do not remove the plugs from the rocker cam.

REWORK LIMITS OF WEAR PARTS

11 and 14 in3	max. rework from original	min. dimension after rework
port plate face	.010" (0.254 mm)	.705" (17.9 mm)
shoe retainer face	.005" (0.127 mm)	.432" (10.97 mm)
piston shoe face (pocket)	.010" (0.254 mm)	.010" (0.254 mm)
creep plate face	.010" (0.254 mm)	.240" (6.1 mm)
face plate	none	replace

IMPORTANT:

The port plate finish must be 25 microinches (635 μmm) both faces, flat within .00006" (0.0015 mm) and parallel within .001" (0.0254 mm) T.I.R.

The creep plate wear face finish must be 10 microinches (254 μmm), flat within .0002" (0.0508 mm) and parallel to the backside within .0005" (0.0127 mm) T.I.R.

The shoe retainer wear face finish must be 32 microinches (813 μmm) and flat within .0015" (0.0381 mm). (Must not be convex).

The piston shoes wear face finish must be 5 microinches (127 μmm) and must be lapped in a set with the retainer plate, all shoe sole thicknesses to be within .001" (0.0254 mm) after lapping. The maximum permissible shoe and piston axial looseness is .010" (0.254 mm)

The special retaining ring service kit (S23-12547) may be required to control shoe holddown clearance

CLEANING AND INSPECTION

All parts must be inspected and be free of material defects, dirt, scratches or any foreign material.

All parts must be cleaned with a suitable cleaning solvent and all holes and passages blown out with dry, clean, compressed air. After cleaning and inspection, all parts must be covered with a light film of oil and protected from dirt and moisture. Excessive handling of internal parts should be avoided prior to assembly.

During assembly, lapped and ground surfaces must be lubricated with clean oil and protected from nicks or surface damage.

DRIVE SHAFT AND BEARING

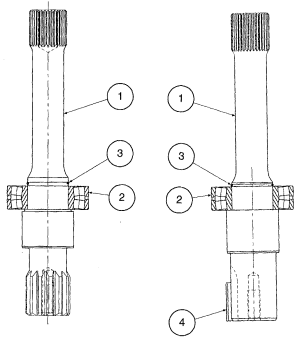

FIGURE 1

See Figure 1. Press the bearing (2) over the end of the shaft and seat against the shoulder. Support only the inner race of the bearing and press on the coupling end of the shaft. Caution: Do not use excessive force.

Install retaining ring (3) in the retaining ring groove. Be sure that ring is fully seated.

PARTS LIST FOR FIGURE 1
S23-15212 DESIGN C DRIVE SHAFT ASSEMBLY (SPLINED)
S23-15213 DESIGN C DRIVE SHAFT ASSEMBLY (KEYED)

item	description	part no.	quantity	
			#3	#2
1	#3 (design C splined shaft)	033-91714	1	-
	#2 (design C keyed shaft)	033-91710	-	1
2	shaft bearing	230-82214	1	1
3	retaining ring	033-91486	2	2
4	square key 5/16 x 1-1/4	033-71514	-	1

BARREL AND AUXILIARY DRIVE SHAFT

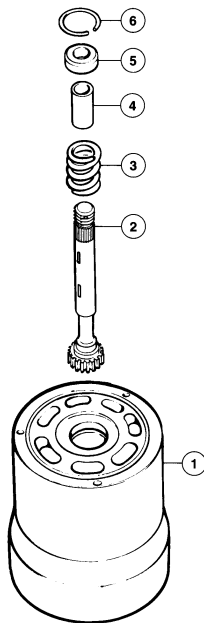

FIGURE 2
barrel and auxiliary drive shaft

See figure 2. Position the barrel (1) with the bores facing down on a clean surface.

Install holddown spring (3) into barrel counterbore.

Install spring retainer (5) into counterbore and seat against spring.

Install retaining ring (6) into barrel counterbore groove. Make sure retaining ring is fully engaged in groove.

Position barrel stop (4) over auxiliary drive shaft (2). Turn barrel on side and install auxiliary drive shaft and barrel stop through barrel spline and holddown spring.

PARTS LIST FOR FIGURE 2

item	description	part no.	quantity	
			P11	P14
1	barrel & sleeve ass'y (P11)	S13-45381	1	-
	barrel & sleeve ass'y.(P14)	S13-43965	-	1
2	auxiliary drive shaft	033-91053	1	1
3	barrel holddown spring	033-71562	1	1
4	stop	033-71561	1	1
5	spring retainer	033-71560	1	1
6	retaining ring	033-71564	1	1

PARTS LIST FOR FIGURE 3

rocker cam, pistons and retainer

item	description	part no.	qty.
1	retaining ring (yellow) .107"-.109" (2.72-2.77mm)	033-71556	1
	retaining ring (green) .105"-.107" (2.67-2.72 mm)	033-71557	
	retaining ring (red) .103"-.105" (2.62-2.67 mm)	033-71558	
	retaining ring (blue) .101"-.103" (2.56-02.62 mm)	033-71559	
	retaining ring (white) .098"-.100" (2.49-2.54 mm)	033-91231	
	retaining ring service kit	S23-12547	
2	thrust washer	033-91706	1
4	piston & shoe assembly w/retainer P11	S13-45544	1
	piston & shoe assembly w/retainer P14	S13-43970	
5	creep plate	033-71569	1
6	servo stem	033-71596	1
7	orifice screw	033-20641	2
8	soc. hd. cap screw	359-09240	2
9	button hd. screw	353-25073	2
10	servo plate	033-53874	1
11	hex. hd. screw 1/2-13 x 3"	306-40189	4
12	soc. setscrew	312-09032	2
13	hex. hd. screw 3/8-16 x 2-3/4"	306-40140	4
14R	right side chamber cover CW rot.	033-71598	1
	right side chamber cover CCW rot.	033-71595	
14L	left side chamber cover CW rot.	033-71597	1
	left side chamber cover CCW rot.	033-71593	
15	dowel pin	324-22428	4
16	chamber	033-71615	2
17	steel ball 3/16" H & G.	201-06001	4
18	seal	606-25040	2
19	rocker cradle, "C" design	033-91712	1
20	O-ring 90 S-1 ARP 905	691-00905	2
21	hex socket plug SAE-5	488-35020	2
22	rocker cam	S23-12107	1
23	vane spring	033-72233	12
24	hold down vane	033-72234	4
25	vane seal cartridge	see below	2
25a	seal backup plate	033-71608	4
25b	vane seal	033-71611	2
25c	O-ring 90 S-1 ARP 125	691-00125	2
25d	spacer	033-71607	2
25e	check valve	033-70803	2
26	override tube	033-71609	2

FIGURE 3
rocker cam assembly

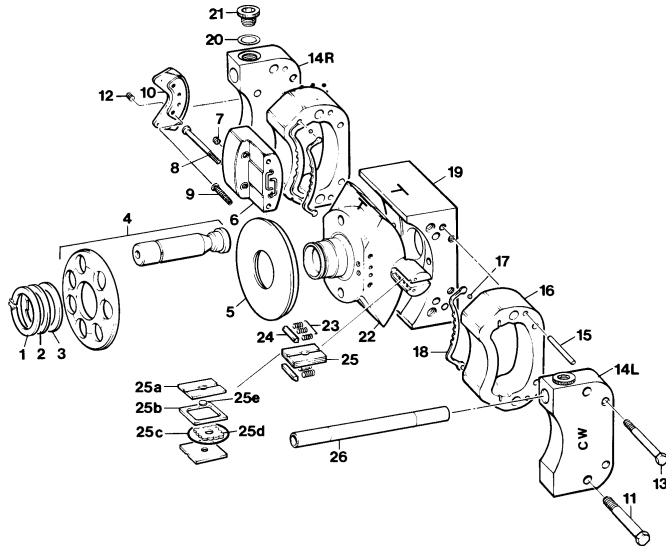

ROCKER CAM ASSEMBLY

See figure 3. Position the cradle (19) on a clean flat surface with the large flat area down.

Position the rocker cam (22) on the cradle (19). Note marks made earlier to indicate top of rocker cam & cradle.

Place O-ring (25c) around spacer (25d) and insert in the vane seal (25b).

Insert check valve (25e) inside of spacer (25d) and assemble between the two backup plates (25a) with the notched V's exposed.

Install assembled cartridge in slot in cam as indicated in figure 3. Repeat on opposite side of cam.

Insert the four holddown vanes (24) and springs (23) in the slots on each side of the control vanes (25). **Note:** Install holddown vanes with beveled edge sloping away from the vane seal cartridges.

Position both control chambers (16) on a clean flat surface with seal grooves turned up. Drop the four steel balls (17) in the four counterbored holes at each end of the seal grooves.

Lubricate seals (18) and insert in seal grooves in control chamber (16). Note: The tapered side of the seals must be pushed into the grooves and the ends must cover the steel balls.

Install the control chamber (16) with seal (18) and steel balls (17) assembled over the control vane (25). The seal must be against the cam. Rotate the chamber until it passes over the control vane assembly, then rotate in the opposite direction until the dowel pins (15) can be pushed through the chamber (16) and into the cradle (19). Install chamber in the same manner on the other side of the cam.

Two sets of chamber covers are available. The set marked CW must be installed in the right hand rotation pump, and the set marked CCW must be used in the left hand rotation pump. (Rotation is determined facing the pump shaft end). The covers must be installed with the tubing holes and the tapped holes at the top of the unit. Install chamber covers (14R) and (14L) on the control chambers (16) over the dowel pins (15). Referring to the "T" marked on the rocker cam (22) and cradle (19), the tapped holes must be at the top.

Install two 1/2-13 screws, (11) in each side and torque to 75 ft. lb. (101.7 Nm).

Install two 3/8-16 hex hd. screws (13) in each side and torque to 30 ft. lb. (40.7 Nm).

Install O-ring (20) and plug (21) in each cover.

Install tubes (26) in reamed holes in each cover. These tubes must be a tight fit. If tubes are loose, the ends can be expanded with a tapered punch. Tap the tubes in

place with a plastic mallet.

Install two orifice screws (7) in the servo stem (6). Position the stem on the rocker cam input side at 9 o'clock position on "B" suffix, or 3 o'clock for "A" suffix models.

Install servo stem on rocker cam using screws (8). Torque to 70 in.-lbs. (7.91 Nm).

Install two #10-24 button hd. screws (9) in the servo plate (10). Install servo plate with the button hd. screws into the servo stem. Torque the screws to 30 in.-lb. (3.39 Nm).

Install two soc. setscrews (12) in the servo plate (10) and torque to 5 ft.-lb. (6.8 Nm). Caution: the screws must not protrude above the servo plate.

Install creep plate (5) over center post on rocker cam (22) with small O.D. of plate turned toward cam.

PISTON/SHOE/RETAINER ASSEMBLY

Position the piston/shoe/retainer assembly (4) over the center post and against the creep plate. Install bearing (3) and thrust washer (2) over center post of cam and against the creep plate.

Five different retaining rings (1) are available for the holddown assembly. Each ring is marked: white dot .099" (2.51 mm) thick, blue dot .102" (2.59 mm) thick, red dot .104" (2.64 mm) thick, green dot .106" (2.69 mm) thick, and yellow dot .108" (2.74 mm) thick. Install the thickest ring (1) with the dot up, that will fit in the groove on the center post and allows a maximum clearance of .002"-.004" (0.051-0.102 mm) between the shoe and creep plate while grasping one piston and lifting tightly against the shoe retainer.

The piston/shoe/retainer assembly (4) must be free to rotate easily by hand. The assembly must be rotated through 360° to confirm there is no binding and that each shoe is always free in the retainer plate. Oil the assembly thoroughly.

MOUNTING FLANGE, CAM & CRADLE, BARREL & AUX. SHAFT ASSEMBLY

See figure 4: Position the cradle and cam assembly with the piston and shoe assembly attached with "T" marked on the cradle turned up.

Install straight thread connectors (3) and O-rings (4) into threaded holes in cradle. Install right and left hand pressure feed tubes (5 & 6) to connectors (3). Tighten connectors until snug.

Position the mounting flange (9) with the large open end up, and the seal drain port at the six o'clock position. Install two dowel pins (8) in the cradle mounting surface of the flange and four locating sleeves (10) in the outer edge of the flange.

Position the rocker cam and cradle assembly over the mounting flange, with the override tubes at the 3 o'clock position. Install rocker cam and cradle assembly over the two dowel pins (8) in the mounting flange. Be certain that cradle is seated over the pins and against the flange.

Position the mounting flange, with the rocker cam assembly installed, on the top or bottom side and install two 3/8-16 screws through the seal retainer area and into the cradle. These screws are required to hold the rocker cam assembly in place and will be removed later.

Return the assembly to an upright position with the mounting flange down. Tilt the rocker cam to either extreme position in the cradle.

Position the barrel assembly with auxiliary shaft (1) directly over the pistons. Start with the uppermost piston and guide them one at a time into the barrel. Return the rocker cam to a level position in the cradle.

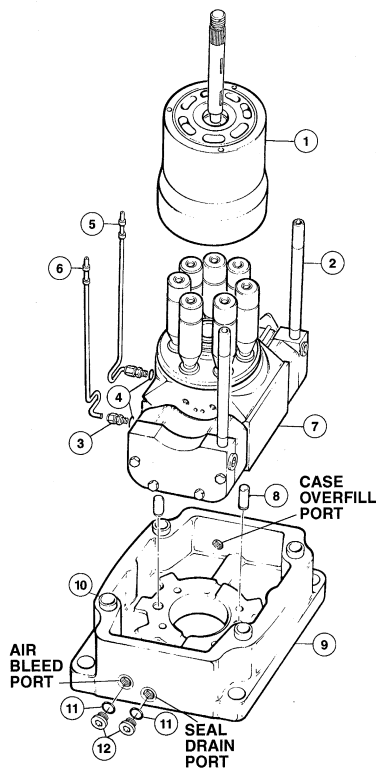

FIGURE 4
mounting flange, cam & cradle, barrel & aux. shaft assembly

PARTS LIST FOR FIGURE 4

item	description	part no.	qty.
1	barrel and auxiliary shaft assy.	see fig. 2	1
2	override pressure tube	033-71609	2
3	connector	492-15265	2
4	O-ring, 90 S-1 ARP 902	691-00902	2
5	tubing assembly (right side)	S13-43967	1
6	tubing assembly (left side)	S13-43966	1
7	rocker cam and stroking assembly	see fig. 3	1
8	dowel pin	324-23216	2
9	mounting flange, design C	033-91711	1
10	locating sleeve	033-72664	4
11	O-ring 90 S-1 ARP 904	691-00904	2
12	plug	488-35061	2

HOUSING ASSEMBLY

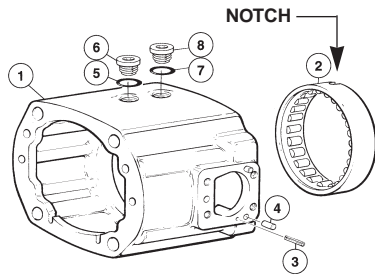

FIGURE 5
housing assembly

PARTS LIST FOR FIGURE 5

See figure 5: Wash and dry all parts. During assembly, lapped and ground surfaces should be kept lubricated with clean oil and protected from nicks or surface damage. Position housing (1) on a clean flat surface with the large open end up.

Clean housing (1) and barrel bearing (2). Apply loctite primer grade "T" and loctite retaining compound #609 to bearing O.D. and bearing bore of housing. Rest housing on mounting flange end.

Position notch in bearing (2) in alignment with retainer hole in the housing bore. With smooth and steady force, press the bearing into the housing bore until seated. **DO NOT HAMMER OR BEAT INTO PLACE.** Install bearing retainer (8) with O-ring (7). Torque to 50 lb. ft. (68 Nm). Place O-ring (5) on plug (6) and install adjacent to bearing retainer (8).

Turn housing (1) on side and install spring pin (3) in the 1/4" through hole in the control cover pad. The pin must be 3/8" (9.5 mm) below the pad surface. **THE PIN MUST NOT INTERFERE WITH THE INTERNAL BEARING CAGE.** Install two dowel pins (4) in the blind holes in the same pad. Repeat previous step on the opposite side of the housing.

PARTS LIST FOR FIGURE 5

S13-43962 housing assembly

item	description	part no.	qty.
1	housing	033-91191	1
2	bearing	033-91190	1
3	spring pin	325-16320	2
4	dowel pin	324-21608	4
5	O-ring 90 S-1 ARP 916	691-00916	1
6	hollow hex plug SAE-16	488-35024	1
7	O-ring 90 S-1 ARP 908	691-00908	1
8	bearing retainer	033-91106	1

**HOUSING/END CAP/CAM/
BARREL ASSEMBLY**

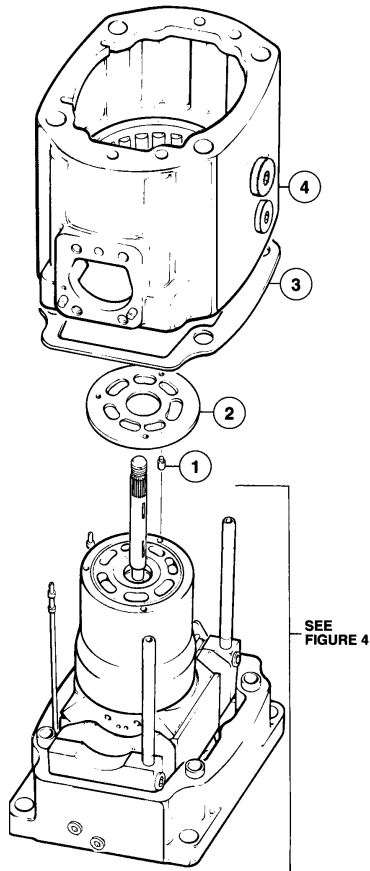

FIGURE 6

See figure 6: Install the three face plate pins (1) in the holes provided in the barrel face.

Apply heavy grease to the face of the barrel and install the face plate (2) over the pins (1) in the barrel.

Install gasket (3) over the four locating sleeves (item 10 on figure 4) in the mounting flange.

CAUTION: Make certain the face plate is properly seated on the barrel and pins with the steel side towards the barrel face. The face plates have only one side bronzed and this must be towards the port plate. If necessary, remove coating from edge of face plate to determine bronze side.

Position the housing assembly (4) over the barrel and auxiliary shaft assembly and carefully guide the override tubes and pressure feed tubes (items 2, 5, and 6 on figure 4) through the housing assembly (4).

PARTS LIST FOR FIGURE 6

item	description	part no.	qty.
1	face plate pins	033-49825	3
*2	barrel face plate P11 only	033-71921	1
	barrel face plate P14 only	033-71575	
3	housing gasket	033-91076	1
4	housing assembly (figure 5)	S13-43962	1
5	mtg. flange, cam, barrel assembly	see fig. 4	1

*Note: item 2 arcuate port width: P11 = 15/32" (11.9 mm) P14 = 5/8" (15.9 mm)

PORT BLOCK ASSEMBLY

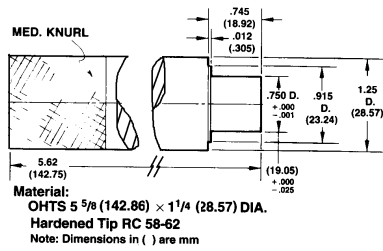

T-1

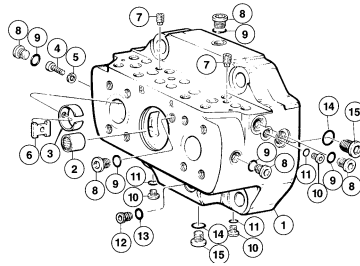

FIGURE 7
port block assembly

See **Figure 7**: Position the port block (1) on a clean flat surface with the two open ports up. **THE OPPOSITE FACE MUST NOT BE SCRATCHED OR DAMAGED.** Position needle bearing (2) on tool (figure T-1) with the marked end of the bearing against the shoulder on the tool and press the bearing (2) into the port block. The bearing must be .010" - .025" (0.254 - 0.635 mm) below the surface.

Slip check rings (3) into the two 1.50" ports and align holes in the ring with the side holes in the port wall. Place lock washers (5) on special screws (4). Insert screws (4) through port wall and drilled holes in checks (3) and thread into clamps (6). Torque to 10 ft. lb. (13.6 Nm). Thread two check valve assemblies (7) into valve face of port block.

Place O-rings (9, 11, 13 & 14) on hollow hex plugs (8, 10, 12 & 15) and thread into tapped holes in port block.

PARTS LIST FOR FIGURE 7
S13-44138 port block assembly

item	description	part no.	qty.
1	port block	033-57912	1
2	needle bearing	230-82146	1
3	check ring	033-70502	2
4	special screw	033-70908	2
5	lock washer #10	348-10016	2
6	clamp	033-70489	2
7	check valve assembly	S13-40266	2
8	hollow hex plug, SAE-6	488-35041	6
9	O-ring 70 S-1 ARP 906	691-00906	6
10	hollow hex plug, SAE-4	488-35001	4
11	O-ring 90 S-1 ARP 904	691-00904	4
12	hollow hex plug, SAE-10	488-35055	1
13	O-ring 90 S-1 ARP 910	691-00910	1
14	O-ring 90 S-1 ARP 908	691-00908	2
15	hollow hex plug, SAE-8	488-35018	2

FIGURE 8
port block/housing assembly

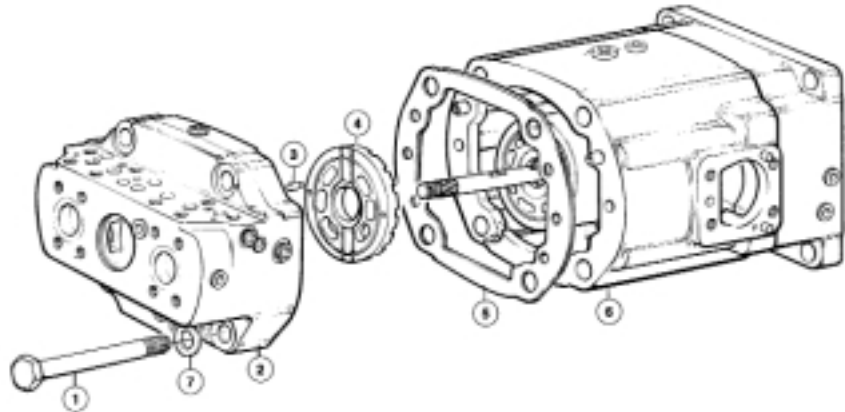

PORT BLOCK/HOUSING ASSEMBLY

See **figure 8**: Position the pump with the bearing retainer in the housing assembly at 12 o'clock position.

Install gasket (5) on the housing assembly (6).

Install the two special pins (3) in the face of the port block assembly. Apply petroleum jelly or heavy grease to the plate (4) and position port plate over the pins (3) on the port block. Port plate must be fully seated and indexed towards direction of rotation.

Slide the port block assembly and port plate over the end of the auxiliary shaft. Be certain that tubes 2, 5 and 6 shown on figure 4 are engaged and that the port plate (4) is still on the pins (3).

When the pump is properly assembled, the valve mounting surface will be at the top of the unit.

Install the four bolts (1) with washers (7), and torque bolts evenly in 50 ft.lb (68 Nm) increments to 350 ft. lb. (475 Nm) total.

PARTS LIST FOR FIGURE 8

port block/housing assembly

item	description	part no.	qty.
1	hex head cap screw	306-40172	4
2	port block assembly (figure 7)	S13-44138	1
3	port plate pins	324-21610	2
4	RH port plate 11 in3	033-71915	1
	LH port plate 11 in3	033-71914	
	RH port plate 14 in3	033-71617	
	LH port plate 14 in3	033-71600	
5	port block gasket	033-91079	1
6	housing/flange assembly	figure 6	1
7	washer	350-10109	4

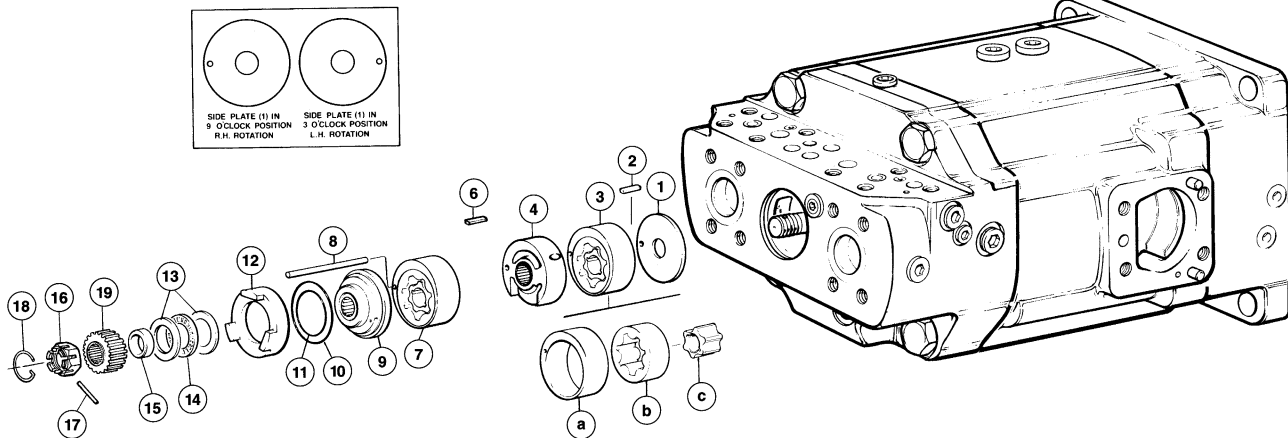

FIGURE 9

gerotor and barrel holddown

**GEROTOR AND BARREL
HOLDDOWN ASSEMBLY**

See figure 9: Position the unit with the shaft in a horizontal position and the valve block mounting surface turned up. Rotate the shaft until the small keyway in the auxiliary shaft is at 12 o'clock position.

If pump is being assembled for right hand rotation install dowel pin (8) in hole in port block at the 9 o'clock position when viewing from port block end of unit, if left hand pump, install at 3 o'clock position.

Install side plate (1), steel side first, over dowel pin. Insert key (2) in rear keyway on auxiliary shaft. Install the inner gear of the gerotor assembly (3c) on the shaft and over the key (2). Install the eccentric ring (3a) on the dowel pin (4). Install the large outer gear of the gerotor assembly (3b) inside the eccentric ring (3a) and over the inner gear.

Install center port plate (4) over the auxiliary shaft, engaging the dowel pin (8). The suction area of the port plate must be located at the bottom of the unit.

Install key (6) in the remaining auxiliary shaft keyway. Install the inner gear, eccentric ring and large outer gear of the gerotor assembly (7) as before.

Place O-rings (10) and (11) on side plate assembly (9). Lubricate the O-rings and slip the pressure plate (12) over the O-rings on the side plate assembly. Slip the two plates over the auxiliary shaft and position the gerotor side plate over the dowel pin

Note: When changing pump rotation consult parts list for proper side plate assembly (9).

(8).

Place seal ring (15) on auxiliary shaft. Position bearing (14) between the two thrust washers (13) and install around the seal ring (15). Install insert (19) over splline on shaft. Thread holddown nut (16) on the shaft and tighten no more than 10 ft. lb. (13.6 Nm) max. Back off the nut (16) until second slot is aligned with pin hole in the shaft. Insert pin (17) through nut and shaft and secure with ring (18).

Check the main shaft for smooth rotation. If not smooth, check the gerotor parts for position and holddown nut for proper adjustment.

ASSEMBLY PROCEDURES

PARTS LIST FOR FIGURE 9

gerotor and barrel holddown

item	description	part no.	qty.
1	side plate	033-71619	1
2	square key 1/8 x 9/16	211-22034	1
3	gerotor and eccentric ring assy, replenishing.	S13-43334	1
4	center port plate	S13-43963	1
6	square key 1/8 x 9/16	211-22034	1
7	gerotor and eccentric ring assy, servo.	S13-43334	1
8	dowel pin	033-71620	1
*9	side plate & bearing assembly	see below	1
10	O-ring 70 S-1 ARP 144	671-00144	1
11	O-ring 70 S-1 ARP 129	671-00129	1
12	pressure plate	033-70531	1
13	thrust washer	350-10081	2
14	bearing	230-82164	1
15	seal ring	033-72101	1
16	holddown nut	033-91052	1
17	pin	033-53921	1
18	retaining ring	033-53923	1
19	insert	033-91051	1

*for RH pumps use

S13-46762

*for LH pumps use

S13-46763

PARTS LIST FOR FIGURE 10

*valve block assembly
(after 7-93)*

item	description	part no.	qty.
1	valve block	033-91221	1
2	check valve assembly	S13-40266	2
3	orifice plug .047" (1.2 mm)	033-91249	4
4	O-ring 90 S-1 ARP 903	691-00903	3
5	seat	033-70508	1
6	soc. setscrew 5/16-24 x 1	312-13160	1
7	hex nut 5/16-24	335-13100	1
8	housing	033-70545	1
9	O-ring 90 S-1 ARP 910	691-00910	1
10	seal piston	033-21767	1
11	O-ring 70 S-1 ARP 012	671-00012	1
12	spring	032-91798	1
13	cone	033-12288	1
14	servo strainer assembly	S13-43240	1
19	O-ring 90 S1 ARP 906	691-00906	1
20	hex plug SAE-6	488-35003	1
21	dowel pin 1/8 x 5/8	324-20810	1
22	O-ring 90 S-1 ARP 904	691-00904	5
23	hollow hex plug SAE-4	488-35001	5
25	plug	488-35049	2
*26	spring pin 3/16 x 3/4	325-12120	2
27	sequence seat	033-70507	2
28	repl. & servo seat	033-70500	4
29	gasket	033-91193	1
30	sequence poppet	033-72378	2
31	servo & dual relief poppet	033-72379	4
32	spring (light weight) 1-9/16" OAL	033-22141	1
33	spring (1-7/16" OAL)	033-70512	2
34	spring retainer	033-70482	1
35	spring (1.09" OAL)	033-71086	3
36	pilot relief assy	S23-12813	1
37	O-ring 70 S-1 ARP 050	671-00050	1
42	retainer plate	033-91422	1
43	button hd. screw 10-24 x 3/4	353-25078	4
45	acorn nut	327-25006	1
46	spring pin 1/8x 3/4	325-08120	2
47	O-ring 70 S-1 ARP 013	671-00013	2
48	O-ring 70 S-1 ARP 014	671-00014	2

ASSEMBLY NUMBER S23-12770

SEAL KIT S23-00135

***Not used after 8-96**

FIGURE 10
valve block assembly(after 7-93)

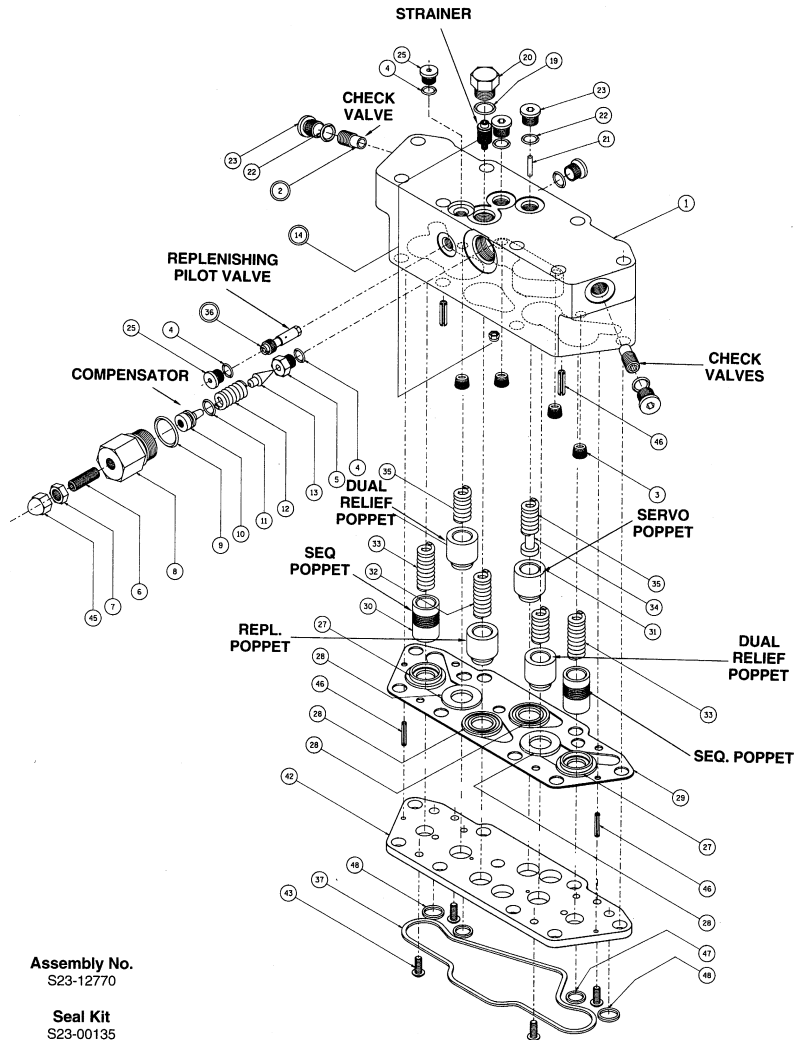

VALVE BLOCK ASSEMBLY
(after 7-93)

Note: Do not use impact tools or over-tighten threaded parts.

Wash and dry all parts. During assembly, lapped and ground surfaces should be kept lubricated with clean oil and protected from nicks or surface damage.

See figure 10: Place valve block (1) with the six poppet valve bores up in order to press two spring pins (26) in position. Spring pins to be .12" (3.04 mm) below the surface of valve block. (Not required after 8-96)

Install four orifice plugs (3) into valve block (1) and tighten in place.

Disassemble the strainer assembly (14) and reassemble per the following steps:

a. Install the orifice screw of strainer assembly (14) into valve cover. Thread elastic stop nut onto the orifice screw and torque to 23 in. lb. (2.6 Nm).

b. Install the strainer support, filter screen, and 6-32 x 1/4 lg. screw. Torque 6-32 screw to 13 in. lb. (1.47 Nm).

Place valve block with poppet valve bores facing up. Position gasket (29) on valve block.

Place springs (33), 1.43" (36.3 mm) into outermost bores at each end of the valve block. Place sequence poppets (30) over these springs. Position seats (27) small shoulder side first over poppets.

Place springs (35), 1.09" (27.7 mm) into bores next to the sequence poppet valves. Place dual relief poppet (31) over these springs. Position seats (28) with the groove side facing up, over poppets.

Place spring (32) 1.56" (39.6 mm) long, into bore next to compensator valve side of block. Install replenish poppet over spring. Position seat (28) with the groove side facing down, over poppet

Carefully position the retainer plate (42) over seats and poppets. Pressing with one hand on the valve block, compress seats, poppets and springs far enough to alternately thread two button head cap screws (43) in far enough to hold the retainer plate. Install the other two screws and alternately tighten screws. Torque to 30 lb. in. (3.39 Nm).

Lubricate O-ring (4) and install onto seat (5). Thread seat into valve block. (Be careful not to damage bore in seat.) Torque to 15 lb.-ft. (20.3 Nm).

Apply petroleum jelly to shank of cone (13) and install spring (12) on cone. Carefully insert cone and spring into valve block positioning point of cone into bore of seat.

Lubricate O-ring (11), install in groove of piston (10) and insert end into spring (12). Install piston in housing guide (8).

Lubricate O-ring (9) and install on housing guide (8) and thread into valve block. Tighten in place.

Thread nut (7) on socket set screw (6) and thread screw into housing guide (8) until it starts to compress spring. Install acorn nut (45) over end of soc. setscrew (6).

Using a small bladed screwdriver, thread the pilot replenishing relief valve assembly (36) into valve block and lightly tighten in place. (Do not over tighten. Over tightening can cause sides of slot to break now or at next removal.

Lubricate O-ring (4) and install on plug (25) and tighten plug in place, two places.

Thread check valve (2) into valve block and lightly tighten in place. (Do not over tighten). Lubricate O-ring (22) and install on plug (23) and tighten in place.

Repeat on other end of valve block.

Lubricate O-ring (19) and install on plug (20) and tighten plug in place.

Install pin (21). Lubricate O-ring (22) and install over plug (23) and tighten in place.

Lubricate two O-rings (22) and install over two plugs (23) and tighten in place.

Using a small hammer, carefully tap spring pins (46) into and through the retainer plate (42). The pins should bottom out in holes leaving enough length sticking out for piloting into the port block.

Lubricate O-ring (47), (48), and (37) and install in the bottom of retainer plate (42).

FIGURE 11
valve block assembly for special
mounting of servovalve (after 7-93)

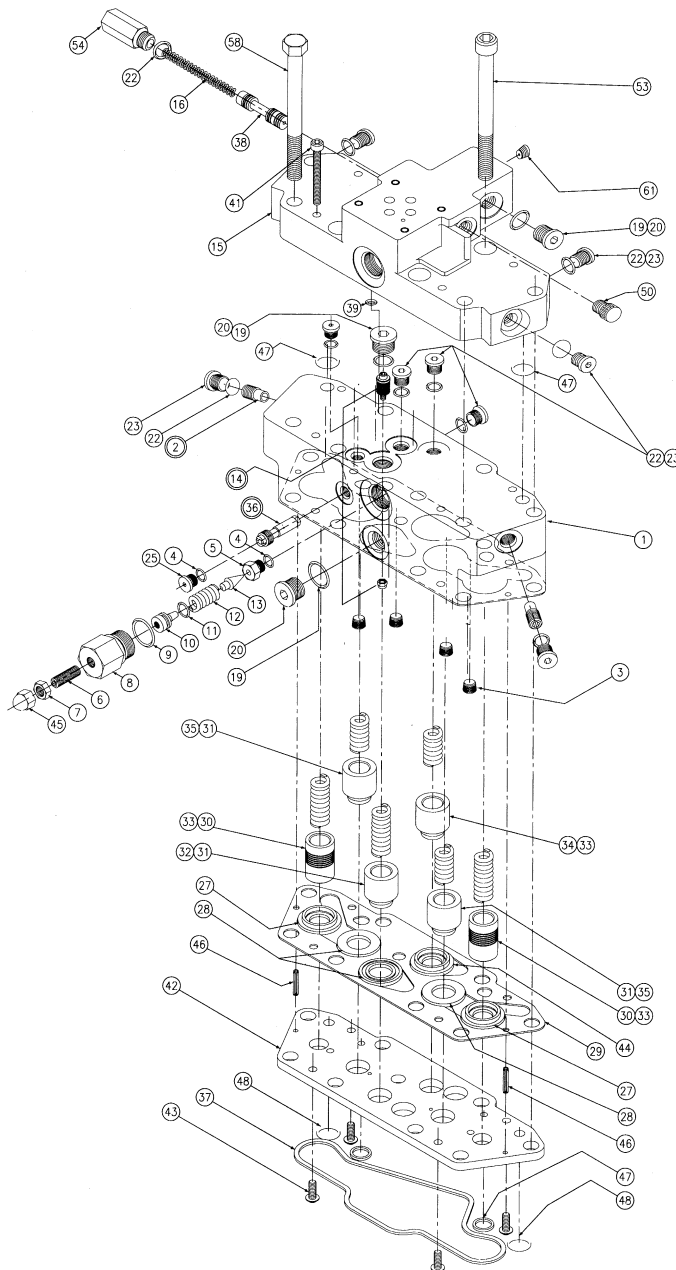

**VALVE BLOCK ASSEMBLY
FOR SPECIAL MOUNTING OF
SERVOVALVE**
(after 7-93)

Note: Do not use impact tools or over tighten threaded parts.

See figure 11: Wash and dry all parts. During assembly, lapped and ground surfaces should be kept lubricated with clean oil and protected from nicks or surface damage.

Place valve block (1) with the six poppet valve bores up in order to press two spring pins (26) in position. Spring pins to be .12" (3.04 mm) below the surface of valve block. (Not required after 8-96)

Install four orifice plugs (3) into valve block (1) and tighten in place.

Disassemble the strainer assembly (14) and reassemble per the following steps:

a. Install the orifice screw of strainer assembly (14) into valve cover. Thread elastic stop nut onto the orifice screw and torque to 23 in. lb. (2.6 Nm).

b. Install the strainer support, filter screen, and 6-32 x 1/4 lg. screw. Torque 6-32 screw to 13 in. lb. (1.47 Nm).

Place valve block with poppet valve bores facing up. Position gasket (29) on valve block.

Place springs (33), 1.43" (36.3 mm) into outermost bores at each end of the valve block. Place sequence poppets (30) over these springs. Position seats (27) small shoulder side first over poppets.

Place springs (35), 1.09" (27.7 mm) into bores next to the sequence poppet valves. Place dual relief poppet (31) over these springs. Position seats (28) with the groove side facing up, over poppets.

Place spring (32) 1.56" (39.6 mm) long into bore next to compensator valve side of block. Install replenish poppet (31) over spring. Position seat (28) with the groove side facing down, over poppet.

Insert spring (33) 1.43" (36.3 mm) into the remaining bore. Place servo poppet (34) over the retainer and spring. Position seat (44) with the tapered bore facing down, over poppet.

Carefully position the retainer plate (42) over seats and poppets. Pressing with one hand on the valve block, compress seats, poppets and springs far enough to alternately thread two button head cap screws (43) in far enough to hold the retainer plate. Install the other two screws and alternately tighten screws. Torque to 30 lb. in. (3.39 Nm).

Lubricate O-ring (4) and install onto seat (5). Thread seat into valve block. (Be careful not to damage bore in seat.) Torque to 15 lb.-ft. (20.3 Nm).

Apply petroleum jelly to shank of cone (13) and install spring (12) on cone. Carefully insert cone and spring into valve block positioning point of cone into bore of seat.

Lubricate O-ring (11), install in groove of piston (10) and insert end of piston into spring (12). Insert piston (11) into housing guide (8).

Lubricate O-ring (9) and install on housing guide (8) and thread into valve block. Tighten in place.

Thread nut (7) on socket set screw (6) and thread screw into housing guide (8) until it starts to compress spring. Install acorn nut (45) over exposed threads.

Using a small bladed screwdriver, thread the pilot replenishing relief valve assembly (36) into valve block and lightly tighten in place. (Do not over tighten. Over tightening can cause sides of slot to break now or at next removal.

Lubricate O-ring (4) and install on plug (25) and tighten plug in place, two places.

Thread check valve (2) into valve block and lightly tighten in place. (Do not over tighten). Lubricate O-ring (22) and install on plug (23) and tighten in place.

Repeat on other end of valve block.

Lubricate O-rings (19) and install on plugs (20) and tighten plug in place, three places.

Lubricate O-rings (22) and install over plugs (23) and tighten in place.

Lubricate O-rings (47) and install in underside of manifold block (15). Carefully place manifold block (15) on top of the valve cover (1) making sure the O-rings are correctly seated. Secure with four soc. hd. cap screws (41) by threading into valve block (1).

Install spring (16) and spool (38) into manifold (15) with the spring guide and spring towards the left side of the manifold (15) when viewing from the top rear.

Lubricate O-ring (22) and install on plug (14). Install plug in manifold (15) over spring (16).

Install orifice plug (61) in manifold (15).

Install temporary plug (50) in 1/4" tube port.

Using a small hammer, carefully tap spring pins (46) into and through the retainer plate (42). The pins should bottom out in holes leaving enough length sticking out for piloting into the port block.

Lubricate O-ring (47), (48) and (37) and install in the bottom of retainer plate (42).

ASSEMBLY PROCEDURES

PARTS LIST FOR FIGURE 11

*valve block assembly for special
mounting of servovalve
(after 7-93)*

item	description	part no.	qty.
1	valve block	033-91335	1
2	check valve assembly	S13-40266	2
3	orifice plug .047" (1.2 mm)	033-91249	4
4	O-ring 90 S-1 ARP 903	691-00903	2
5	seat	033-70508	1
6	soc. setscrew 5/16-24 x 1	312-13160	1
7	hex nut 5/16-24	335-13100	1
8	housing	033-70545	1
9	O-ring 90 S-1 ARP 910	691-00910	1
10	seal piston	036-21767	1
11	O-ring 70 S-1 ARP 012	671-00012	1
12	spring	032-91798	1
13	cone	036-12288	1
14	servo strainer assembly	S13-43240	1
15	manifold	033-54389	1
16	spring (Lee LC-038C-19)	225-92083	1
19	O-ring 90 S-1 ARP 906	691-00906	3
20	hex plug SAE-6	488-35041	3
22	O-ring 90 S-1 ARP 904	691-00904	10
23	hollow hex plug SAE-4	488-35001	9
25	plug (3HP5N-S)	488-35049	2
27	sequence seat	033-70507	2
28	valve seat	033-70500	3
29	lower gasket	033-91193	1
30	sequence poppet	033-72378	2
31	valve poppet	033-72379	3
32	spring (light weight)	033-22141	1
33	spring (1 7/16" OAL)	033-70512	3
34	servo relief poppet	033-54398	1
35	spring (1" OAL)	033-71086	2
36	pilot relief assy	S23-12699	1
37	O-ring 70 S-1 ARP 050	671-00050	1
38	spool	033-54392	1
39	O-ring 90 S-1 ARP 008	691-00008	1
41	soc. hd. cap screw 10-24 x 1-1/4	358-10180	4
42	retainer plate	033-91422	1
43	button hd. screw 10-24 x 3/4	353-25078	4
44	servo relief seat	033-54399	1
45	acorn nut	327-25006	1
46	spring pin 1/8 x 3/4	325-08120	2
47	O-ring 70 S-1 ARP 013	671-00013	4
48	O-ring 70 S-1 ARP 014	671-00014	2
50	plug 7/16-20	449-00013	1
53	screw, soc. hd. 3/8-16 x 4	358-16360	4
54	plug	035-54400	1
58	hex hd. screw	306-40132	4
61	orifice plug .047" (1.2 mm)	033-25528	1

ASSEMBLY NUMBER S23-12776

SEAL KIT S23-04226

***Not used after 8-96**

PARTS LIST FOR FIGURE 12

adapter assembly

item	description	part no.	qty.
1	adapter - SAE A with shuttle pad	033-91015	1
	adapter - SAE B with shuttle pad	033-57967	
2	coupling	033-57963	1
3	insert - SAE A	033-57965	1
	insert - SAE B	033-57964	
4	tube - isolation	033-57966	1
5	gasket - O-ring 70 S-1 ARP 147	671-00147	1
6	retaining ring	356-65128	1
7	gasket - O-ring 70 S-1 ARP 033	671-00033	1
8	wave spring	225-92093	1
9	hex hd. cap screw	306-40088	4
10	gasket - square section	691-10131	2
11	gasket - O-ring 70 S-1 ARP 152 (with SAE A)	671-00152	1
	gasket - O-ring 70 S-1 ARP 155 (with SAE B)	671-00155	
12	washer	350-10136	4

FIGURE 12
adapter assembly

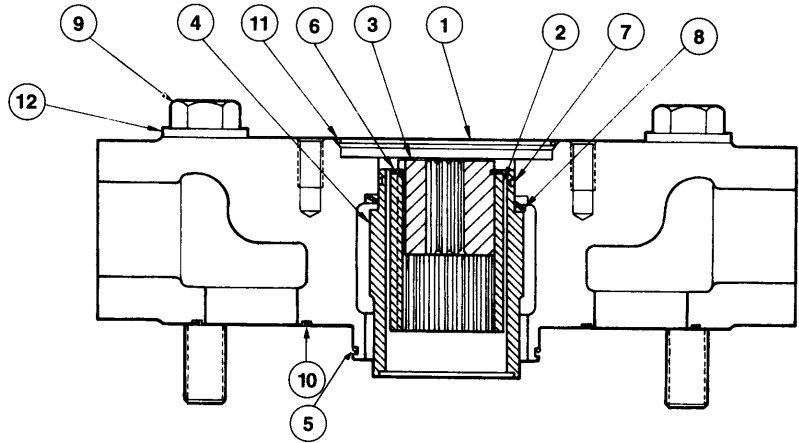

ADAPTER ASSEMBLY

See figure 12: Place wave spring, (8) over isolation tube (4). Lube O-ring (7) and assemble to isolation tube. Place isolation tube against pressure plate.

Lube O-ring (5) and assemble to adapter (1).

Lube tetraseals (10). Insert into adapter block and carefully assemble adapter block to port block. (See figure 17) Using screws (9) and washers (12) to hold adapter block in place, torque to 150 ft.-lb. (203 Nm).

Insert retaining ring (6) into groove of coupling insert (3).

Coupling (2) with coupling insert (3) and retaining ring (6) may be installed to end of auxiliary shaft when external pump is mounted.

CHECK VALVE ASSEMBLY

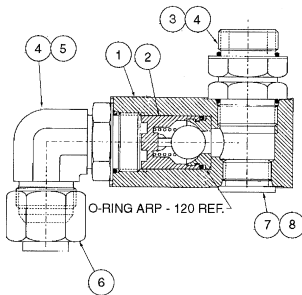

FIGURE 13
check valve

See figure 13: Lube O-ring on cartridge (2). Insert cartridge in body (1). Insert O-ring (4) on fitting (5). Install fitting in body (1) till it bottoms on cartridge, then back out to align with SAE-4 side connection. Lock in position to body (1). Insert O-rings (4) on fitting (3). Install fitting in body; with nut and washer to the outside. Install cap (6) on fitting (5). Install check valve in bottom drain connection of pump housing as shown in figure 17.

PARTS LIST FOR FIGURE 13

check valve S23-15222

item	description	part no.	qty.
1	body	033-91718	1
2	check valve cartridge	513-50155	1
3	fitting	492-15374	1
4	O-ring, 90 S-1 ARP 916	691-00916	3
5	elbow	494-15012	1
6	cap	482-55010	1
7	plug	48-35014	1
8	O-ring, 90 S-1 ARP 912	691-00912	1

PARTS LIST FOR FIGURE 14

shuttle valve S23-11966

item	description	part no.	qty.
1	shuttle block	033-57752	1
2	pilot valve (see figure 15)	S26-22865	1
3	spool	033-57180	1
4	spring stop washer	033-57182	2
5	sleeve	036-27549	1
6	piston	036-32902	1
7	spring	036-27547	1
8	spring	033-57181	1
9	O-ring, 90 S-1 ARP 125	691-00125	2
10	O-ring, 90 S-1 ARP 026	691-00026	1
11	tetraseal	691-10221	2
12	plug	488-35024	2
13	screw, HHC 1/2-13 x 3-1/2	306-40224	4
14	screw, HHC 3/8-24 x 1 3/4	359-15220	3
15	O-ring, 90 S-1 ARP 915	691-00916	2
16	plug	488-35014	1
17	O-ring, 90 S-1 ARP 912	691-00912	1

seal kit S23-15089

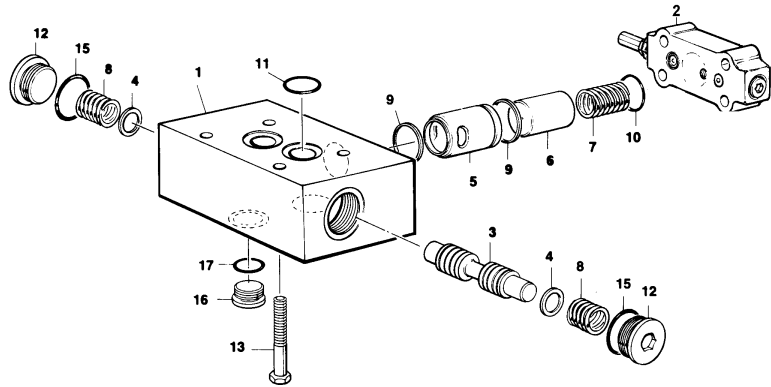

FIGURE 14
shuttle valve

SHUTTLE VALVE ASSEMBLY
S23-11966 (external drain)

See figure 14: Lube spool (3) and insert it into valve body (1). When the spool is fully engaged, move the spool back and forth a few times to check for smooth operation. Spool must move freely in body bore.

Install spring stop (4) into one end of valve body (1). Make sure it is seated properly. Insert spring (8) into valve body (1) over the spool (3). Install plug (12) and O-ring (15) into the valve body (1). Repeat on the other end of valve body

Lube O-ring (9) and install into valve body (1). Lube another O-ring (9) and install over sleeve (5). Insert sleeve into bore of valve body (1).

Insert piston (6) into sleeve (5) and place spring (7) into piston (6). Lube O-ring (10) and place onto the sleeve (5).

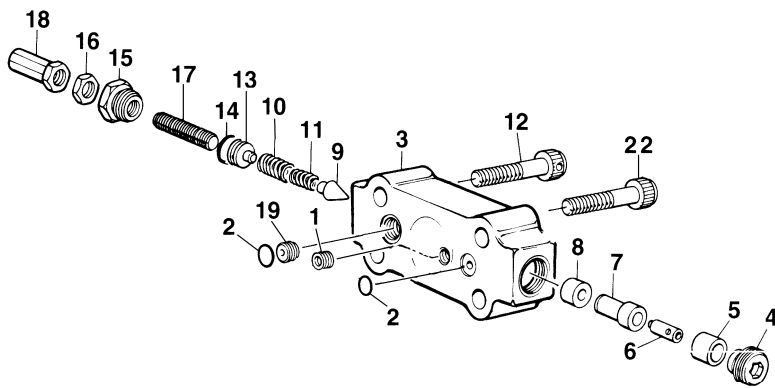

FIGURE 15
pilot valve for shuttle valve

PILOT VALVE ASSEMBLY
S26-22867 (external drain)

See figure 15: Insert plug (19) into inside hole on spring end of cap. Insert orifice plug (1) on center hole in cap.

Insert seat (8) into cap (3) and seat in bottom of bore. Install small end first of block (7) into bore and against seat. Install small end first of piston (6) into block (7). Install spacer (5) and secure in place with setscrew (4).

Install spring (11) onto cone (9). Install spring (10) over spring (11) and insert into cap (3). Install O-ring (14) on piston (13) and insert small end into springs. Install plug (15), screw (17) and nut (16). Grease and install O-rings (2).

Set per requirement and install acorn nut (18). Run wire which comes with valve cap subassembly through holes in special screw and acorn nut. Twist ends together.

Mount pilot valve sub-assembly on shuttle block. Use three SHC screws (22) and the one drilled head screw (12). Position the drilled head screw closest to the acorn nut. Torque screws to 50 ft.-lb. (68 Nm).

MOUNTING SHUTTLE ASSEMBLY TO ADAPTER

See figure 14: Lube O-rings (11) and install in body. Install shuttle valve on adapter (see figure 16) using 4 screws (13). Torque to 75 ft.-lbs (102 Nm).

ASSEMBLY PROCEDURES

PARTS LIST FOR FIGURE 15

*pilot valve assembly
S23-12007 (external drain)*

item	description	part no.	qty.
1	orifice	036-25528	1
2	O-ring, 90 S-5 ARP 013	695-00013	2
3	cap	036-38910	1
4	setscrew	312-35051	1
5	spacer	036-27548	1
6	piston	036-11694	1
7	block	036-11710	1
8	seat	036-11692	1
9	cone	036-12288	1
10	spring	036-32465	1
11	spring	036-85514	1
12	screw, SHC, 3/8-24 x 1 3/4 (drilled)	036-36749	1
13	piston	036-21767	1
14	O-ring, 90 S-5 ARP 012	695-00012	1
15	plug	036-21765	1
16	hex nut, 5/16-24	333-13001	1
17	screw, SS, 5/16-24 x 1 5/8	312-13200	1
18	acorn nut	036-33474	1
19	hex soc. plug	431-90104	1
22	screw, SHC, 3/8-24 x 1 3/4	359-15220	3

PARTS LIST FOR FIGURE 16

final assembly of pump

item	description	part no.	qty.
1	no. 3 splined shaft assy. design C (see fig. 1)	S23-15212	1
	no. 2 keyed shaft assy. design C (see fig. 1)	S23-15213	
4	shaft seal, inner, design B and C (CW rotation)	620-82104	1
	shaft seal, inner, design B and C (CCW rotation)	620-82105	
4A	shaft seal, outer, design C	620-82101	1
5	O-ring 70 S-1 ARP 249 design A	671-00249	1
	O-ring 70 S-1 ARP 251 design B and C	671-00251	
5A	O-ring 70 S-1 ARP 234 design B (inner)	671-00234	1
	O-ring 70 S-1 ARP 237 design C (inner)	671-00237	
5B	O-ring 70 S-1 ARP 239 design B (outer)	671-00239	1
	O-ring 70 S-1 ARP 044 design C (outer)	671-00044	
6	seal retainer design C	033-91709	1
7	Nyltite washer	631-45007	4
8	screw	306-40021	4
9	servo stem	033-71616	1
10	soc. hd. cap screw	359-09240	2
11	balance plate	033-70546	1
12	spacer	033-71247	2
13	soc. hd. cap screw	359-09180	2
14	Nyltite washer	631-45007	8
15	hex washer hd. screw 3/8-16 x 1-1/4	353-25018	8
16	output control assembly	see below	1
17	input control assembly	see next page	1
18	hex hd. cap screw 3/8-16 x 3-1/4	306-40184	8
*19	O-ring 70 S-1 ARP 017	671-00017	2
*20	O-ring 70 S-1 ARP 048	671-00048	1
21	hex hd. screw	306-40016	2
**22	pump TB006 CW rotation	024-51095	1
	pump TB006 CCW rotation	024-51096	
23	check valve assembly 5 psi (design C)	S23-15223	1
24	rear adapter, SAE-A for shuttle valve	S23-12362	1
	rear adapter, SAE-B for shuttle valve	S23-12670	
25	hex hd cap screw	306-40224	4
26	shuttle valve, external drain (see figure 14)	S23-11966	1
27	spring, bearing preload	033-91713	1
28	elbow	495-10000	1
29	fitting	494-15016	1
30	O-ring, 90 S-1 ARP 904	691-00904	2
31	hose assembly	486-15160	1

*Some controls use gasket 033-91058 in lieu of O-rings (cast iron covers)

Powdered metal covers have grooves for O-rings 671-00017, 671-00048.

**Note: Gear pump 512-42023 (CW) or 512-42024 (CCW) used on earlier designs.

Any pump with SAE-A or SAE-B mounting may be used, with appropriate adapter (24).

OUTPUT CONTROLS

DESCRIPTION

standard volume indicator	S13-42064
torque limiter, both sides A/B mounting	S23-12999
torque limiter CW "B" mtg, CCW "A" mtg.	S23-12998
torque limiter CW "A" mtg, CCW "B" mtg.	S23-12300

INPUT CONTROLS

DESCRIPTION	part no.
10* screw adjustment CW "B" mtg, CCW "A" mtg.	S23-12327
CW "A" mtg, CCW "B" mtg.	S23-12328
2H (three position cylinder control)	S23-12358
40* (spring centered rotary servo)	S23-12344
4A* (spring centered rotary servo with adjustable stops)	S23-12325
4B* (spring centered rotary servo with automatic brake valve)	S23-12343
4C* (spring ctd. rotary servo, adj. stops, automatic brake valve)	S23-12324
5A* (electrohydraulic stroker, adj. stops, "O" deadband)	S23-12413
5C* (electrohydraulic stroker, adj. stops, automatic brake valve)	S23-12414
8A* (proportional hydraulic stroker, adjustable stops)	S23-12268
8C* (proportional hydraulic stroker, adj. stops, automatic brake valve)	S23-12820
9A* (electrohydraulic stroker, adjustable stops)	S23-12667
9C* (electrohydraulic stroker, adj. stops, automatic brake valve)	S23-12925

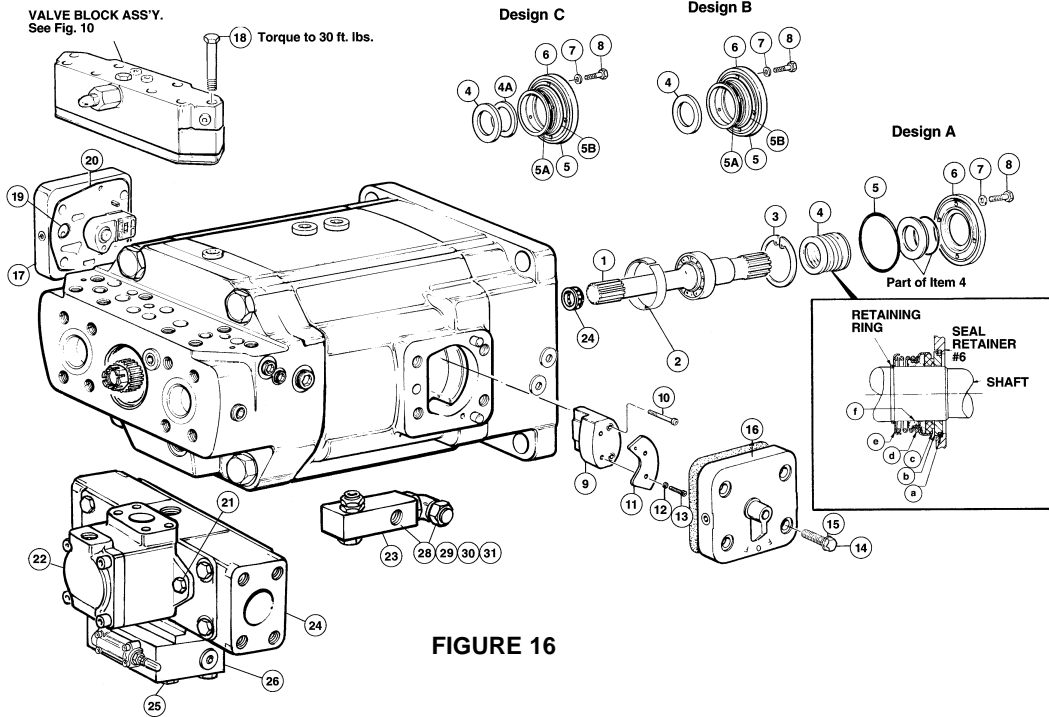
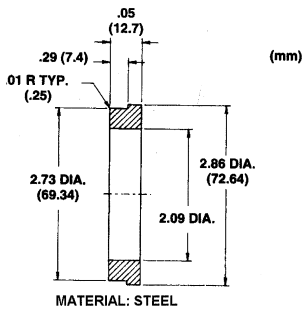

FIGURE 16



FINAL ASSEMBLY OF PUMP T-2

See fig 16: Wash and dry retainer and lip seals. Apply Loctite #518 gasket sealer (or equivalent) to O.D. of seal and to seal retainer bores. Position the outer lip seal (4A) in the retainer with lip facing inward. Using the small end of tool T-2, press till seal face contacts the shoulder. Position the inner lip seal (4) in the retainer with double lip facing inward. Check that rotation arrow coincides with shaft rotation. Using large end of tool T-2, press till seal face contacts its shoulder.

Attach seal installation sleeve T-3 to the end of the shaft with M12 x 1,75 x 30 mm lg. metric screw. Carefully slip seal retainer with seals over the end of the shaft and over the shaft. Remove sleeve and replace with tool T-4 to hold seal retainer/shaft/bearing assembly together for assembly in the pump.

Place the pump in a horizontal position with the ports horizontal.

Remove the screws used to temporarily hold the cam/cradle assembly against the mounting flange. Apply heavy grease to the bearing preload spring (27) to retain it, and install it in the end of the shaft.

Install the shaft/bearing and seal retainer assembly with preload spring (27) into the mounting flange and cradle. Be careful that the spring remains in position, and that the cam/cradle assembly remains on the locating pins.

Place Nyltite gaskets (7) on screws (8). Align the seal retainer and mounting flange bolt holes. Install bolts (8), alternately tightening to 30 ft.-lb. (40.8 Nm). The shaft retainer tool T-4 may now be removed.

**C - MOD SHAFT SEAL
INSTALLATION TOOLS**

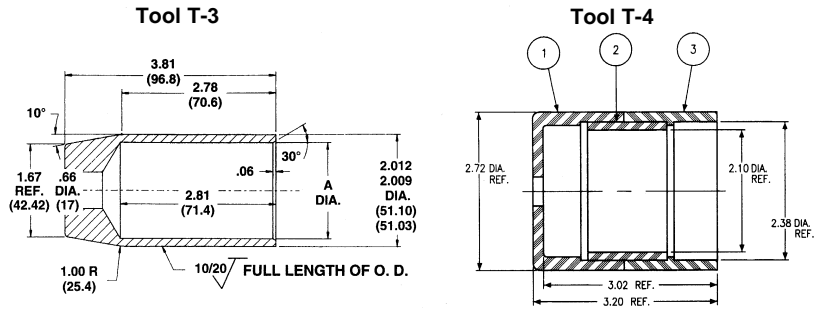

shaft	A diameter
splined	1.723/1.722 (43.76/43.74 mm)
keyed	1.752/1.751 (44.50/44.48 mm)

item	material
1	ABS cap for 2" sch. 40 pipe
2	ABS 2" sch. 40 pipe
3	ABS coupling for 2" sch. 40 pipe

**A - MOD SHAFT SEAL
REPLACEMENT**

Note: Seal installation must be completed quickly to avoid the rubber friction ring seizing on the shaft. **Warning:** When installing a new mechanical shaft seal, exercise care to insure that all of the parts fit together properly. This is particularly important if the seal was once assembled and disassembled for any reason. If the rubber boot, item (f) grips the shaft and doesn't slide on the shaft as it is disassembled, then the spring, item (d), can disengage the shell, item (h) from the band (g) so that they do not re-engage properly when reassembled. Be sure the shell and the band are properly engaged before reassembling the seal, and stays engaged during assembly.

See figure 16. Position pump so that it rests on the port block face.

Install the shaft and bearing assembly (1) in the mounting flange and cradle. Be certain that there are no burrs or sharp edges on shaft seal area of the shaft.

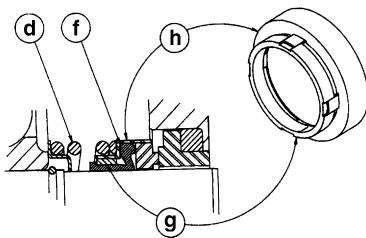

Use the shim (2) that results in least clearance around the shaft bearing. Remove the two screws that were temporarily used to hold the cradle in the mounting flange.

Install the retaining ring (3) in the mounting flange.

Use the operating oil to lubricate the shaft, shaft seal boot, carbon seat, ceramic face, square seal and seal retainer O-ring.

Lubricate and install the O-ring (5) and stationary parts of the shaft seal (4) into the seal retainer (6). Install new "Nyltite" gaskets (7) on the four bolts (8).

After lubricating shaft and seal boot, slip seal boot onto shaft until spring retainer bottoms on bearing, being very careful not to damage the carbon seat.

Depress the seal retainer only far enough to start the screws and tighten evenly in a criss-cross pattern. Torque to 30 ft.-lbs (40.8 Nm).

Using a strap wrench, check to see that the shaft rotates smoothly and take corrective action as necessary.

A - MOD SHAFT SEAL

**B - MOD SHAFT SEAL
REPLACEMENT**

See fig 16: Wash and dry retainer and lip seals. Apply Loctite #518 gasket sealer (or equivalent) to O.D. of seal and to seal retainer inner seal bore. Position the inner lip seal (4) in the retainer with lip facing inward. Using the small end of tool T-2, press till seal face contacts the shoulder.

Attach seal installation sleeve T-3 to the end of the shaft with M12 x 30 mm lg metric screw. Carefully slip seal retainer with seals over the end of the shaft and over the shaft.

Lubricate and install O-rings (5), (5A) and (5B) into the seal retainer (6). Install new "Nyltite" gaskets (7) on the four bolts (8). Torque evenly in a criss-cross pattern to 30 ft.-lbs (40.8 Nm). Remove installation sleeve.

**COUNTERBALANCE SERVO
STEM ASSEMBLY**

Install balance stem (9) on rocker cam using two #10-32 screws (10). Torque to 70 in.-lb. (7.91 Nm).

Place the two spacers (12) on the two screws (13) and insert through the balance plate (11).

Insert these parts through the opening in the side of the housing assembly and position the screws over the two tapped holes in the rocker cam. Torque screws to 70 in.-lb. (7.91 Nm)

Lubricate O-rings (19 and 20) and install in grooves in covers (Some covers use gasket 033-91058).

CONTROL COVER INSTALLATION

Install the cover assemblies (16 and 17) over the dowel pins on the housing pads and secure with seals (14) and screws (15). Torque to 30 ft. lb. (40.8 Nm).

Note: The input cover assembly must be installed on the right hand side of the housing on pumps with "B" suffix. Install the input cover assembly on the left hand side on models with "A" suffix.

VALVE BLOCK INSTALLATION

Apply petroleum jelly or grease to O-ring grooves on underside of valve block, figures 10 or 11 as applicable. Insert O-rings in grooves. Place valve block on mating surface of port block, making certain that O-rings remain in place. Install screws (18) and uniformly torque to 30 ft. lb. (40.8 Nm).

HOSE INSTALLATION

Install O-rings (30) to elbow (28) and fitting (29). Install elbow (28) in the DG2 port on the mounting flange. Install 45° fitting in the check valve body (23). Connect hose assembly (31) to these two fittings.

INSTRUCTIONS FOR REPLENISHING ISOLATION PLUG

CAUTION: The isolation plug included with pump is to be installed ONLY if an external filter circuit is provided. **DO NOT** operate unit with the isolation plug installed unless an external line has been provided.

When the external filter circuit IS NOT used, discard the isolation plug.

When the external filter circuit IS used install the isolation plug under the plug in the face of the port block. Use a 3/16" hex. wrench by 4" minimum length. Insert the isolation plug and tighten to 80 - 120 in.-lb. (9.04 - 13.56 Nm) torque. The adapter block must be removed to install the isolation plug.

CAUTION: the filter must have bypass and bypass indicator. Denison Hydraulics recommends it be sized to four times the expected flow.

Isolation plug kit: S13-44178 plug, 1/8 pipe plug, part no. 431-90200

FIGURE 17
port locations

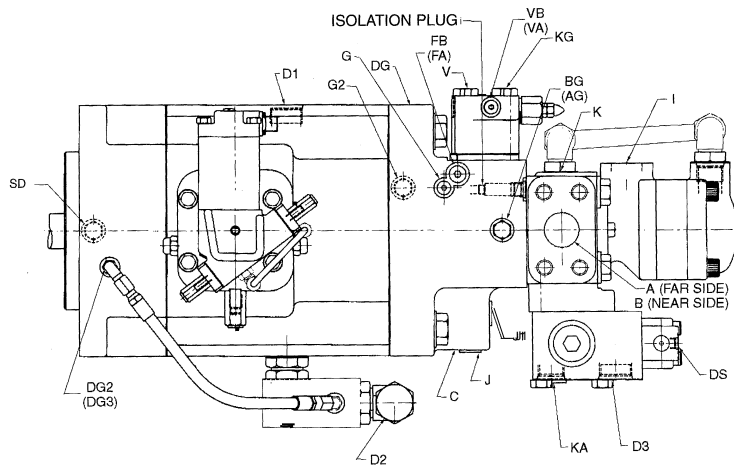

PORT DESCRIPTION & SIZE

- ports A & B - SAE code 62 split flange

in.	1-1/2
mm	(38.1)
- port AG, BG (A&B system gage) straight thread O-ring seal SAE -6
- port C (aux. pump inlet) SAE code 61 split flange

in.	1-1/4
mm	(31.8)
- port D1 (aux. case drains) straight thread O-ring seal SAE -16
- port D2 (case drain) 37° flared SAE -16
- port D3 (repl relief drain) straight thread O-ring seal SAE -16
- port DG (case gage) straight thread O-ring seal SAE -6
- port DS (shuttle repl pilot drain) straight thread O-ring seal SAE -4
- port FA, FB (control pressures) straight thread O-ring seal SAE -6
- port G (servo pressure both sides) st. thd. O ring seal SAE -4
- port G2 (servo pressure A side) straight thread O-ring seal SAE -8
- port I (external aux. pump inlet) SAE code 61 split flange

in.	1-1/4
mm	(38.1)
- port J (internal aux. pump outlet) SAE -8
- port J1 (internal aux. pump outlet) SAE -10
- port K (aux. repl inlet) straight thread O-ring seal SAE -16
- port KG (repl. gage) straight thread O-ring seal SAE -6
- port V (common vent) straight thread O-ring seal SAE -4
- port VA, VB (A&B individual vents) straight thread O-ring seal SAE -4

GAGE PRESSURE RANGES

AG, BG & V: 6000 PSI (68.9 bar) gage for A or B port
 DG: 200 PSI (13.7 bar) gage for case port
 KG: 500 PSI (35 bar) gage for replenishment port
 G, G2: 1000 PSI (68.9 bar) gage for servo port.

Caution: When installing system pressure gage (V), make certain loose modulating pin is retained in the port

Note: Do not install gage in servo filter line when isolation plug is installed without "T" fitting. FAILURE TO DO SO WILL RESULT IN AUXILIARY SHAFT FAILURE.

CONVERSION OF A OR B MOD TO C MOD

The following parts are required to convert a keyed shaft pump of "A" or "B" mod to "C" mod:

item	description	part no.	qty.
1	O-ring 90 S-1 ARP 902	691-00902	2
2	dowel pin	324-23216	2
3	mounting flange	033-91711	1
4	rocker cradle	033-91712	1
5	CW rotation shaft,bearing and seal assembly, keyed	S23-15219	1
	CCW rotation shaft,bearing and seal assembly, keyed	S23-15350	
6	mounting flange gasket	033-91076	1
7	port block gasket	033-91079	1
8	O-ring 70 S-1 ARP 144	671-00144	1
9	O-ring 70 S-1 ARP 129	671-00129	1
10	plug,SAE-4	488-35061	2
11	spring, bearing preload	033-91713	1
12	seal kit, std valve block	S23-00135	1
13	O-ring, 90 S-1, ARP 904	691-00904	8
14	locating sleeve	033-72664	4
15	shuttle valve seal kit	S23-15089	1
16	check valve assembly, including hose/fittings	S23-15223	1
17	O-ring, 90 S-1 ARP 912	691-00912	2
18	nameplate	033-71907	1
19	screw, drive	320-10203	4
20	molded seal	606-25040	2
21	O-ring, 90 S-1 ARP 125	691-00125	2
22	O-ring, 90 S-1 ARP 916	691-00916	1
23	O-ring, 90 S-1 ARP 908	691-00908	3
24	O-ring 90 S-1 ARP 906	691-00906	4
25	O-ring 70 S-1 ARP 147	671-00147	1
26	O-ring 70 S-1 ARP 033	671-00033	1
27	O-ring 70 S-1 ARP 905	691-00905	1
29	O-ring 90 S-1 ARP 910	691-00910	1
30	Tetraseal 90 S-1 ARP 131	691-10131	2
31	O-ring 70 S-1 ARP 152	671-00152	1
32	O-ring 70 S-1 ARP 155	671-00155	1
33	Nyltite washer	631-45007	8
34	gasket, control cover	033-91058	2
35	O-ring 70 S-1 ARP 017	671-00017	2
36	O-ring 70 S-1 ARP 048	671-00048	2

CW rotation kit S23-15218

CCW rotation kit S23-15349

GENERAL REQUIREMENTS

1. Maximum runout between pump shaft and electric motor shaft .003 T.I.R. (.076 mm).
2. Electric motor speed - 1800 RPM.
3. Inlet temperature - 130° ± 10°F. (54° ± 4°C)
4. Inlet condition

Main pump	100 to 150 PSI. (6.9 to 10.3 bar).
External pump and gerotor	10" Hg to 5 PSI. (254 mm Hg. to 0.34 bar)
5. Case pressure 65 PSI ± 10 PSI (4.5 ± .69 bar)
6. Fluid - 200 SSV (43cSt) at 100° F. (37.8° C)

BASIC PUMP TEST

1. Mount pump on test stand. Connect system lines and auxiliary pump inlet line to pump. Connect case drain line to flowmeter.
2. With system pressure set at minimum, start electric motor. Observe servo and replenishing pressures. Shut off if pressures do not appear quickly.
3. Rotate pump input control shaft. The servo control should control pump displacement through its full range. Set pump displacement for full volume, and adjust system pressure for 1000 PSI (69 bar). Check and record system flow and case drain flow above and below center. Monitor loop temperature.

	11.0 in ³	14.0 in ³
maximum system flow	86 GPM (325.5 l/min.)	110 GPM (416.3 l/min.)
maximum case drain flow	2.5 GPM (9.5 l/min.)	2.5 GPM (9.5 l/min.)

4. Back out compensator adjusting screw until unit is fully compensated (count number of turns). Observe volume indicator and stroke rotary servo input shaft from full to full position on each side of center. Indicator should remain on or very near zero position. If compensator functions normally, return compensator adjusting screw to its original position and proceed with step 5.

CAUTION: Do not over-tighten adjusting screw.

5. Cycle pump at 10 sec. intervals - full volume above center to full volume below center as follows:

- 8 min. at 1000 PSI (69 bar)
- 5 min. at 2500 PSI (172 bar)
- 3 min. at 5000 PSI (345 bar)

(Pumps with screw adjustment controls do not need to be cycled).

6. Adjust system pressure to 5000 PSI (345 bar). Set pump displacement at full volume. Check and record system flow and case drain flow above and below center.

	11.0 in ³	14.0 in ³
minimum system flow	72 GPM (272.5 l/min.)	96 GPM (363.3 l/min.)
maximum case drain flow	4.5 GPM (17 l/min.)	5.5 GPM (20.8 l/min.)

7. Raise shuttle relief setting above 350 psi (24.1 bar). Set pump to compensate at 5000 psi (345 bar). Servo pressure should be at least 650 psi (45.5 bar). Check and record replenishing flow.

Minimum flow 21.8 GPM (82.5 l/m).

8. Set pump to compensate at minimum PSI. Check and record replenishing and servo pressure.

Servo pressure-Minus Case Pressure 455 to 570 PSI (31.3 to 39.3 bar).
 Repl. Pressure-Minus Case Pressure- 350 PSI ± 20 PSI (24.1 ± 1.4 bar)

If pressures are incorrect, remove replenishing relief valve pilot and increase or decrease pressure as required. (One full turn on adj. screw will cause pressure to change approximately 50 PSI (3.4 bar). Re-torque locknut to 20-25 in/lb. (2.3-2.8 Nm.)

Note: There is no servo relief valve adjustment. Increasing or decreasing repl. pressure will cause both servo and repl. pressure to change by the same amount.

9. Set pump to compensate at 5000 PSI (345 bar). Record repl. and servo pressure.

Servo pressure-minus case pressure 660 to 770 PSI (45.5 to 53.1 bar)

Repl. Pressure-minus case pressure 350 PSI \pm 20 PSI (24.1 \pm 1.4 bar)

10. Set pump to compensate at minimum PSI. Servo pressure should return to 455 to 570 PSI (31.3 to 39.3 bar).

11. With the pump at full displacement, lower the shuttle relief setting to 220 psi. \pm 20 psi. (15.2 \pm 1.4 bar). Cycle the pump from full to full. Replenish pressure should rise to 350 psi. (24.1 bar) each time the pump crosses over center stroke, and drop to 220 psi (15.2 bar) when pump is on stroke.

12. Adjust pump displacement for full volume and adjust system pressure to 5000 PSI (345 bar) Adjust compensator from maximum to minimum pressure in 1000 psi (69 bar) intervals. At each pressure, stroke rotary servo input shaft to the full position on each side of center. Cam indicator should remain on or very near the zero position with no oscillation. System pressure should not vary from port "A" to port "B" more than 150 PSI (10.3 bar) and not oscillate. Minimum compensator pressure should be under 500 PSI (34.5 bar).

13. Set pump to compensate at 1000 PSI (69 bar). Increase and decrease system pressure above and below compensator setting. When system pressure is above compensator setting, the pump should de-stroke and not oscillate. When the system pressure is below the compensator setting, the pump should stroke to full volume. Repeat at 5000 psi. (345 bar). Make final compensator setting at 1000 psi UNLESS OTHERWISE SPECIFIED.

14. Check pump for external leaks. No external leaks permitted.

15. After all tests are complete re-torque main housing bolts to 350 ft.-lbs. (476 Nm).

Note: After completing above test, proceed with pump control test and adjustment per controls manual (S1-AM030). Continue pump test after testing control.

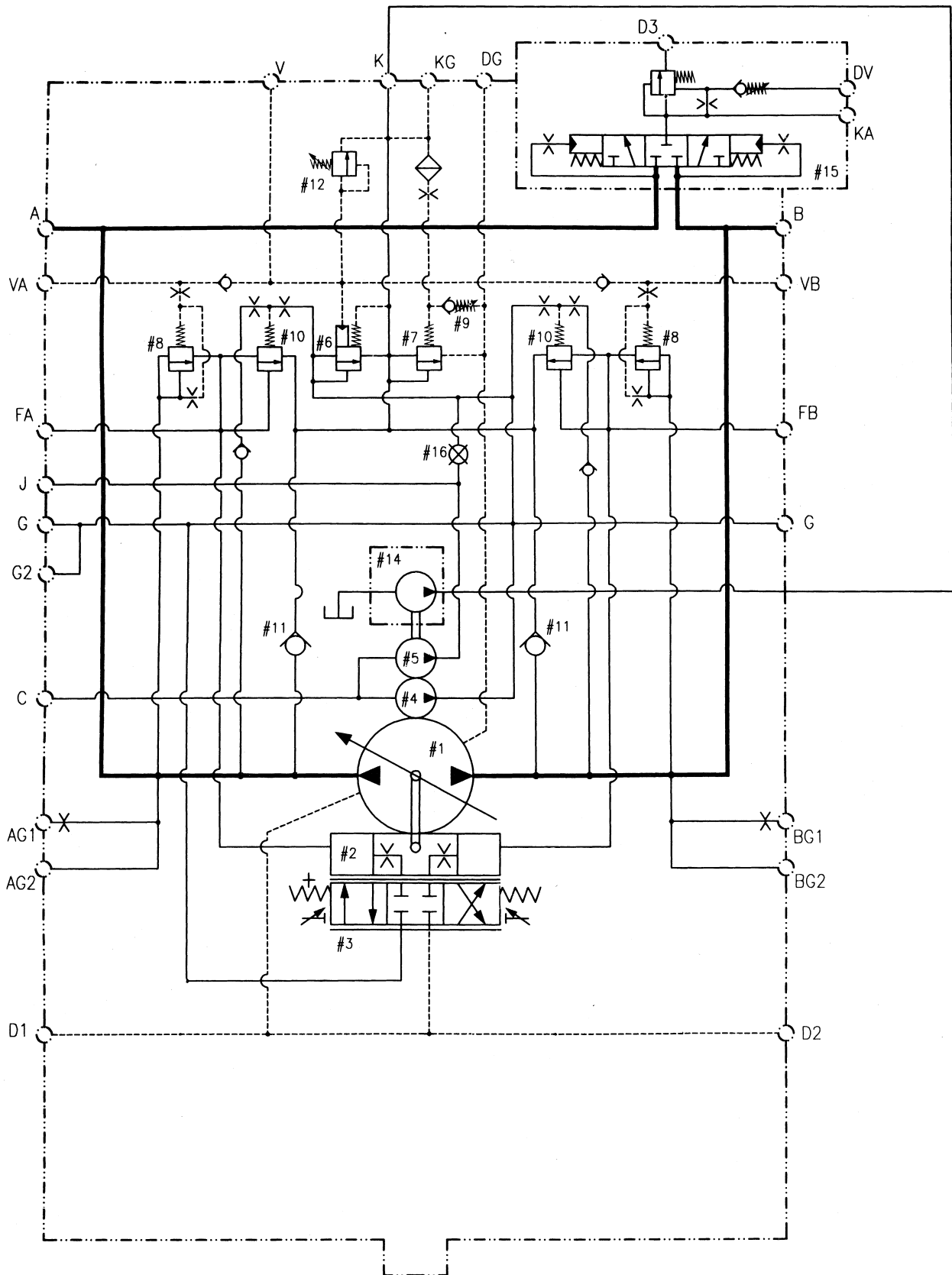

ITEM	DESCRIPTION
#1	PISTON PUMP
#2	VANE CHAMBERS
#3	PRIMARY CONTROL
#4	INTERNAL SERVO SUPPLY PUMP
#5	INTERNAL REPLENISHING SUPPLY PUMP
#6	SERVO PRESSURE VALVE (MODULATED BY OPERATING PRESSURE)
#7	REPLENISHING RELIEF VALVE
#8	SEQUENCE RELIEF VALVE
#9	REPLENISHING RELIEF PILOT VALVE
#10	DUAL LEVEL RELIEF VALVE
#11	REPLENISHING CHECK VALVE
#12	COMPENSATOR RELIEF VALVE
#14	EXTERNAL AUX. BOOST PUMP
#15	SHUTTLE VALVE
#16	1/8" NPTF PIPE PLUG INSTALLED ONLY IF PORT "J" CONNECTS TO PORT "K" EXTERNALLY

CIRCUIT SHOWN WITH
SCREW ADJ. CONTROL ON "A" SIDE

PORT	DESCRIPTION	SIZE
A, B	HIGH PRESSURE SYSTEM PORTS	4-BOLT PAD FOR SAE-1 1/2" 6000 PSI
AG1, BG1	SYSTEM PRESSURE GAGE	SAE-6 STRAIGHT THREAD
AG2, BG2	SYSTEM PRESSURE GAGE	SAE-4 STRAIGHT THREAD
C	INTERNAL AUX. PUMP INLET	SAE-20 STRAIGHT THREAD
DG	CASE PRESSURE GAGE	SAE-6 STRAIGHT THREAD
D1, D2	CASE DRAINS	SAE-16 STRAIGHT THREAD
G	SERVO GAGE CONN.	SAE-4 STRAIGHT THREAD
G2	ALTERNATE SERVO GAGE CONN.	SAE-8 STRAIGHT THREAD
J	AUXILIARY PUMP OUTLET	SAE-10 STRAIGHT THREAD
K	AUX. REPLENISHMENT INLET & FILTER RETURN	SAE-16 STRAIGHT THREAD
KG	REPLENISHING GAGE CONN.	SAE-6 STRAIGHT THREAD
FA	CONTROL CHAMBER GAGE, A SIDE	SAE-6 STRAIGHT THREAD
FB	CONTROL CHAMBER GAGE, B SIDE	SAE-6 STRAIGHT THREAD
V	COMPENSATOR VENT, BOTH SIDES	SAE-4 STRAIGHT THREAD
VA	COMPENSATOR VENT, A SIDE	SAE-4 STRAIGHT THREAD
VB	COMPENSATOR VENT, B SIDE	SAE-4 STRAIGHT THREAD
KA	SHUTTLE RELIEF INLET	SAE-12 STRAIGHT THREAD
DV	EXTERNAL DRAIN PILOT VALVE	SAE-4 STRAIGHT THREAD
D3	SHUTTLE DRAIN	SAE-16 STRAIGHT THREAD

P 11 S - 2R1C - 4A2 - A - 00 - 0B1 - M2 - XXXXX

Pump Series

Displacements, max.

11 - 11.0 in³/rev., 98 cc/rev.
14 - 14.0 in³/rev., 119 cc/rev.

S - external drive version with shuttle valve

Shaft

SAE 177-4,
2 - 44-1 (formerly SAE-E keyed)
3 - 50-4 (formerly SAE-F Splined)

Shaft rotation (viewed from shaft end)

R - CW; L - CCW

Fluid class

1 - compatible w/Buna N
4 - compatible w/EPR
5 - compatible w/Viton

Design letter

A - Mechanical seal
C - Double lip seal

Primary controls

1 - Screw adjustment
2 - Cylinder control
4 - Rotary servo (spring centered w/trimmer)
5 - Electrohydraulic stroker
7 - Servovalve & feedback device
8 - Hydraulic stroker
9 - Electrohydraulic stroker

(All include rotary servo, pressure compensator override & displ. indicator)

Primary control options

0 - None
A - Adjustable maximum volume stops
B - Automatic brake control & bypass
C - A & B above, together
D - 10 GPM Servovalve w/feedback potentiometer
E - 10 GPM Servovalve w/feedback RVDT
F - 10 GPM Servovalve w/potentiometer & manual override - w/4A2 control
G - 10 GPM Servovalve w/2RVDT & manual override - w/4A2 control
H - 3 position 2A control

Secondary controls

2 - Aux. replenishment port on centerline - (std.)
4 - Dampened torque limiter and aux. replenishing port

Allowable controls: P_S: 1A2, 1A4, 102, 104, 2A2, 2A4, 4A2, 4A4, 4C2, 4C4, 5A2, 5A4, 5C2, 5C4, 7D2, 732, 7F2, 7G2, 8A2, 8A4, 8C2, 8C4, 9A2, 9A4, 9C2, 9C4

Designates special

External mounting

0 - pump not mounted
1 - pump mounted (must be separately specified)

External drive

A - SAE 82-2, 16-4 (formerly "A")
B - SAE 101-2, 22-4 (formerly "B")

Internal pump

0 - servo 1.07 in³/rev. (17.5 cc/rev.) repl. 1.07 in³/rev. (17.5 cc/rev.)
X - none

Control features

500 control

00 - with deadband
01 - without deadband

700 control

00 - w/0 manual override shutoff
01 - w/manual override shut-off

800 control

00 - 75 - 350 psi (5 - 24 bar)
01 - 75 - 435 psi (5 - 30 bar)
02 - 100 - 375 psi (6.9 - 25.9 bar)
03 - 150 - 400 psi (10.3-27.6 bar)
04 - 75 - 250 psi (5.2 - 17.2 bar)

900 control

00 - 24 VDC
01 - 12 VDC

FOR ALL OTHER CONTROLS USE 00

control location

A - command on port A side
B - command on port B side (displacement indicator or potentiometer on opposite side)

DEFINITION & UNIT

<i>displacement</i>	$\text{in}^3/\text{rev} \times 16.387 = \text{cm}^3/\text{rev}$	$\text{cm}^3/\text{rev} \times 0.06102 = \text{in}^3/\text{rev}$
<i>flow</i>	$\text{gpm} \times 3.78 = \text{L}/\text{min}$	$\text{L}/\text{min} \times 0.2642 = \text{gpm}$
<i>power</i>	$\text{hp} \times 0.7457 = \text{kW}$	$\text{kW} \times 1.341 = \text{hp}$
<i>torque</i>	$\text{lb}\cdot\text{ft} \times 1.3567 = \text{Nm}$	$\text{Nm} \times 0.7376 = \text{lb}\cdot\text{ft}$
<i>pressure</i>	$\text{lbs}/\text{in}^2 \text{ (psi)} \times 0.06895 = \text{bar}$ $\text{lbs}/\text{in}^2 \text{ (psi)} \times 6.895 = \text{kPa}$	$\text{bar} \times 14.50 = \text{lbs}/\text{in}^2 \text{ (psi)}$ $\text{kPa} \times 0.1450 = \text{lbs}/\text{in}^2 \text{ (psi)}$
<i>weight</i>	$\text{lb} \times 0.4536 = \text{kg}$	$\text{kg} \times 2.205 = \text{lbs}$
<i>force</i>	$\text{lb} \times 4.448 = \text{N}$	$\text{N} \times 0.2248 = \text{lbs}$
<i>volume</i>	$\text{in}^3 \times 16.387 = \text{cm}^3$	$\text{cm}^3 \times 0.06102 = \text{in}^3$
<i>area</i>	$\text{in}^2 \times 6.452 = \text{cm}^2$	$\text{cm}^2 \times 0.1550 = \text{in}^2$
<i>length</i>	$\text{in} \times 25.4 = \text{mm}$	$\text{mm} \times 0.03937 = \text{in}$
<i>temperature</i>	$\text{degree F} - 32 = \text{°C}$ 1.8	$1.8 \times \text{°C} + 32 = \text{°F}$
<i>viscosity</i>	$\text{cSt} \times 1.0 = \text{mm}^2/\text{sec}$ $(\text{SSU}-14) \div 4.25 \approx \text{cSt}$	$\text{mm}^2/\text{sec} \times 1.0 = \text{cSt}$ $\text{cSt} \times 4.25 + 14 \approx \text{SSU}$

FLUID POWER FORMULAS

<i>Pump input torque</i>	<i>lbs. in.</i>	$\frac{\text{pressure}(\text{psi}) \times \text{displacement} (\text{in}^3/\text{rev})}{2\pi \times \text{mech. eff.}}$
<i>Pump input power</i>	<i>hp</i>	$\frac{\text{rpm} \times (\text{in}^3/\text{rev}) \times (\text{psi})}{395934 \times \text{overall eff.}}$
<i>Pump output flow</i>	<i>U.S. gpm</i>	$\frac{\text{rpm} \times (\text{in}^3/\text{rev}) \times \text{volumetric eff.}}{231}$
<i>Fluid motor speed</i>	<i>rpm</i>	$\frac{231 \times \text{flow rate}(\text{U.S. gpm}) \times \text{volumetric eff.}}{\text{displacement} (\text{in}^3/\text{rev})}$
<i>Fluid motor torque</i>	<i>lbs. in.</i>	$\frac{\text{pressure}(\text{psi}) \times \text{displacement} (\text{in}^3/\text{rev}) \times \text{mech. eff.}}{2\pi}$
<i>Fluid motor power</i>	<i>hp</i>	$\frac{\text{rpm} \times (\text{in}^3/\text{rev}) \times (\text{psi}) \times \text{overall eff.}}{395934}$
(metric)		
<i>Pump input torque</i>	<i>Nm</i>	$\frac{\text{pressure}(\text{bar}) \times \text{displacement} (\text{cm}^3/\text{rev})}{20\pi \times \text{mech. eff.}}$
<i>Pump input power</i>	<i>kW</i>	$\frac{\text{rpm} \times (\text{cm}^3/\text{rev}) \times (\text{bar})}{600000 \times \text{overall eff.}}$
<i>Pump output flow</i>	<i>Lpm</i>	$\frac{\text{rpm} \times (\text{cm}^3/\text{rev}) \times \text{volumetric eff.}}{1000}$
<i>Fluid motor speed</i>	<i>rpm(min⁻¹) (tr/mn)</i>	$\frac{1000 \times \text{flow rate} (\text{Lpm}) \times \text{volumetric eff.}}{\text{displacement} (\text{cm}^3/\text{rev})}$
<i>Fluid motor torque</i>	<i>Nm</i>	$\frac{\text{pressure}(\text{bar}) \times \text{displacement} (\text{cm}^3/\text{rev}) \times \text{mech. eff.}}{20\pi}$
<i>Fluid motor power</i>	<i>kW</i>	$\frac{\text{rpm} \times (\text{cm}^3/\text{rev}) \times (\text{bar}) \times \text{overall eff.}}{600000}$

"The product information specifications and descriptions contained in this catalog have been compiled for the use and convenience of our customers from information furnished by the manufacturer, and we cannot and do not accept any responsibility for the accuracy or correctness of any description, calculation, specification or information contained herein. No such description, calculated, specified or information regarding the products being sold has been made part of the basis of the bargain nor has same created or amounted to an express warranty that the products would conform thereto. **We are selling the goods and merchandise illustrated and described in this catalog on an as is basis and disclaim any implied warranty, including any warranty of merchantability or warranty of fitness for any particular purposes whatsoever, with respect to the goods and merchandise sold.** All manufacturer warranties shall be passed on to our customers, but we shall not be responsible for special, indirect, incidental or consequential damages resulting from the use of any of the products or information contained or described in the catalog."

International Distributors

In Europe :

Cyprus
Czech Republic
Hungary
Poland
Rumania
Russia
Slovakia
Slovenia (Croatia, Bosnia, Macedonia)
The Faroe Islands
Greece
Iceland
Norway
Portugal
Switzerland
Turkey
Yugoslavia (Serbia)

In Africa :

Algeria
Egypt
Ivory Coast
Morocco
South Africa
Tunisia

In Middle East :

Iran
Israel
Lebanon
Pakistan
Qatar
Saudi Arabia
Kuwait
United Arab Emirates
State of Bahrain
Jordan Kingdom

In Far East :

Indonesia
Korea
Malaysia
New Zealand
Philippines
Thailand

Other European, Middle East, African countries, contact:

Denison Hydraulics S.A.
14 route du bois blanc
BP 539
18105 Vierzon, France
Tel : +33 (2) 48 53 01 20
Fax : +33 (2) 48 53 01 46

Asia-Pacific

Australia
Denison Hydraulics PTY
41-43 St Hilliers Road
P.O.Box 192
Auburn N.S.W. 2144, Australia
Tel : +61 (2) 9646 5200
Fax : +61 (2) 9643 1305

Hong Kong

Denison Hydraulics Ltd.
Unit 6A, 33/F Cable TV Tower
9 Hoi Shing Road, Tsuen Wan
NT, Hong Kong
Tel : +852 2498 8381
Fax : +852 2499 1522

Japan

Denison Japan Inc.
4-2-1 Tsujido-Shinmachi
Fujisawa 251, Japan
Tel : +81 (466) 35-3050
Fax : +81 (466) 35-2019

People Republic of China

Shanghai Denison Hydraulics Engineering Ltd.
Room 8018, No. 601, Zhang Yang Road.
Pudong, New Area
Shanghai 200120, P. R. China
Tel : +86 (21) 58205042
Fax : +86 (21) 58205014

Singapore

Denison Hydraulics PTE LTD
11 Lorong Tukang Dua,
Singapore 2261
Tel : +65 268 7840
Fax : +65 268 7847

Europe

Austria

Denison Hydraulics GmbH
Zweig Niederlassung Linz
Haibachstraße 69
4061 Pasching, Austria
Tel : +43 (72 29) 48 87
Fax : +43 (72 29) 6 30 92

Benelux

Denison Hydraulics Benelux B.V.
Pascalstraat 100
3316 GR Dordrecht, Holland
Tel : +31 (78) 6179 900
Fax : +31 (78) 6175 755

Denmark

Denison Hydraulics Denmark A/S
Industrikrogen 2
2635 Ishøj, Denmark
Tel : +45 (4371) 15 00
Fax : +45 (4371) 15 16

Finland

Denison Lokomec
Polunmäenkatu 22
P.O.Box 116
33721 Tampere, Finland
Tel : +358 (3) 3575 100
Fax : +358 (3) 3575 111

France

Denison Hydraulics S.A.
14 route du bois blanc
BP 539
18105 Vierzon, France
Tel : +33 (2) 48 53 01 20
Fax : +33 (2) 48 75 02 91

Great Britain

Denison Hydraulics UK LTD
Kenmore Road
Wakefield 41, Industrial Park
Wakefield, WF2 OXE
West Yorkshire, England
Tel : +44 (1924) 826 021
Fax : +44 (1924) 826 146

Germany

Denison Hydraulics GmbH.
Herderstrasse 26
40721 Hilden, Germany
Tel : +49 (2103) 940 600
Fax : +49 (2103) 940 888

Italy

Denison Hydraulics Srl
Via Le Europa 68
20090 Cusago (MI) Milanese,
Italy
Tel : +39 (02) 90330-1
Fax : +39 (02) 90390694/5/6

Spain

Denison Hydraulics S.A.
Gomis 1
08023 Barcelona, Spain
Tel : +34 (93) 418 4887
Fax : +34 (93) 211 6507

Sweden

Denison Hydraulics Svenska AB
Sporregatan 13
213 77 - Malmö, Sweden
Tel : +46 (40) 21 04 40
Fax : +46 (40) 21 47 26

North America

Canada

Denison Hydraulics Canada Inc.
2320-1 Bristol Circle, Unit 1
Oakville, ON L6H 5S3, Canada
Tel : +1 (905) 829-5800
Fax : +1 (905) 829-5805

Mexico, Central America, South America, Caribbean countries

Denison Hydraulics Inc.
7850 N.W. 146 St., Ste. 512
Miami, FL 33016, USA
Tel : +1 (305) 362-2246
Fax : +1 (305) 362-2246

USA

Denison Hydraulics Inc.
14249 Industrial Parkway
Marysville, OH 43040, USA
Tel : +1 (937) 644-3915
Fax : +1 (937) 642-3738

USA - Literature Request

Denison Literature Support
1100 W. Bagley Rd., Ste. 101
Berea OH 44017 USA
Tel : +1 (800) 551-5956
Fax : +1 (440) 824-2005
E-mail:
literature@denisonhydraulics.com

Contact your local distributor or call toll-free for the distributor nearest you at **800-551-5956**

DENISON Hydraulics

<http://www.denisonhydraulics.com>