

# DENISON HYDRAULICS M4E - M4SE - M4E1 - M4SE1

vane-type motor / Flügelzellen Motor

moteur à palettes / motore a palette

motore de paletas

## service information

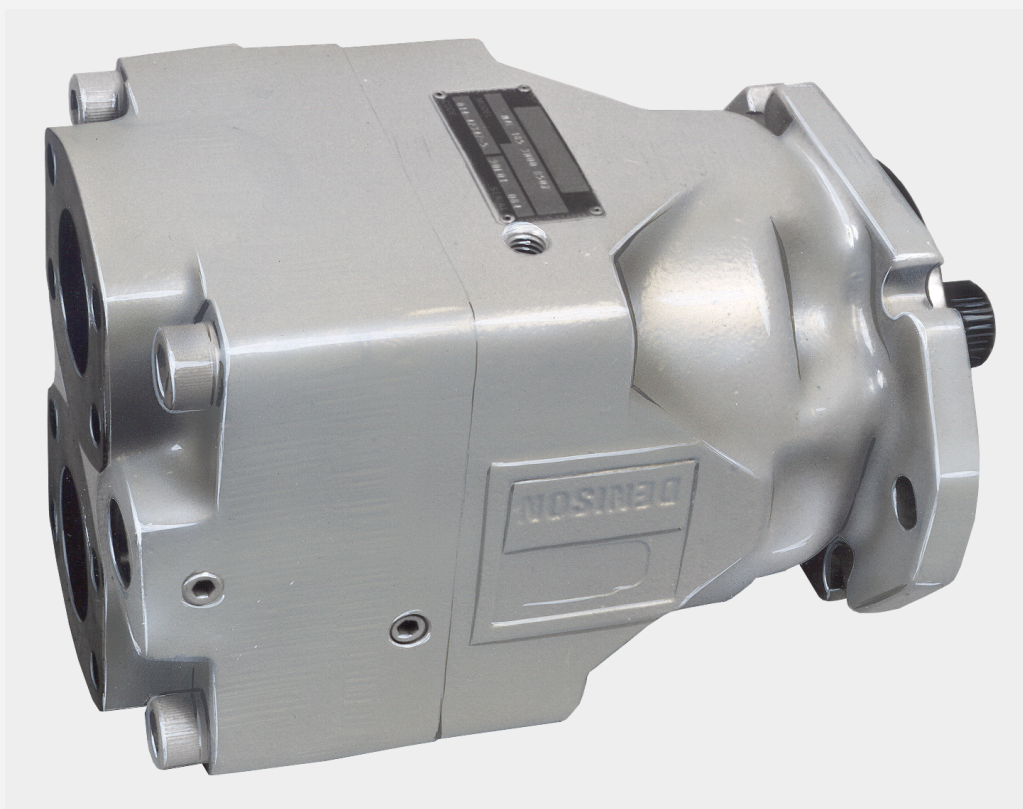

Publ. S2 - ML1503 - A

10 / 98 / 2500 / FB

Replace : S2 - ML 153 - A

**DENISON** | **Hydraulics**

Recommended repair kits and assy's are bolt printed  
 Empfohlene Austausch - Baugruppen sind fett gedruckt  
 Les pochettes de rechange recommandées sont imprimées en caractères gras  
 I kit di ricambio consigliati sono indicati in grassetto  
 Los juegos de reparacion recomendados y los conjuntos, estan en negrita

**M4E - M4E1  
 M4SE - M4SE1**

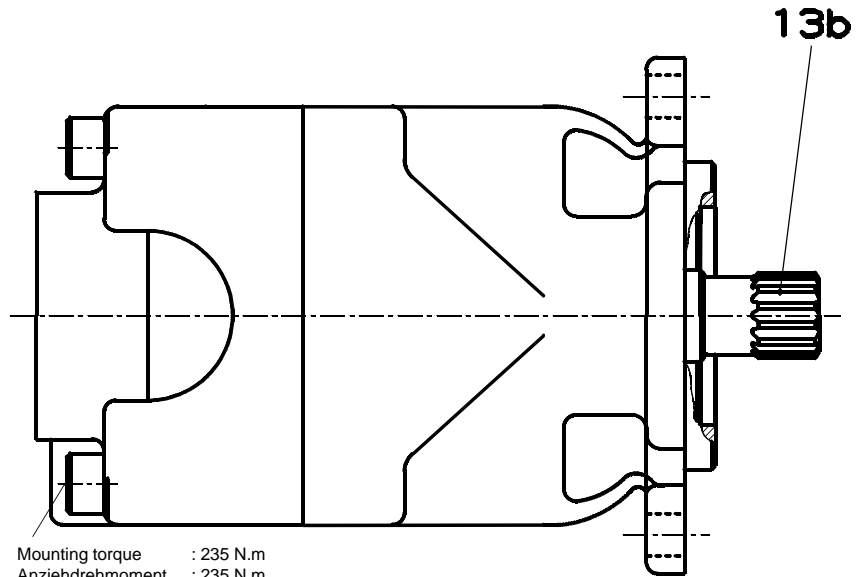
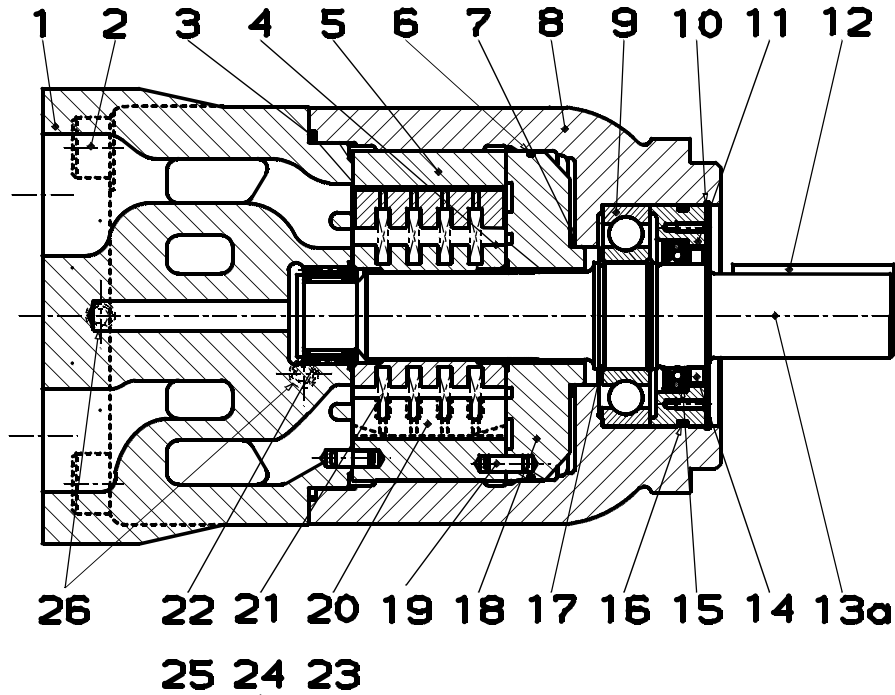

Mounting torque : 235 N.m  
 Anziehdrehmoment : 235 N.m  
 Couple de serrage : 235 N.m  
 Coppia di serraggio : 235 N.m  
 Par de apriete : 235 N.m

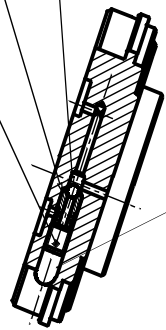

Mounting torque : 11,5 to 12,6 N.m  
 Anziehdrehmoment : 11,5 bis 12,6 N.m  
 Couple de serrage : 11,5 à 12,6 N.m  
 Coppia di serraggio : 11,5 a 12,6 N.m  
 Par de apriete : 11,5 a 12,6 N.m

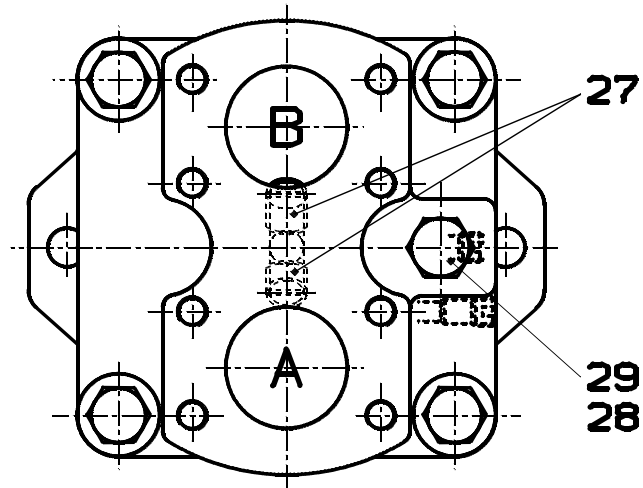

Item Pos. Ref. Pos. Pos.	Description <i>Descrizione</i>	Benennung <i>Descripción</i>	Description		Part N° Teil Nr. Code N° Cod. N° Referencia M4E - M4E1	Part N° Teil Nr. Code N° Cod. N° Referencia M4SE - M4SE1	Qty Stück Qté Q.tà Cant.
1	End cap 4-bolts UNC (SAE drain) (M4E - M4SE) <i>Coperchio UNC 4 fori (drenaggio SAE) (M4E - M4SE)</i>	Deckel UNC Flansch (SAE Leckölschluß) (M4E - M4SE) <i>Tapa UNC 4 agujeros (drenaje SAE) (M4E - M4SE)</i>	Chapeau 4 trous UNC (drain SAE) (M4E - M4SE)	F	034.71288	034.71288	1
	End cap thd. port SAE (SAE drain) (M4E - M4SE) <i>Coperchio filettature SAE (drenaggio SAE) (M4E - M4SE)</i>	Deckel SAE Gewinde (SAE Leckölschluß) (M4E - M4SE) <i>Tapa rosca SAE (drenaje SAE) (M4E - M4SE)</i>	Chapeau orifices taraudés SAE (drain SAE) (M4E - M4SE)	F	034.71290	034.71290	1
	End cap 4-bolts UNC (BSPP drain) (M4E - M4SE) <i>Coperchio UNC 4 fori (drenaggio BSP) (M4E - M4SE)</i>	Deckel UNC Flansch (R Leckölschluß) (M4E - M4SE) <i>Tapa UNC 4 agujeros (drenaje BSP) (M4E - M4SE)</i>	Chapeau 4 trous UNC (drain BSPP) (M4E - M4SE)	F	034.66375	034.66375	1
	End cap 4-bolts UNC (SAE drain) (M4E1 - M4SE1) <i>Coperchio UNC 4 fori (drenaggio SAE) (M4E1 - M4SE1)</i>	Deckel UNC Flansch (SAE Leckölschluß) (M4E1 - M4SE1) <i>Tapa UNC 4 agujeros (drenaje SAE) (M4E1 - M4SE1)</i>	Chapeau 4 trous UNC (drain SAE) (M4E1 - M4SE1)	F	034.71289	034.71289	1
	End cap thd. port SAE (SAE drain) (M4E1 - M4SE1) <i>Coperchio filettature SAE (drenaggio SAE) (M4E1 - M4SE1)</i>	Deckel SAE Gewinde (SAE Leckölschluß) (M4E1 - M4SE1) <i>Tapa rosca SAE (drenaje SAE) (M4E1 - M4SE1)</i>	Chapeau orifices taraudés SAE (drain SAE) (M4E1 - M4SE1)	F	034.71291	034.71291	1
2	Screw <i>Vite</i>	Schraube <i>Tornillo</i>	Vis		358.24380	358.24380	4
3	O.ring <i>Guarnizione torica</i>	Runddichtring <i>Anillo tórico</i>	Joint torique	D	675.00257	675.00257	1
4	Rotor <i>Rotore</i>	Rotor <i>Rotor</i>	Rotor	A	034.70074	034.70074	1
5	Cam ring 153 <i>Anello camma 153</i>	Hubring 153 <i>Aro volumetrico 153</i>	Came 153	A	034.70076	034.70417	1
	Cam ring 185 <i>Anello camma 185</i>	Hubring 185 <i>Aro volumetrico 185</i>	Came 185	A	034.70077	034.70418	1
	Cam ring 214 <i>Anello camma 214</i>	Hubring 214 <i>Aro volumetrico 214</i>	Came 214	A	034.70078	034.70419	1
6	Sq. section seal <i>Guarnizione</i>	Dichtring <i>Junta seccion cuadrada</i>	Joint section carrée	D	695.10250	695.10250	1
7	Sq. section seal <i>Guarnizione</i>	Dichtring <i>Junta seccion cuadrada</i>	Joint section carrée	D	695.10229	695.10229	1
8	Housing <i>Corpo</i>	Gehäuse <i>Cuerpo</i>	Carter		034.71278	034.71278	1
9	Ball bearing <i>Cuscinetto a sfera</i>	Kugellager <i>Cojinete de bolas</i>	Roulement à billes	BC	230.03308	230.03308	1
10	Retaining ring <i>Anello elastico</i>	Sicherungsring <i>Aro retencion</i>	Circlips		356.30354	356.30354	1
11	Retainer seal <i>Anello elastico</i>	Dichtungsträger <i>Aro retencion</i>	Chapeau porte joint		034.70069	034.70069	1
12	Key (code 1) <i>Chiavetta (codice 1)</i>	Paßfeder (Typ 1) <i>Chaveta (codigo 1)</i>	Clavette (code 1)	B	034.46754	034.46754	1
13a	Shaft (keyed) (code 1) <i>Albero a chiavetta (codice 1)</i>	Paßfederwelle (Typ 1) <i>Eje chaveteado (codigo 1)</i>	Arbre à clavette (code 1)	B	034.71088	034.71088	1
13b	Shaft (splined) (code 3) <i>Albero scanalato (codice 3)</i>	Vielkeilwelle (Typ 3) <i>Eje estriado (codigo 3)</i>	Arbre à cannelures (code 3)	C	034.71089	034.71089	1
14	Felt wiper <i>Feltro pulitore</i>	Filzring <i>Felpa</i>	Joint feutre	D	605.10020	605.10020	1

Item Pos. Ref. Pos.	Description <i>Descrizione</i>	Benennung <i>Descripcion</i>	Description		Part N° Teil Nr. Code N° Cod. N° Referencia M4E - M4E1	Part N° Teil Nr. Code N° Cod. N° Referencia M4SE - M4SE1	Qty Stück Qté Qtá Cant.
15	Shaft seal <i>Paraolio</i>	Simmerring <i>Retén eje</i>	Joint d'arbre	D	637.00003	637.00003	1
16	O.ring <i>Guarnizione torica</i>	Runddichtring <i>Anillo tórico</i>	Joint torique	D	675.00236	675.00236	1
17	Round section ring <i>Anello elastico</i>	Sicherungsring <i>Anillo tórico</i>	Anneau	BC	034.70866	034.70866	2
18	Port plate pressure <i>Piatto distributore anter.</i>	Steuerplatte <i>Plato de presion</i>	Plaque pression	E	034.53344	034.53344	1
19	Dowel pin <i>Spina</i>	Fixierstift <i>Pasador</i>	Goupille		324.22012	324.22012	2
20	Vane <i>Paletta</i>	Flügel <i>Paleta</i>	Palette	A	034.70075	034.70075	10
21	Spring vane <i>Molla</i>	Feder für Flügel <i>Muelle paleta</i>	Ressort de palette	A	034.49743	034.49743	40
22	Needle bearing <i>Cuscinetto a rulli</i>	Nadellager <i>Cojinete de agujas</i>	Roulement à aiguilles		230.82134	230.82134	1
23	Ball <i>Sfera</i>	Kugel <i>Bola</i>	Bille d'acier	E	201.06001	201.06001	1
24	Adaptor valve <i>Adattatore</i>	Kugel ventil <i>Valvula adaptadora</i>	Adapteur valve	E	034.53346	034.53346	1
25	Screw <i>Vite</i>	Schraube <i>Tornillo</i>	Vis	E	312.35056	312.35056	1
26	Plug <i>Tappo</i>	Stopfen <i>Tapon</i>	Bouchon	F	431.90400	431.90400	2
27	Check valve (M4E1 - M4SE1) <i>Valvola di ritegno (M4E1 - M4SE1)</i>	Rückschlagventil (M4E1 - M4SE1) <i>Valvula de retención (M4E1 - M4SE1)</i>	Clapet (M4E1 - M4SE1)	F	S14.27259	S14.27259	2
28	O.ring (M4E1 - M4SE1) <i>Guarnizione torica (M4E1 - M4SE1)</i>	Runddichtring (M4E1 - M4SE1) <i>Anillo tórico (M4E1 - M4SE1)</i>	Joint torique (M4E1 - M4SE1)	FD	675.00908	675.00908	1
29	Plug (M4E1 - M4SE1) <i>Tappo (M4E1 - M4SE1)</i>	Stopfen (M4E1 - M4SE1) <i>Tapon (M4E1 - M4SE1)</i>	Bouchon (M4E1 - M4SE1)	F	488.35002	488.35002	1
	<b>REPAIR KIT KIT DI RICAMBIO</b>	<b>AUSTAUSCH-BAUGRUPPEN CONJUNTO REPARACION</b>	<b>POCHETTES RECHANGES</b>				
A	<b>Kit 153 Cartuccia 153</b>	<b>Pumpeneinsatz 153 Juego 153</b>	<b>Cartouche 153</b>		S14.27464	S14.28946	1
A	<b>Kit 185 Cartuccia 185</b>	<b>Pumpeneinsatz 185 Juego 185</b>	<b>Cartouche 185</b>		S14.27465	S14.28947	1
A	<b>Kit 214 Cartuccia 214</b>	<b>Pumpeneinsatz 214 Juego 214</b>	<b>Cartouche 214</b>		S14.27466	S14.28948	1
B	<b>Shaft and bearing ass'y (code 1) Ins. albero (codice 1)</b>	<b>Baugruppe (Welle u. Lager) (Typ 1) Conjunto eje (codigo 1)</b>	<b>Arbre à clavette et roulement ass. (code 1)</b>		S14.27469	S14.27469	1
C	<b>Shaft and bearing ass'y (code 3) Ins. albero (codice 3)</b>	<b>Baugruppe (Welle u. Lager) (Typ 3) Conjunto eje (codigo 3)</b>	<b>Arbre à cannelures et roulement ass. (code 3)</b>		S14.27470	S14.27470	1
D	<b>Seal kit (S5) Serie guarnizioni (S5)</b>	<b>Dichtringsatz (S5) Juego de juntas (S5)</b>	<b>Pochette de joints (S5)</b>		S14.42336.5	S24.42336.5	1

Item Pos. Ref. Pos. Pos.	Description <i>Descrizione</i>	Benennung <i>Descripcion</i>	Description	Part N° Teil Nr. Code N° Cod. N° Referencia M4E - M4E1	Part N° Teil Nr. Code N° Cod. N° Referencia M4SE - M4SE1	Qty Stück Qté Q.tà Cant.
E	Port plate-pressure ass'y <i>Ins. piatto distributore anter.</i>	Steuerplatte <i>Conjunto plato dist.</i>	Plaque pression ass.	S14.27471	S14.27471	1
F	End cap ass'y <i>Ins. coperchio</i>	Gehäuse baugruppe <i>Conjunto tapa</i>	Chapeau arrière ass.			
	4-bolts UNC (SAE drain) (M4E - M4SE) <i>UNC 4 fori (drenaggio SAE) (M4E - M4SE)</i>	UNC Flansch (SAE Leckölanschluß) (M4E - M4SE) <i>UNC 4 agujeros (drenaje SAE) (M4E - M4SE)</i>	4 trous UNC (drain SAE) (M4E - M4SE)	S14.42330	S14.42330	1
	SAE thd. port (SAE drain) (M4E - M4SE) <i>Filettature SAE (drenaggio SAE) (M4E - M4SE)</i>	SAE Gewinde (SAE Leckölanschluß) (M4E - M4SE) <i>Rosca SAE (drenaje SAE) (M4E - M4SE)</i>	Orifices taraudés SAE (drain SAE) (M4E - M4SE)	S14.42331	S14.42331	1
	4-bolts UNC (BSPP drain) (M4E - M4SE) <i>UNC 4 fori (drenaggio BSP) (M4E - M4SE)</i>	UNC Flansch (R Leckölanschluß) (M4E - M4SE) <i>UNC 4 agujeros (drenaje BSP) (M4E - M4SE)</i>	4 trous UNC (drain BSPP) (M4E - M4SE)	S14.97018	S14.97018	1
	4-bolts UNC (SAE drain) (M4E1 - M4SE1) <i>UNC 4 fori (drenaggio SAE) (M4E1 - M4SE1)</i>	UNC Flansch (SAE Leckölanschluß) (M4E1 - M4SE1) <i>UNC 4 agujeros (drenaje SAE) (M4E1 - M4SE1)</i>	4 trous UNC (drain SAE) (M4E1 - M4SE1)	S14.42332	S14.42332	1
	SAE thd. port (SAE drain) (M4E1 - M4SE1) <i>Filettature SAE (drenaggio SAE) (M4E1 - M4SE1)</i>	SAE Gewinde (SAE Leckölanschluß) (M4E1 - M4SE1) <i>Rosca SAE (drenaje SAE) (M4E1 - M4SE1)</i>	Orifices taraudés SAE (drain SAE) (M4E1 - M4SE1)	S14.42333	S14.42333	1
Notes						

## Model Code

Model number :

Series external drain \_\_\_\_\_

Series internal drain \_\_\_\_\_

Torque (Nm/bar) \_\_\_\_\_

153 = 2,52

185 = 3,05

214 = 3,53

Type of shaft \_\_\_\_\_

1 = keyed (SAE C)

3 = splined (SAE C)

Direction of rotation \_\_\_\_\_

N = bi-directional

Porting combination \_\_\_\_\_

00 = standard

Design letter \_\_\_\_\_

Seal class \_\_\_\_\_

5 = S5

Mounting w/connection variables \_\_\_\_\_

01 = SAE threaded port

SAE drain

02 = SAE 4 bolts flange

UNC threaded - SAE drain

04 = SAE 4 bolts flange

UNC threaded - BSPP drain

Modifications \_\_\_\_\_

## Typenschlüssel

Typenbezeichnung :

Baureihe externer Leckölanschluß \_\_\_\_\_

Baureihe interner Leckölanschluß \_\_\_\_\_

Drehmoment (Nm/bar) \_\_\_\_\_

153 = 2,52

185 = 3,05

214 = 3,53

Art der Welle \_\_\_\_\_

1 = Paßfederwelle (SAE C)

3 = Vielkeilwelle (SAE C)

Drehrichtung \_\_\_\_\_

N = Rechts und Linkslauf

Lage der Anschlüsse \_\_\_\_\_

00 = standard

Ausführungsbuchstabe \_\_\_\_\_

Dichtungsklasse \_\_\_\_\_

5 = S5

Gehäuse-Anschlußgröße \_\_\_\_\_

01 = SAE-Gewinde

Leckölanschluß SAE

02 = 4 Loch-Flansch SAE

UNC-Gewinde - Leckölanschluß SAE

04 = 4 Loch-Flansch SAE

UNC-Gewinde - R-Leckölanschluß

Modifikationen \_\_\_\_\_

## Designation - type

Numéro du modèle :

M4\*E1 : 214 : 1 N 00 : B 5 02 ::

Série drain externe \_\_\_\_\_

Série drain interne \_\_\_\_\_

Couple (Nm/bar) \_\_\_\_\_

153 = 2,52

185 = 3,05

214 = 3,53

Type d'arbre \_\_\_\_\_

1 = à clavette (SAE C)

3 = à cannelures (SAE C)

Sens de rotation \_\_\_\_\_

N = Bi-directionnel

Combinaison des orifices \_\_\_\_\_

00 = standard

Conception \_\_\_\_\_

Classe de joint \_\_\_\_\_

5 = S5

Option sur orifices \_\_\_\_\_

01 = taraudage SAE

drain SAE

02 = bride SAE 4 trous

taraudage UNC - drain SAE

04 = bride SAE 4 trous

taraudage UNC - drain BSPP

Modifications \_\_\_\_\_

## Designazione

## Clave de designación

Sigla :

Referencia modelo :

M4\*E1 : 214 : 1 N 00 : B 5 02 ::

Serie drenaggio esterno \_\_\_\_\_

Serie drenaje externo \_\_\_\_\_

Serie drenaggio interno \_\_\_\_\_

Serie drenaje interno \_\_\_\_\_

Coppia (Nm/bar) \_\_\_\_\_

Aro volumetrico (Nm/bar) \_\_\_\_\_

153 = 2,52

153 = 2,52

185 = 3,05

185 = 3,05

214 = 3,53

214 = 3,53

Tipo di albero \_\_\_\_\_

Tipo de eje \_\_\_\_\_

1 = a chiavetta (SAE C)

1 = chaveteado (SAE C)

3 = scanalato (SAE C)

3 = estriado (SAE C)

Senso di rotazione \_\_\_\_\_

Sentido de giro \_\_\_\_\_

N = bidirezionale

N = bi-direccional

Orientamento delle bocche \_\_\_\_\_

Posición de bocas \_\_\_\_\_

00 = standard

00 = estándar

Disegno \_\_\_\_\_

Letra de diseño \_\_\_\_\_

Tipo di guarnizioni \_\_\_\_\_

Clase de juntas \_\_\_\_\_

5 = S5

5 = S5

Dimensioni delle bocche \_\_\_\_\_

Opciones de las bocas \_\_\_\_\_

01 = filettature SAE

01 = rosca SAE

drenaggio SAE

drenaje SAE

02 = flange SAE 4 fori - filettature UNC

02 = SAE 4 agujeros - rosca UNC

drenaggio SAE

drenaje SAE

04 = flange SAE 4 fori - filettature UNC

04 = SAE 4 agujeros - rosca UNC

drenaggio BSP

drenaje BSP

Modifiche \_\_\_\_\_

Modificaciones \_\_\_\_\_