

# MODEL CODE BREAKDOWN

TA 1515 \* - I \*\* - 2525 - \* \* - \* \* - \* \* \* \* 12 L

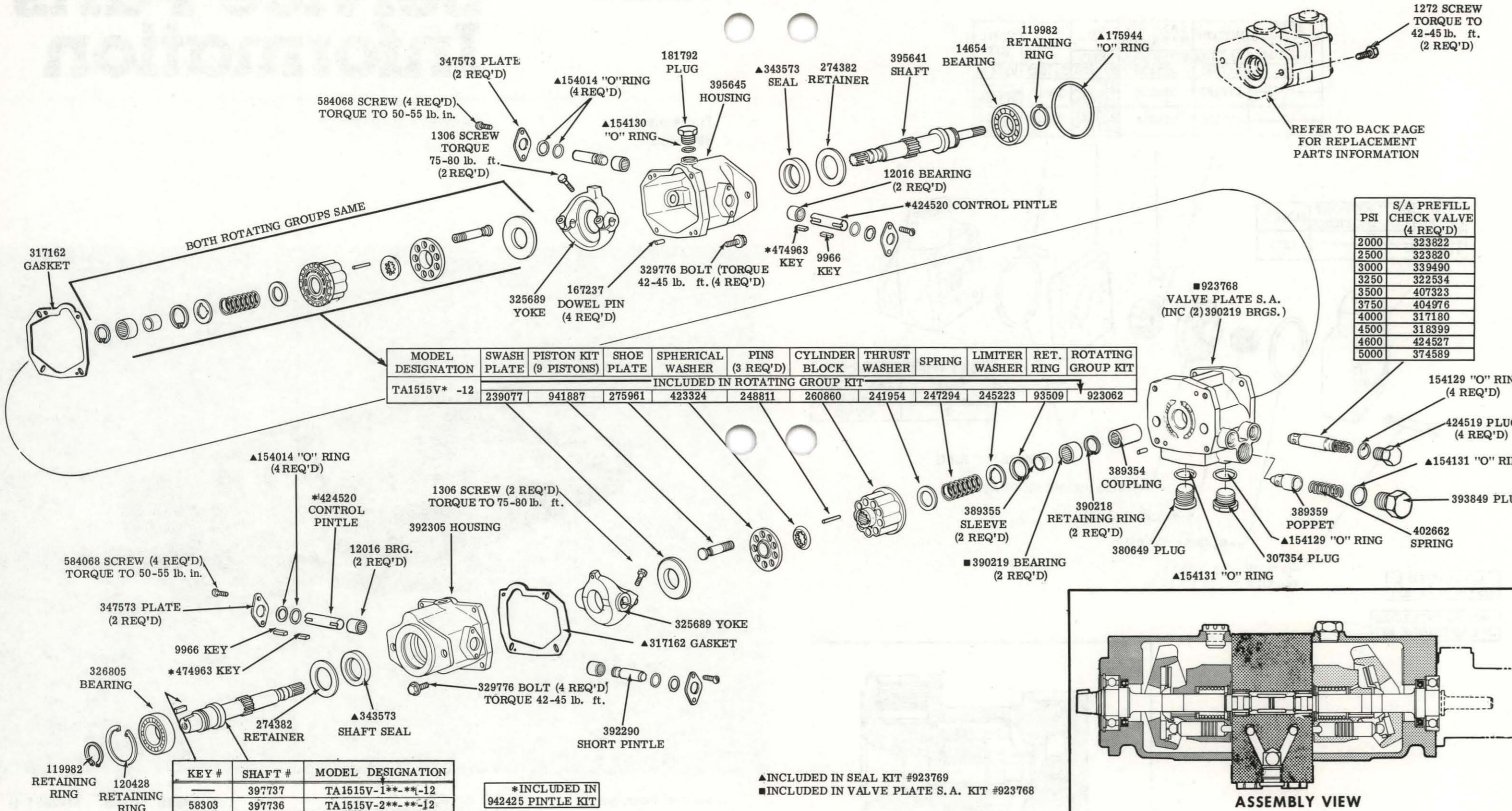

MODEL DESIGNATION	SWASH PLATE	PISTON KIT (9 PISTONS)	SHOE PLATE	SPHERICAL WASHER	PINS (3 REQ'D)	CYLINDER BLOCK	THRUST WASHER	SPRING	LIMITER WASHER	RET. RING	ROTATING GROUP KIT
TA1515V* -12	239077	941887	275961	423324	248811	260860	241954	247294	245223	93509	923062

**INCLUDED IN ROTATING GROUP KIT**

KEY #	SHAFT #	MODEL DESIGNATION
---	397737	TA1515V-1**-* *-12
58303	397736	TA1515V-2**-* *-12

\*INCLUDED IN 942425 PINTLE KIT

▲INCLUDED IN SEAL KIT #923769  
■INCLUDED IN VALVE PLATE S.A. KIT #923768

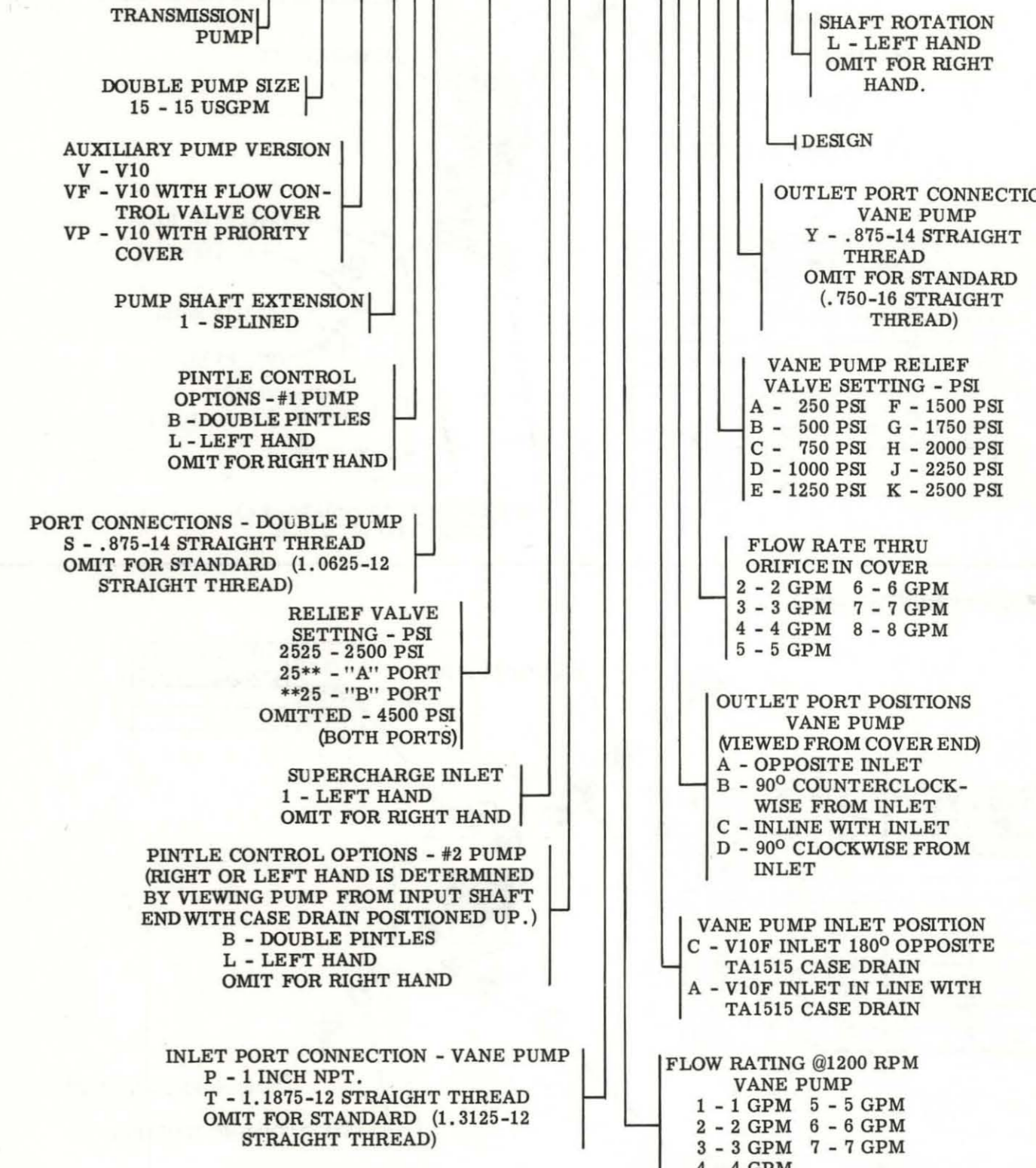

For satisfactory service life of these components, use full flow filtration to provide fluid which meets ISO cleanliness code 16/13 or cleaner. Selections from Vickers OFP, OFR, and OFRS series are recommended.



AV10P-\*\*\*K-\*\*10(L)

RING CAPACITY	SCREW (4 REQ'D) TORQUE 40 ± 5 lb. ft.
1, 2, 3	432509
4, 5	295344
6, 7	432511

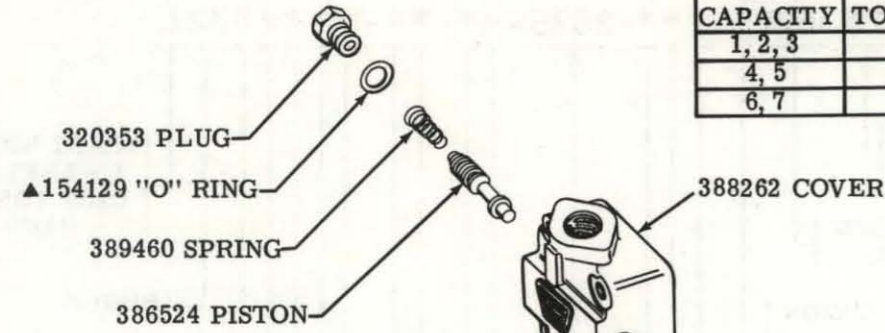

RELIEF VALVE SETTING	PRESSURE SETTING	SPRING
A	250	252886
B	500	2280
C	750	2282
D	1000	2281
E	1250	
F	1500	
G	1750	
H	2000	
J	2250	
K	2500	

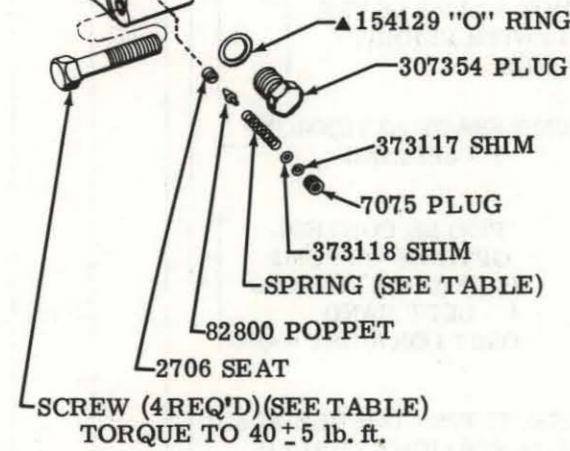

AV10F-\*\*\*(P)(T)-\*\*11(L)

COVER	OUTLET PORT CONNECTIONS
379543	P
372851	T

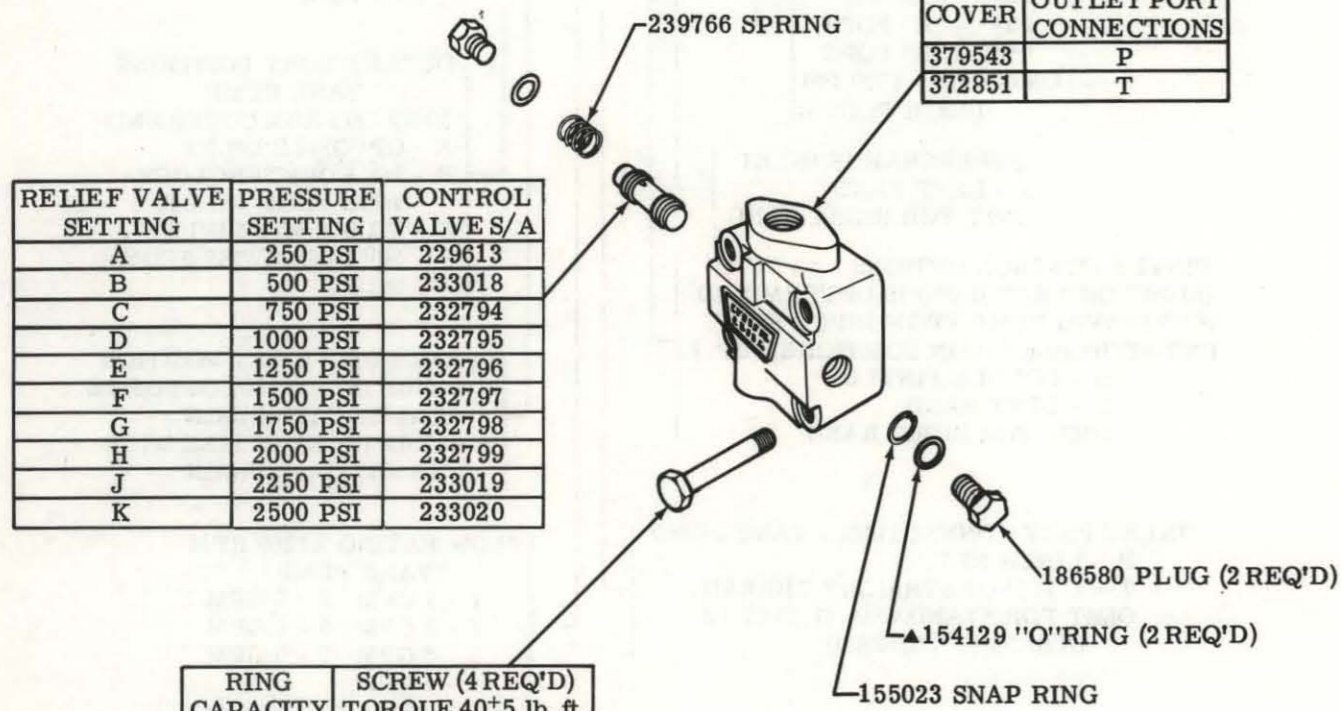

RING CAPACITY	SCREW (4 REQ'D) TORQUE 40 ± 5 lb. ft.
1, 2, 3	432509
4, 5	295344
6, 7	432511

RING CAPACITY USGPM	ROTOR	VANE KIT (12 VANES) INCLUDED IN CART. KIT	RING	PIN	CART. KIT
3	317681	923499	317676	231042	923496
4	417297	923500	317677	39640	923928
5			317678		
6	417212	923501	355641	16662	923912
7			331813		

STD COVER	OUTLET PORT CONNECTIONS	SCREW
372863	P	1278
372865	S	

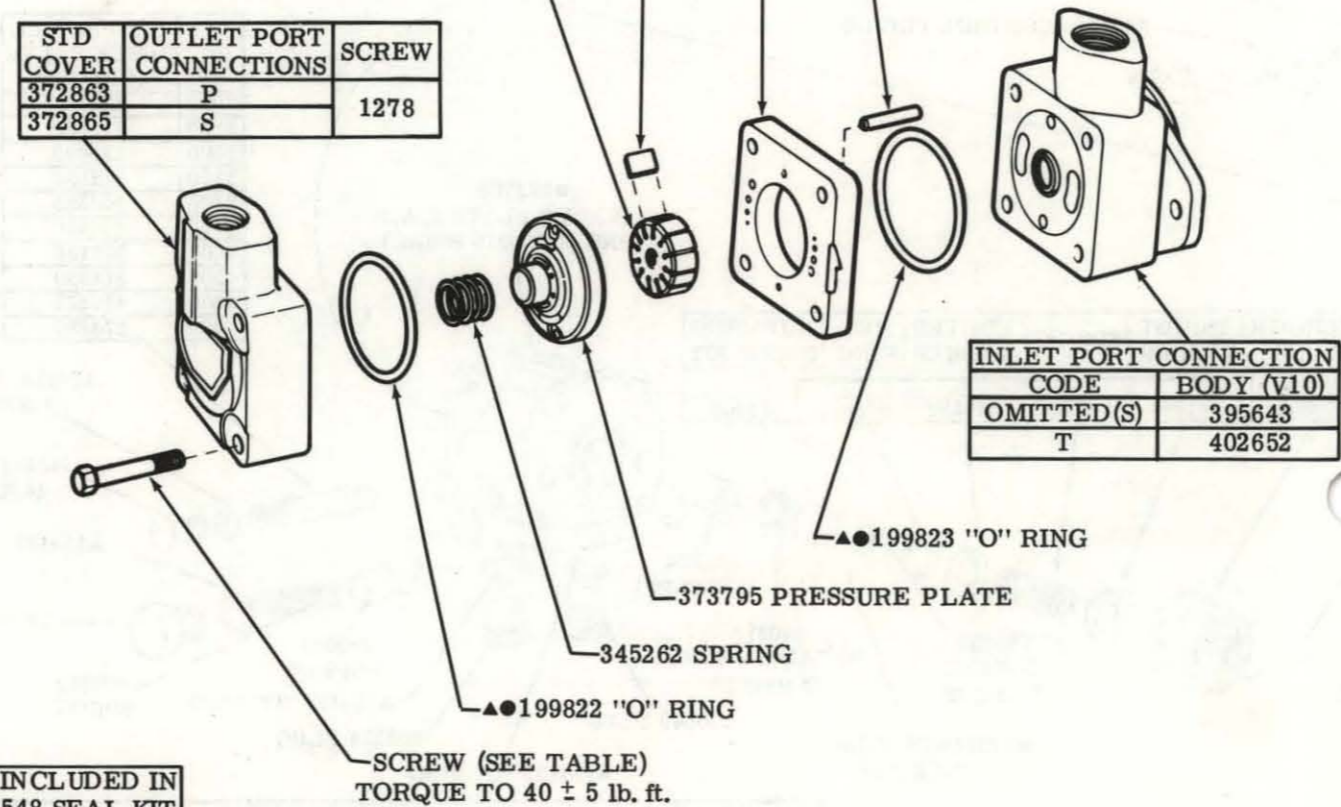

▲ INCLUDED IN 923548 SEAL KIT

● ALSO INCLUDED IN CARTRIDGE KIT

SCREW (SEE TABLE) TORQUE TO 40 ± 5 lb. ft.

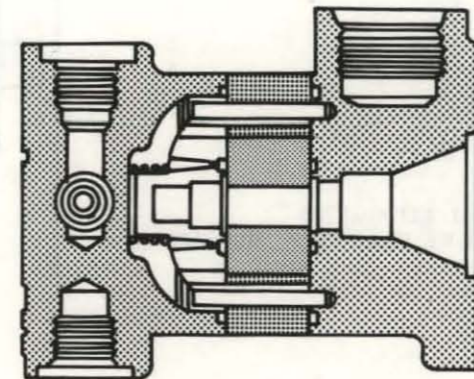

**VICKERS**  
A TRIMOVA COMPANY

# Service Parts Information

Transmission Package

TA1515V-10/12 Design

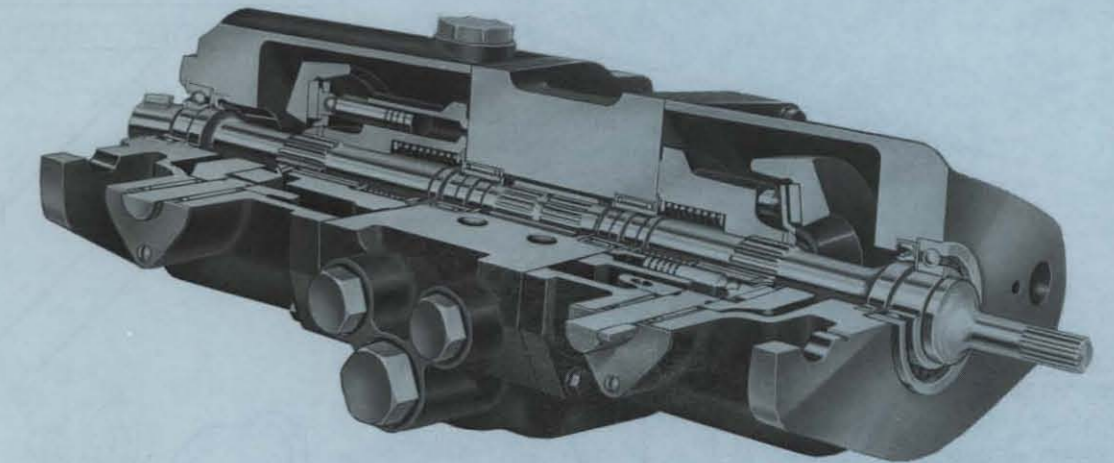

Vickers, Incorporated

P.O. Box 302  
Troy, Michigan 48007-0302

Revised 1-1-88 M-2851-S