

Service Parts Information

NOTE
TO CONVERT FLANGE MODEL
TO FOOT BRACKET MODEL,
ORDER FB-B-10 (ASS'Y 422583)

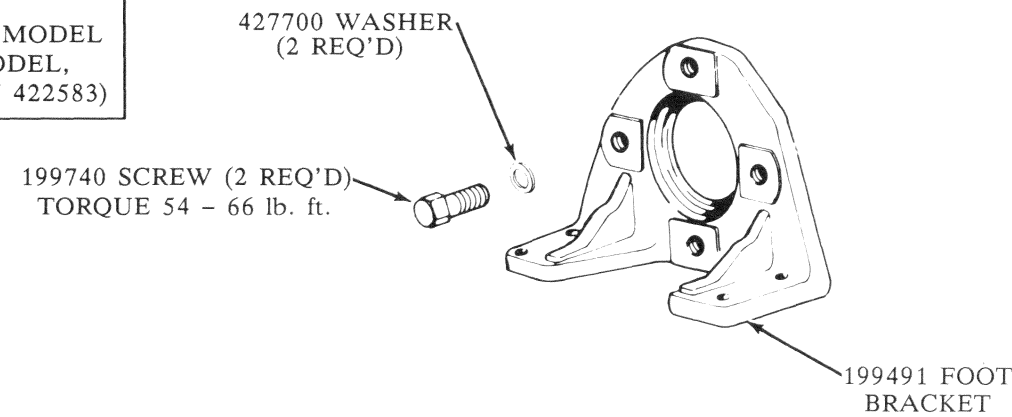

**Variable Displacement
Piston Pumps With
Pressure Compensator**

PVE19/21-**-**-20-C***-1*
PVE19/21-**-**-30-C***-1*

MODEL CODE BREAKDOWN

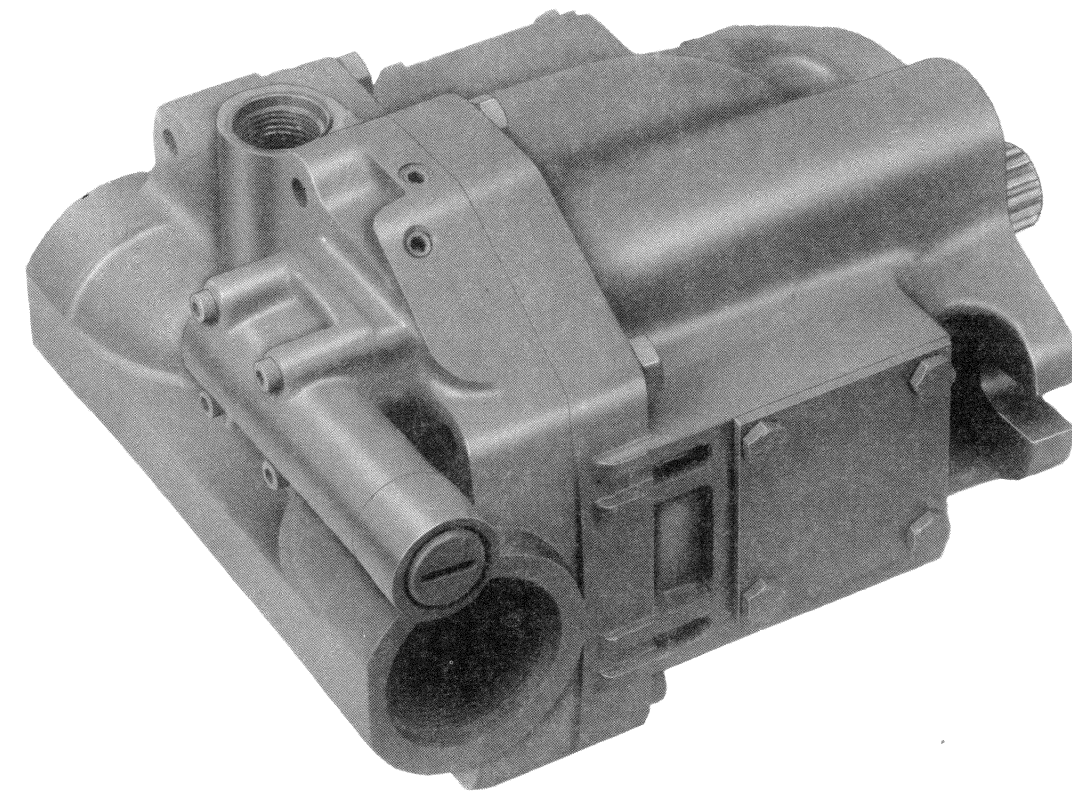
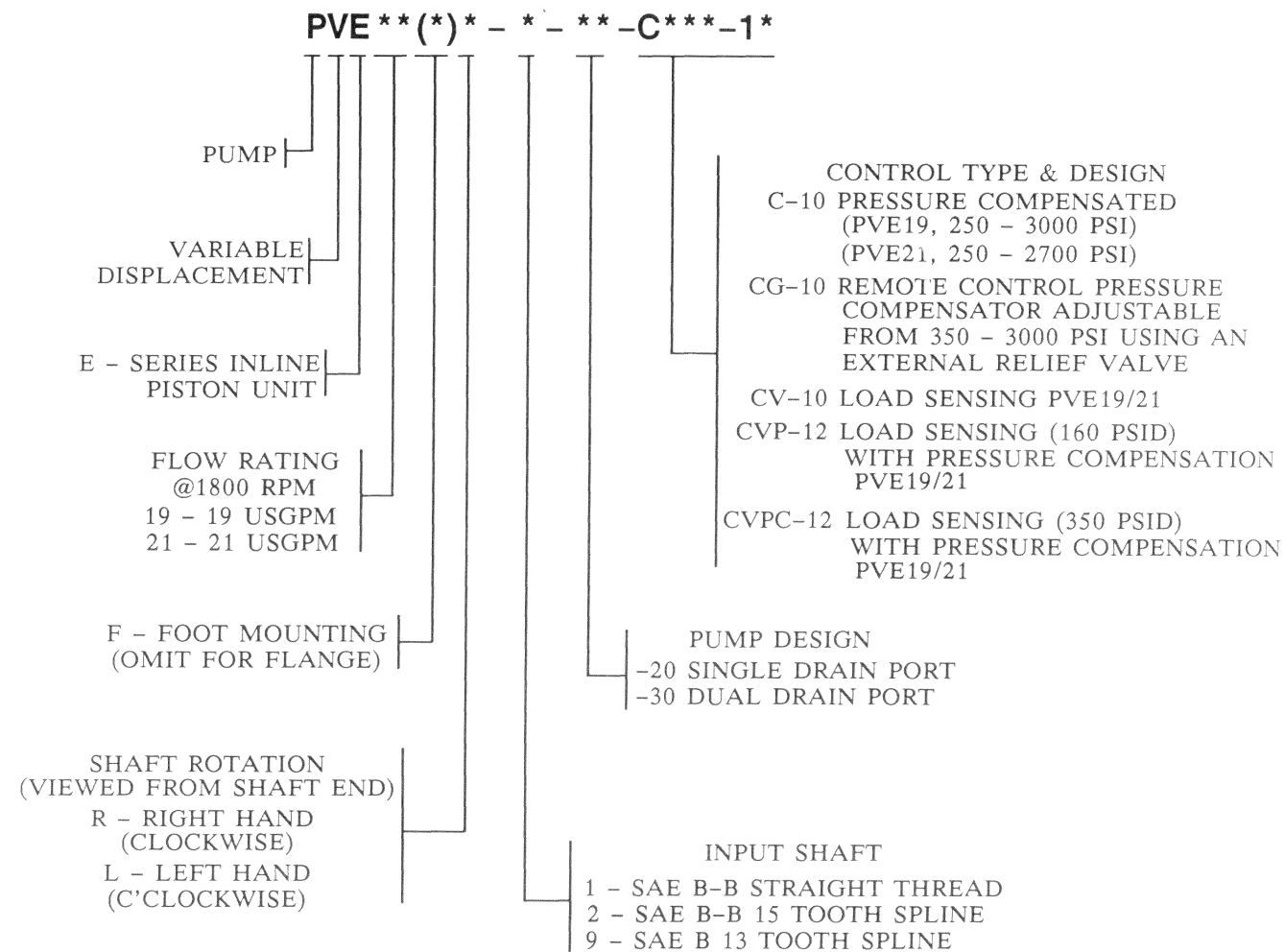

Vickers, Incorporated

P.O. Box 302
Troy, Michigan 48007-0302

Revised 10-1-88

M-2841-S

To insure sustained efficiency and maximum trouble free life of this precision equipment, initial and continuous full flow filtration of the fluid medium is essential. Select and apply filters from the Vickers OFP, OFR, and OFRS series, which are available in 3, 10, and 25 micrometre filtration ratings.

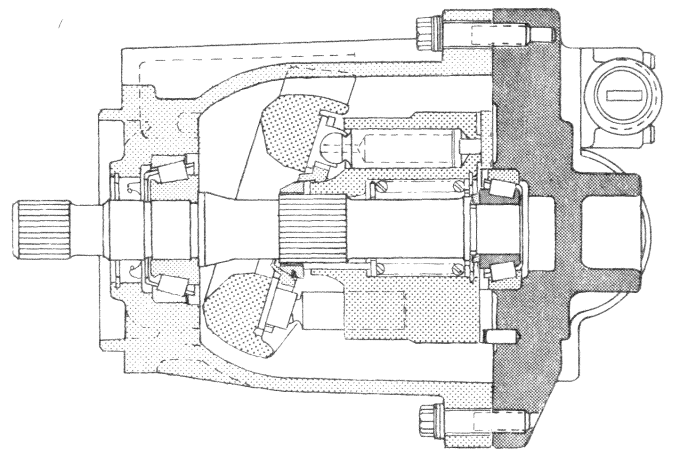

NOTE
 THE "CVP" COMPENSATOR MAY BE OBTAINED AS A COMPLETE FACTORY TESTED UNIT BY ORDERING PART NUMBER SHOWN IN TABLE BELOW.

C, CG & CV COMPENSATOR

(SHOWN FOR RIGHT HAND SHAFT ROTATION. ROTATE 180° FOR LEFT HAND SHAFT ROTATION)

CVP(C) COMPENSATOR

SHOWN FOR RIGHT HAND SHAFT ROTATION, ROTATE 180° FOR LEFT HAND SHAFT ROTATION. SEE TABLE FOR CVP S/A PART NUMBERS.

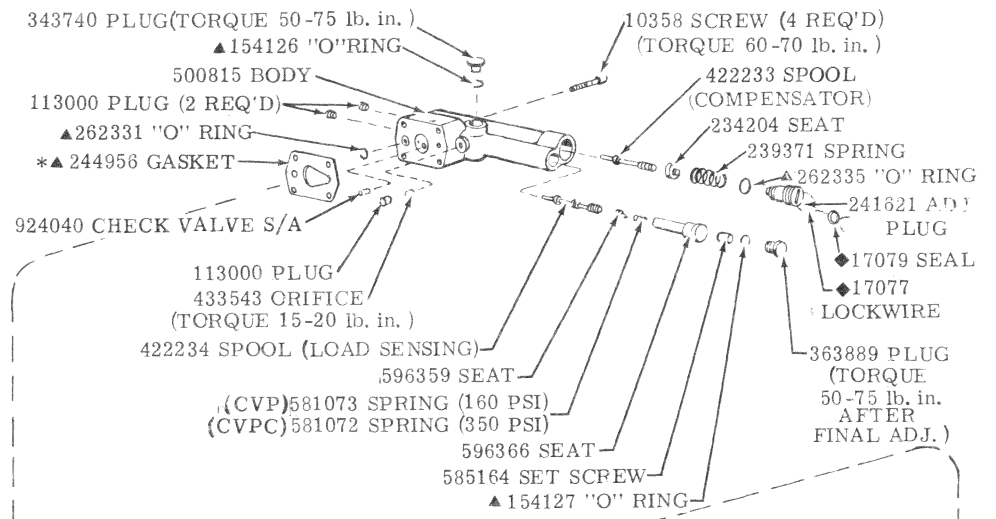

ASSEMBLY NOTE
 ADJUST COMPENSATOR THEN DRILL THRU WITH A #1089 DRILL. INSERT LOCKWIRE THRU SEAL; THEN COMPRESS SEAL WITH A SUITABLE TOOL.

INCLUDED IN	
▲ SEAL KIT PISTON PUMP	923989
BEARING SPACER KIT	942401
SHIM KIT	923938

■ INCLUDED IN ROTATING GROUP S/A

MODEL	BODY	SPOOL	SPRING	"O" RING	BU RING	PLUG	COMPENSATOR S/A KIT
PVE**-"C"-10	241588	241717	239371			241621	941700
PVE**-"CG"-10	412890	296234		▲ 262335	▲ 197573	412940	942480
PVE**-"CV"-10		278711	417649				942441

***CAUTION**
 POSITION GASKET WITH SMALL END OF TEARDROP HOLE POINTING IN DIRECTION OF COMPENSATOR ADJUSTING PLUG.

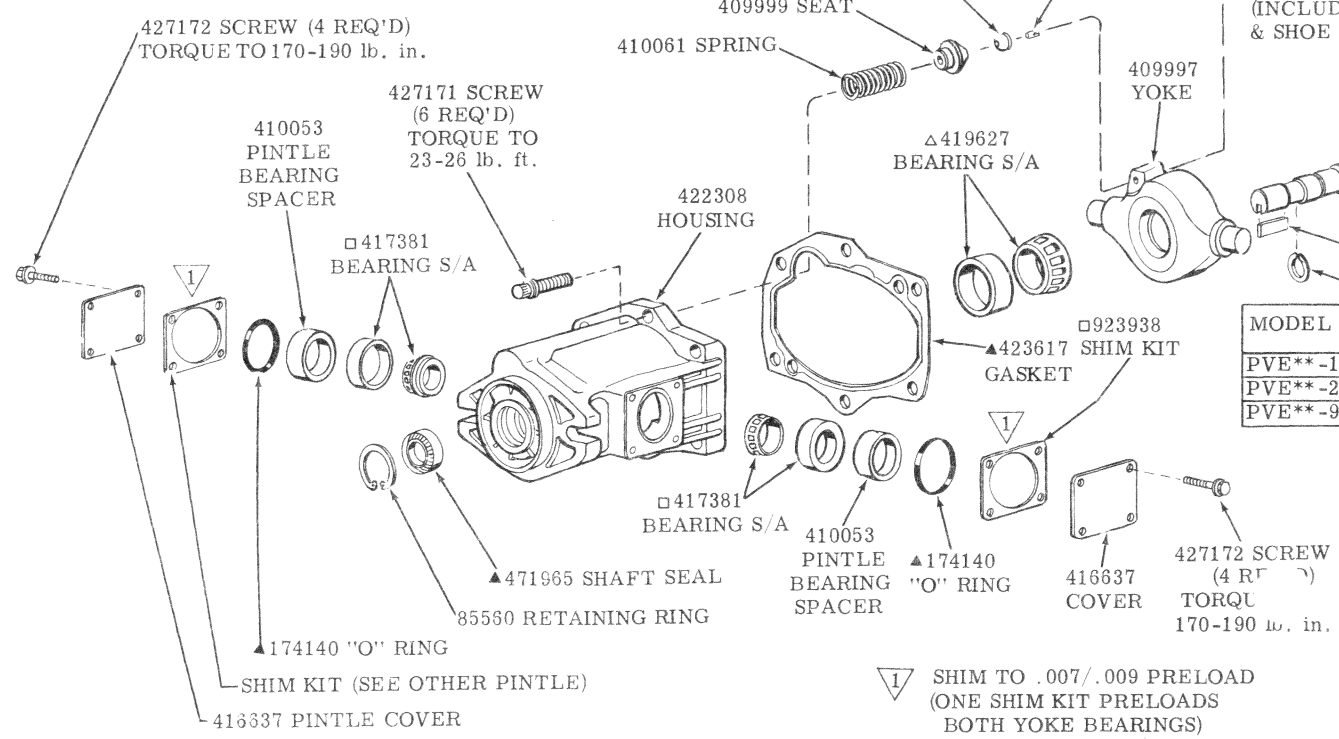

MODEL	RETAINING RING	KEY	SHAFT	TYPE
PVE**-1	112531	58303	428883	KEYED
PVE**-2			423415	SPLINE
PVE**-9			424544	

MODEL	CVP-12 S/A	CVPC-12 S/A
PVE19	924061	924062
PVE21	924063	924064

MODEL	ROTATION VIEWED FROM SHAFT END	-20 VALVE BLOCK	-30 VALVE BLOCK	WAFER PLATE	■ CYL. BLOCK	PISTON SHOE S/A INCL. 9 PISTON SHOE S/A	■ ROT. GROUP
PVE19-R	C/WISE	423337	429729	425412			
PVE19-L	CC/WISE	423329	435281	425415	426454	923939	923948
PVE21-R	C/WISE	423337	429729	425413	418215	923946	923947
PVE21-L	CC/WISE	423329	435281	425416			

● INCLUDED IN 923960 COMPENSATOR PISTON & ROD S/A KIT.

□ INCLUDED IN 923987 YOKE BEARING KIT

△ INCLUDED IN 923988 SHAFT BEARING KIT

1 SHIM TO .007/.009 PRELOAD (ONE SHIM KIT PRELOADS BOTH YOKE BEARINGS)
 2 SELECT SPACER TO PROVIDE .001/.003 PRELOAD.