

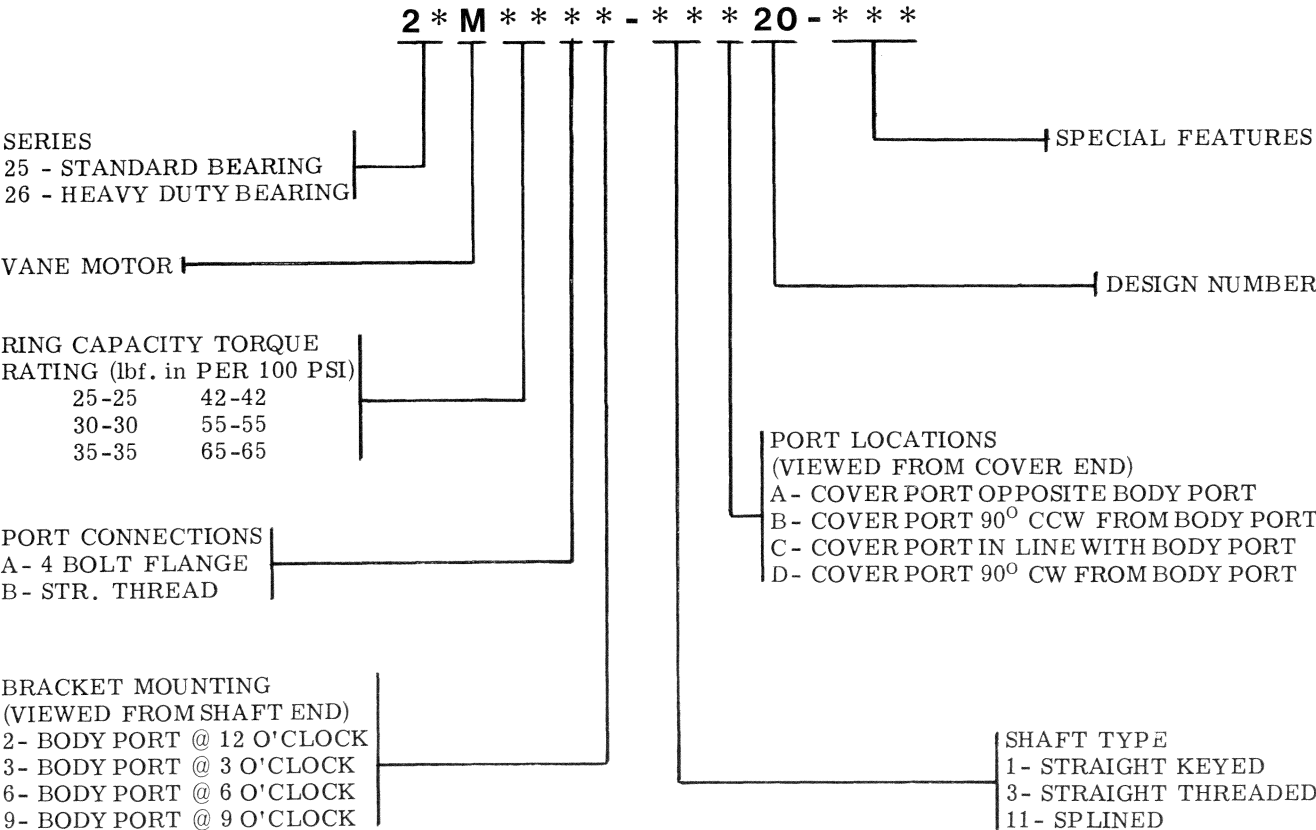

MODEL CODE BREAKDOWN



Vane Motors

25M & 26M Series -20 Design

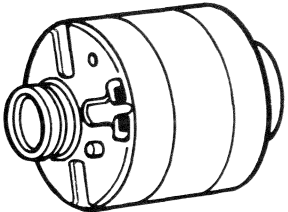
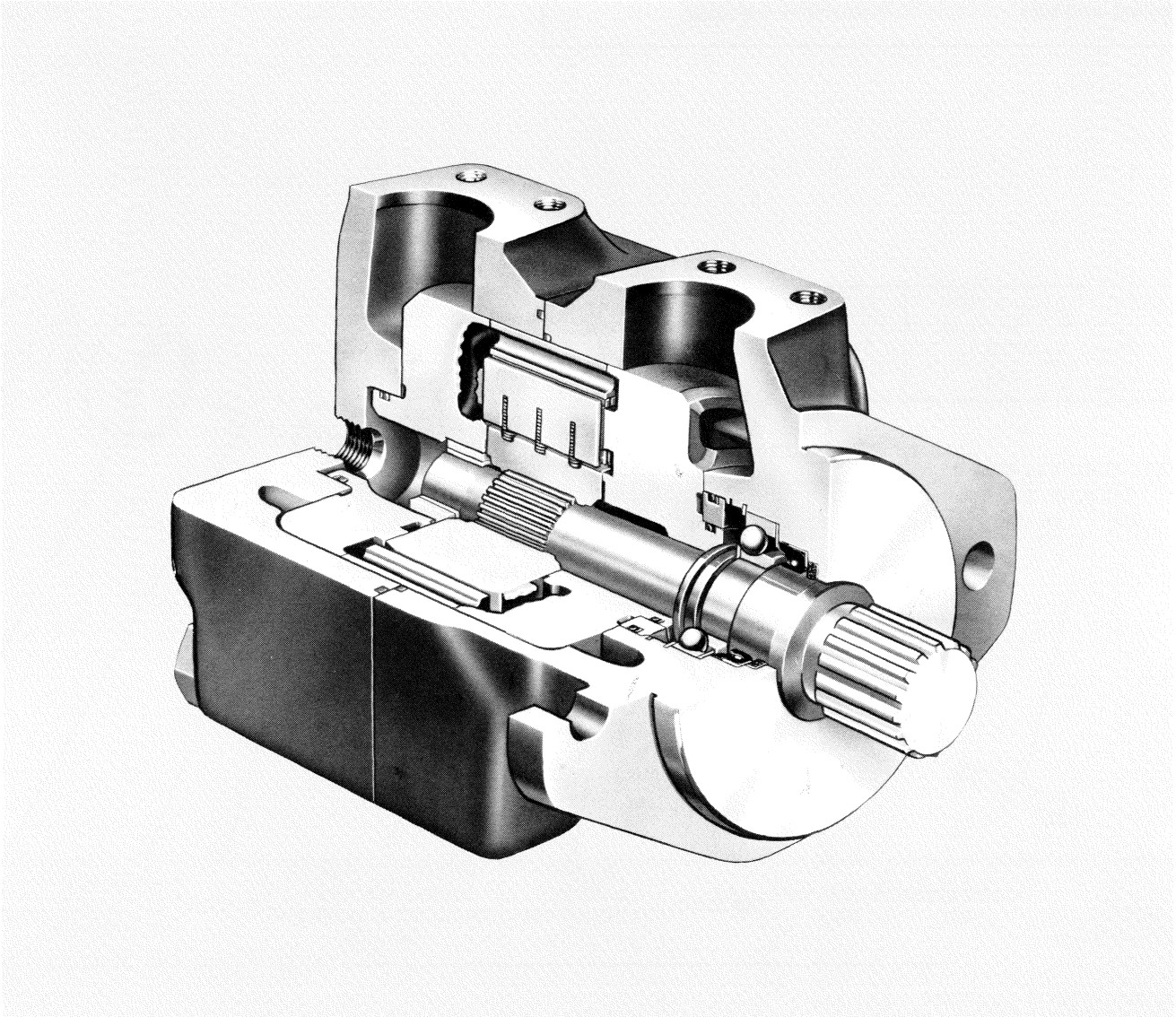

WHEN ORDERING SPARE CARTRIDGE PARTS, IT IS RECOMMENDED THEY BE OBTAINED IN CARTRIDGE KITS. KITS ARE ASSEMBLED AND TESTED BY VICKERS BEFORE SHIPMENT.

For satisfactory service life of these components, use full flow filtration to provide fluid which meets ISO cleanliness code 18/15 or cleaner. Selections from Vickers OFP, OFR, and OFRS series are recommended.

Litho in U.S.A.

Vickers Incorporated
 A TRINOVA Company
 5445 Corporate Drive
 P.O. Box 302
 Troy, Michigan 48007-0302
 U.S.A.

Revised 12-1-87

M-2741-S

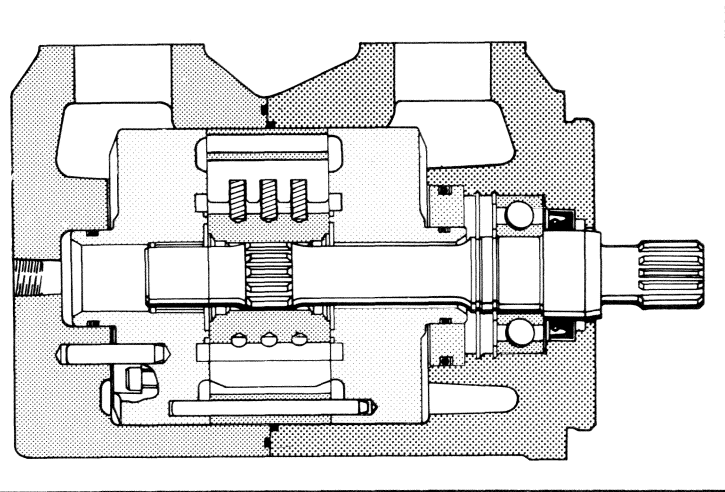

MODEL DESIGNATION	BODY
2*M * A - **20	312139
2*M * B - **20	317282

MODEL DESIGNATION	BEARING
25M**-**20	1705
26M**-**20	232750

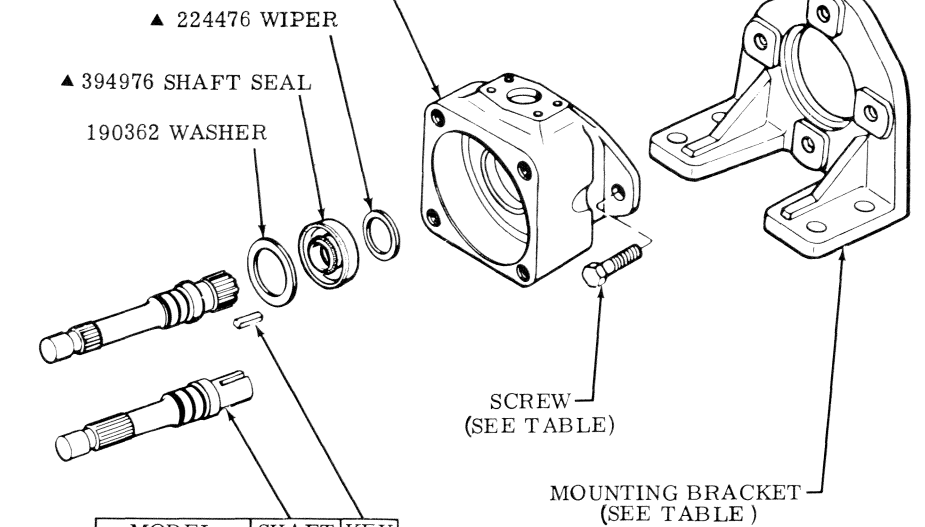

MODEL	SHAFT	KEY
2*M**-1*20	312153	9955
2*M**-2*20	431243	
2*M**-11*20	312154	

SCREW (2 REQ'D)	MOUNTING BRACKET (INCL. SCREWS)	MODEL
199740	FB-B-10	2*M**()-**20

(VIEWED FROM SHAFT END)
 2 = BODY PORT @ 12 O'CLOCK POSITION
 3 = BODY PORT @ 3 O'CLOCK POSITION
 6 = BODY PORT @ 6 O'CLOCK POSITION
 9 = BODY PORT @ 9 O'CLOCK POSITION

▲ INCLUDED IN SEAL KIT 923157

MODEL DESIGNATION	COVER
2*M * A - **20	312140
2*M * B - **20	317283

11165 SCREW (4 REQ'D)
TORQUE TO 100 ± 5 lb. ft.

312152 HUB ADAPTER

120128 RETAINING RING
191400 LOCK RING

MODEL DESIGNATION	CARTRIDGE KIT	BACK-UP RING	"O" RING	SCREW (2 REQ'D) TORQUE TO 2-4 lbf. ft.	PRESSURE PLATE SUB-ASSEMBLY (INCLUDING BUSHING AND PINS)	ROTOR	VANE KIT 10 VANES 30 SPRINGS	PIN (2 REQ'D)	RING	PRESSURE PLATE	"O" RING	BACK-UP RING	O" RING	BACK-UP RING	"O" RING	SEAL
THESE PARTS ARE SERVICED IN CARTRIDGE KIT																
2*M 42**-**20	923160								313426							
2*M 55**-**20	923161	▲271699	▲187000	276618	312145	312155	923158	158465	313427	312143	▲187000	▲271699	▲154080	▲271791	▲312388	▲278708
2*M 65**-**20	923162								313428							