

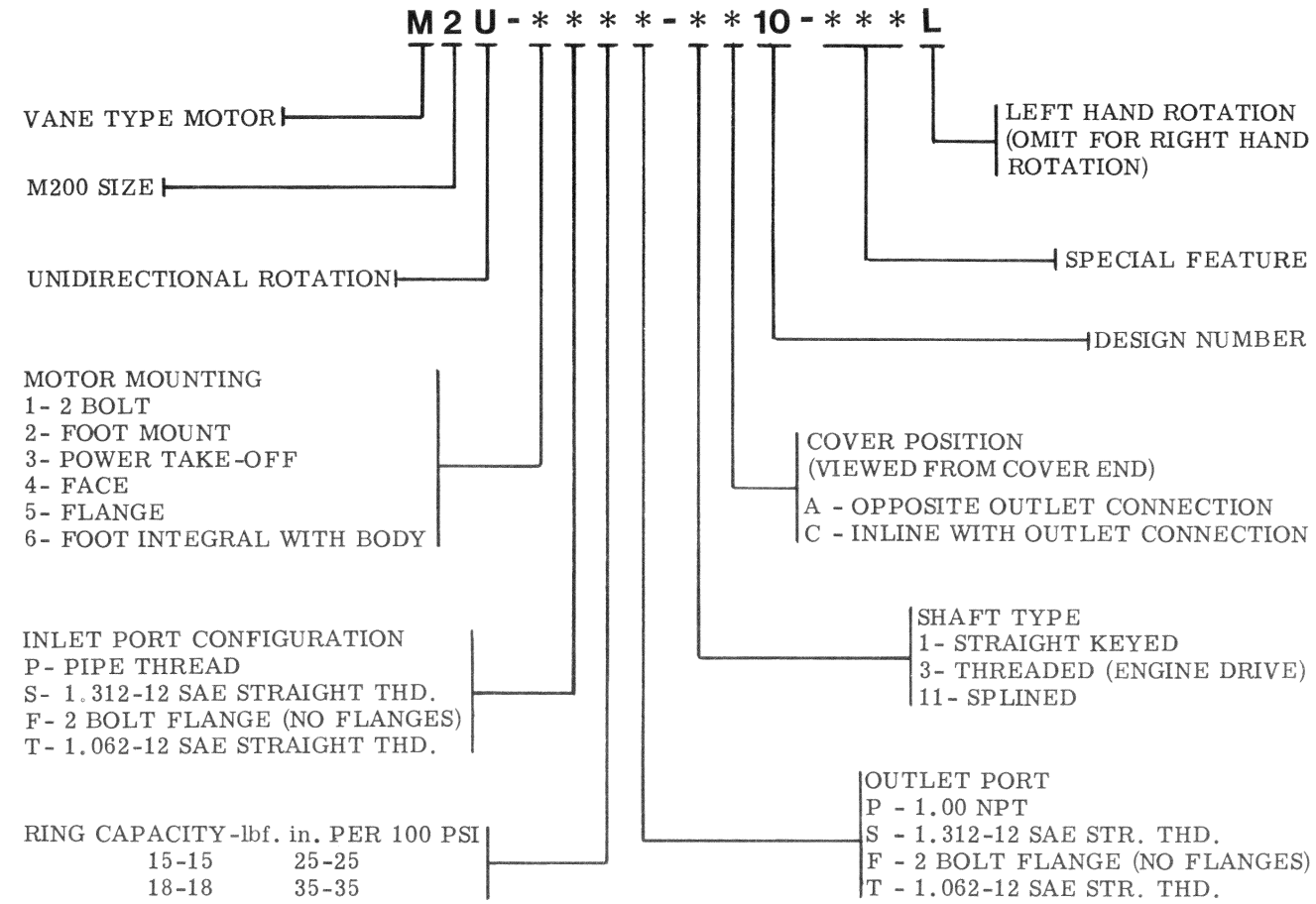

### MODEL CODE BREAKDOWN



## Vane Motors

### M2U Series -10 Design

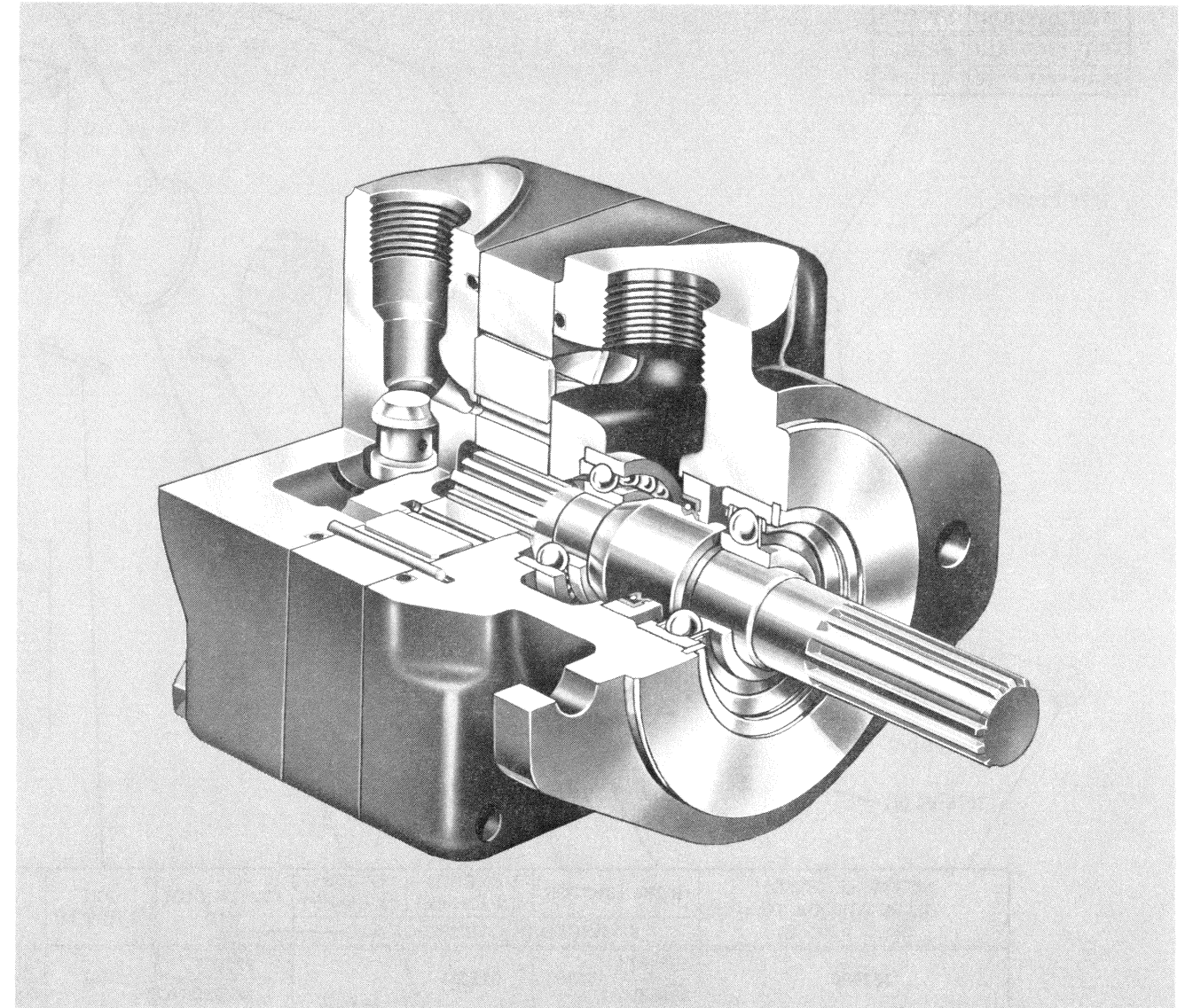

For satisfactory service life of these components, use full flow filtration to provide fluid which meets ISO cleanliness code 18/15 or cleaner. Selections from Vickers OFP, OFR, and OFRS series are recommended.

Litho in U.S.A.

Vickers Incorporated  
 A TRINOVA Company  
 5445 Corporate Drive  
 P. O. Box 302  
 Troy, Michigan 48007-0302  
 U.S.A.

MODEL DESIGNATION	COVER
M2U-*S**-**10	285436
M2U-*T**-**10	327624

MODEL DESIGNATION	SEAL KIT	"O" RING (2 REQ'D) SERVICED IN SEAL KIT	SEAL	RETAINING RING	SHAFT	KEY	NUT
M2U - **** - 1 * 10	922732	154090	229236	—	116644	5881	—
M2U - **** - 3 * 10	922733		229235	98653	120037	1615	132260
M2U - **** - 11 * 10	922732		229236	—	133178	—	—

7076 PLUG

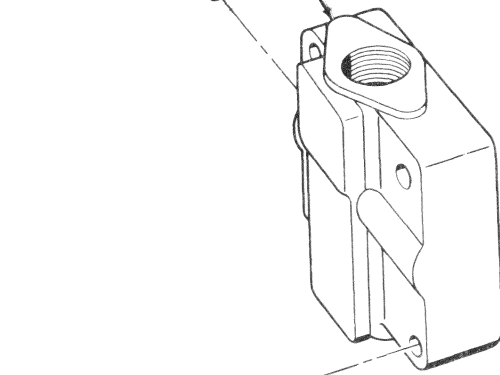

280719 POPPET

25896 SPRING

7078 PLUG

SCREW (4 REQ'D) OIL & TORQUE TO 70 ± 5 lbf. ft.	RING	ROTOR	VANE KIT (12 VANES)	"O" RING (2 REQ'D)	CARTRIDGE KIT	PIN (2 REQ'D)	MODEL DESIGNATION
	SERVICED IN CARTRIDGE KIT						
131486	293587	172302	912031	154090	923057	2161	M2U - ** 15 - * ** 10
	288833				922929		M2U - ** 18 - * ** 10
1319	288835	172294	912032		922930	2478	M2U - ** 25 - * ** 10
	288837	215043	922568		922931	16662	M2U - ** 35 - * ** 10

BODY	MODEL DESIGNATION
119375	M2U- 1 ** P - ** 10
162250	M2U- 1 ** S - ** 10
116655	M2U- 1 ** F - ** 10
119986	M2U- 4 ** P - ** 10
286629	M2U- 4 ** S - ** 10

SCREW	SEAL	MOUNTING BRACKET	SCREW	MODEL DESIGNATION
177939 (2 REQ'D)	—	FOOT BKT. FB-A-10 (INCLUDES SCREWS)	—	M2U - 2 *** - ** 10
—	("O" RING) 154084	(FLANGE) 128893	1272-A (2 REQ'D)	M2U - 3 *** - ** 10
—	(GASKET) 2546	(FLANGE) 131966	1070 (6 REQ'D)	M2U - 5 *** - ** 10

109975  
RETAINING RING

98574 BEARING

1703 BEARING

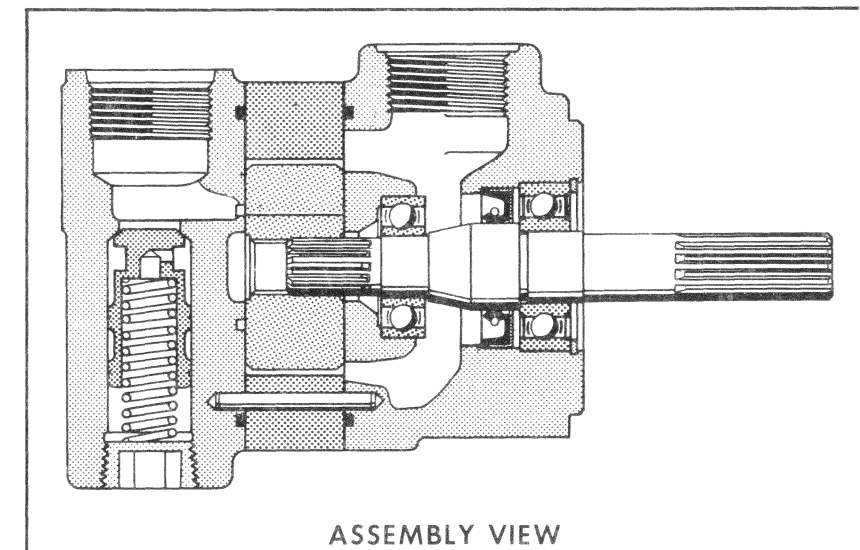

ASSEMBLY VIEW

INCLUDE COMPLETE MODEL NUMBER ON ALL PARTS ORDERS