



MODEL CODE BREAKDOWN

4525 VSH 42 A 12 F *** ** 10 L

1 2 3 4 5 6 7 8 9 10

1 Series
(4525 Double Pump)

2 Intra-Vane Pump
(VSH Series)

3 US GPM Capacity
(Shaft End Pump)
SAE Rating 1200 RPM-100 PSI (7 Bar)
42 - 42 GPM 60 - 60 GPM
50 - 50 GPM

4 SAE Port Connections
Code Inlet Outlet # 1 Outlet # 2
A 4-Bolt Flg. 4-Bolt Flg. 4-Bolt Flg.
E 4-Bolt Flg. 4-Bolt Flg. SAE ST. Thd.

5 US GPM Capacity
(Cover End Pump)
SAE Rating 1200 RPM-100 PSI (7 Bar)
12 - 12 GPM 17 - 17 GPM
14 - 14 GPM 21 - 21 GPM

6 Mounting
F - Foot
Omit - Flange

7 Shaft Type
412 - STR. Key

8 Outlet Port Positions
(Viewed From Cover End Of Pump)

With No. 1 Outlet Opposite Inlet :
AA - No. 2 Outlet - 135° CCW From Inlet
AB - No. 2 Outlet - 45° CCW From Inlet
AC - No. 2 Outlet - 45° CW From Inlet
AD - No. 2 Outlet - 135° CW From Inlet

With No. 1 Outlet 90° CCW From Inlet :
BA - No. 2 Outlet - 135° CCW From Inlet
BB - No. 2 Outlet - 45° CCW From Inlet
BC - No. 2 Outlet - 45° CW From Inlet
BD - No. 2 Outlet - 135° CW From Inlet

With No. 1 Outlet Inline With Inlet :
CA - No. 2 Outlet - 135° CCW From Inlet
CB - No. 2 Outlet - 45° CCW From Inlet
CC - No. 2 Outlet - 45° CW From Inlet
CD - No. 2 Outlet - 135° CW From Inlet

With No. 1 Outlet 90° CW From Inlet :
DA - No. 2 Outlet - 135° CCW From Inlet
DB - No. 2 Outlet - 45° CCW From Inlet
DC - No. 2 Outlet - 45° CW From Inlet
DD - No. 2 Outlet - 135° CW From Inlet

9 Design

10 Shaft Rotation
(Viewed From Shaft End)
L - Left Hand (CCW Rotation)
Omit - Right Hand (CW Rotation)

Double Vane Pump

4525VSH 42 A 12 F 412 ** 10

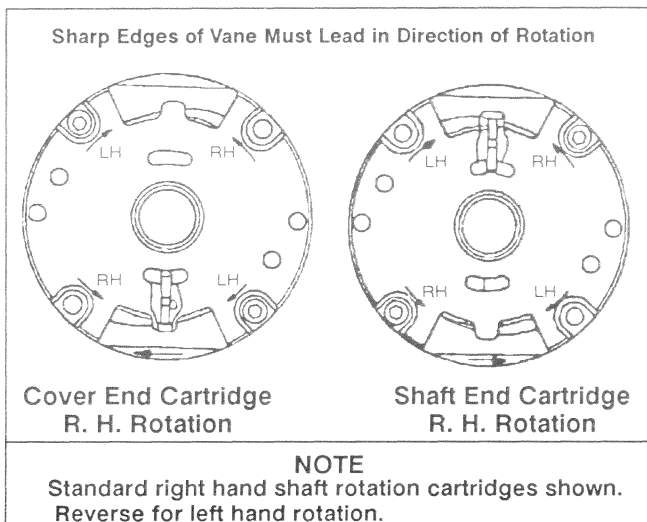
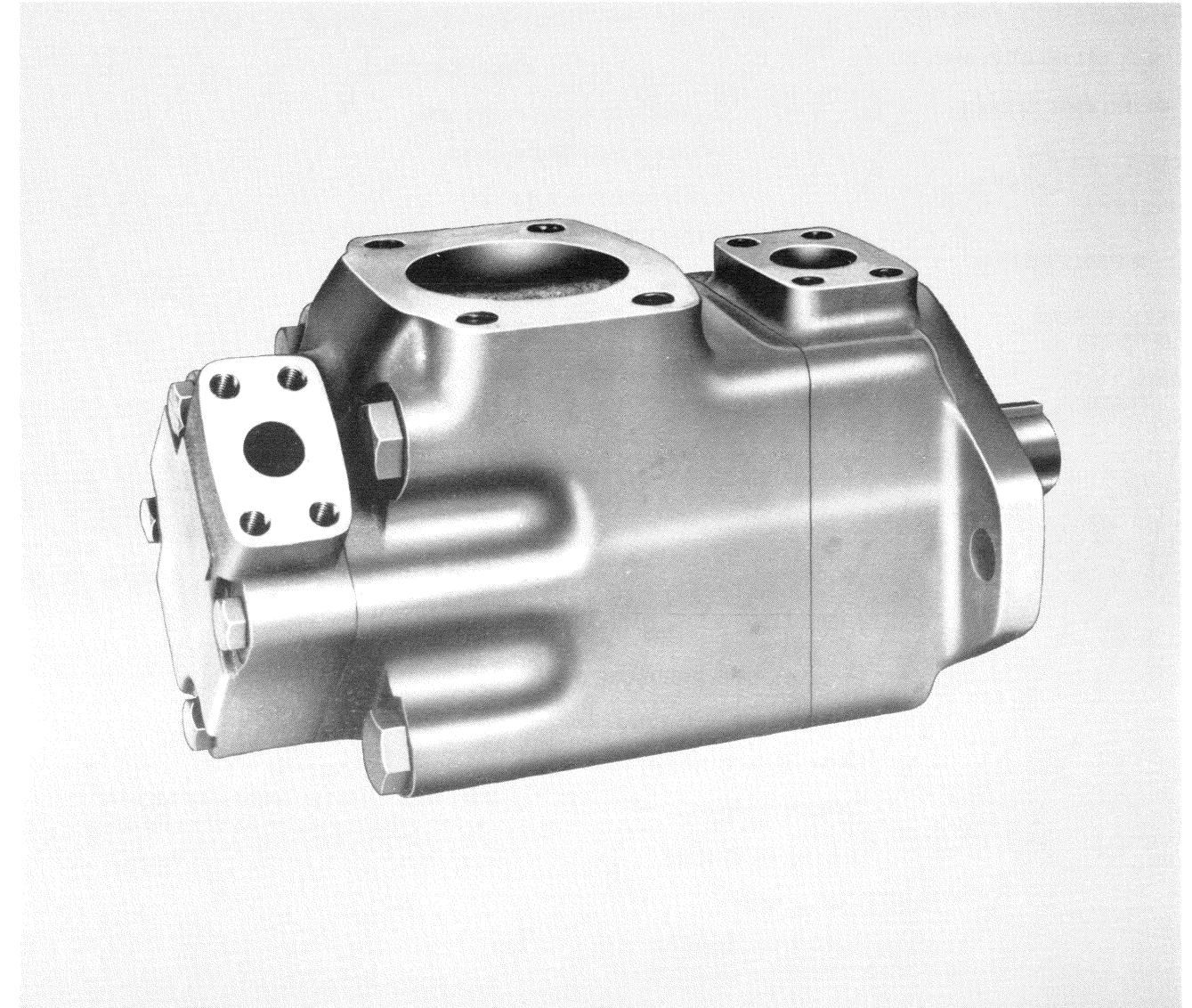

NOTE
To reverse cartridge kit rotation, remove the two screws and reverse the location of the inlet support plate and the outlet support plate. Reinstall the two screws hand tight. Use pump cover to align all sections of the cartridge. Carefully remove the cover and tighten the screws.

When ordering spare cartridge parts, it is recommended they be obtained in cartridge kits. Kits are assembled and tested for either right or left hand rotation. If left hand rotation is required, it should be specified on parts order by adding suffix "L" to cartridge kit number.

For satisfactory service life of these components, use full flow filtration to provide fluid which meets ISO cleanliness code 18/15 or cleaner. Selections from OFP, OFR, and OFRS filter series are recommended.

Vickers Incorporated
A TRINOVA Company
5445 Corporate Drive
P. O. Box 302
Troy, Michigan 48007-0302
U.S.A.

CAPACITY (GPM) COVER END PUMP	● RING	● CARTRIDGE KIT
12	584610	860127
14	584612	860128
17	584614	860129
21	584616	860130

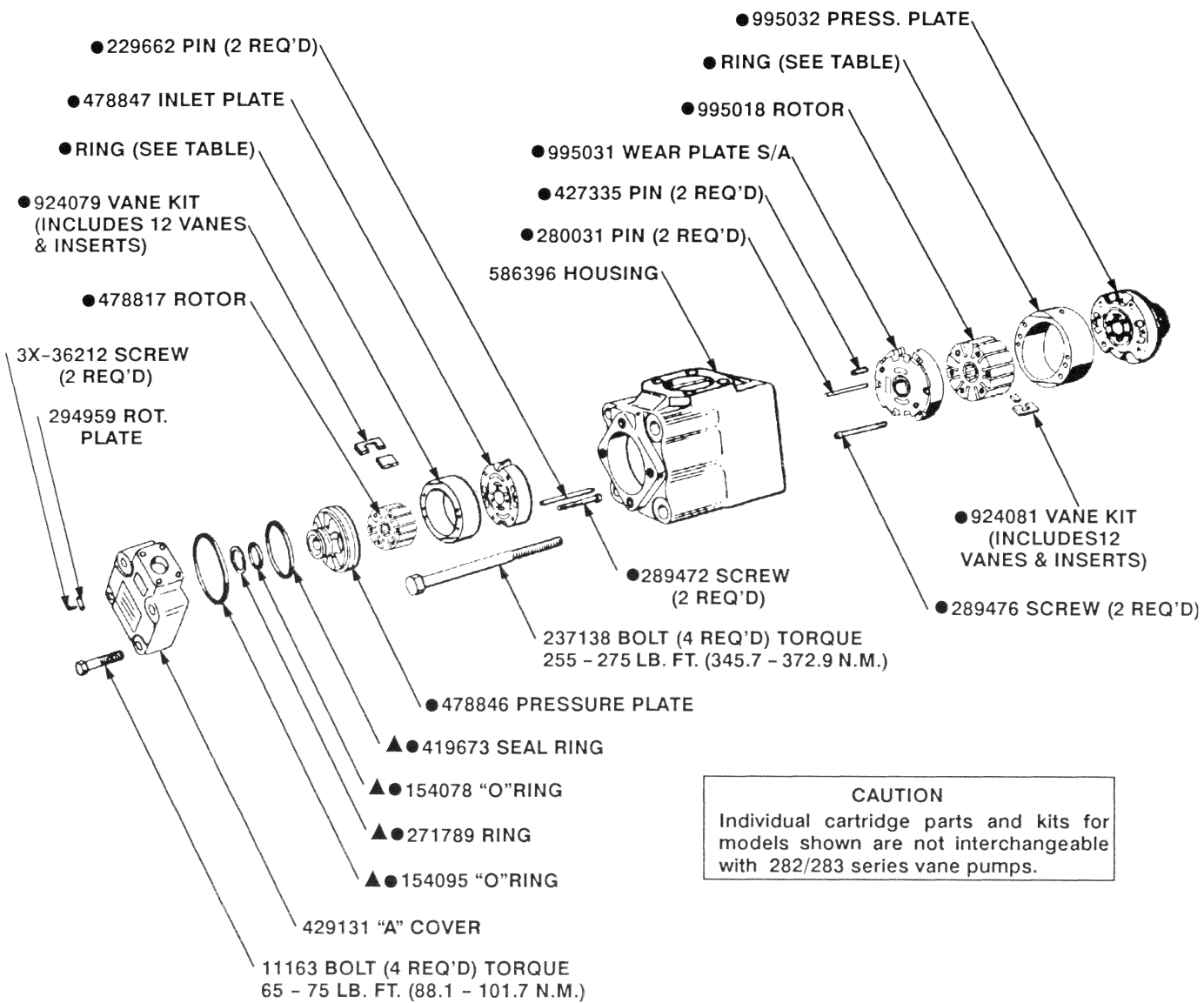

CAUTION
Individual cartridge parts and kits for models shown are not interchangeable with 282/283 series vane pumps.

- INCLUDED IN CARTRIDGE KIT
- ▲ INCLUDED IN SEAL KIT 875839
- ◇ INCLUDED IN FB-C-10/12

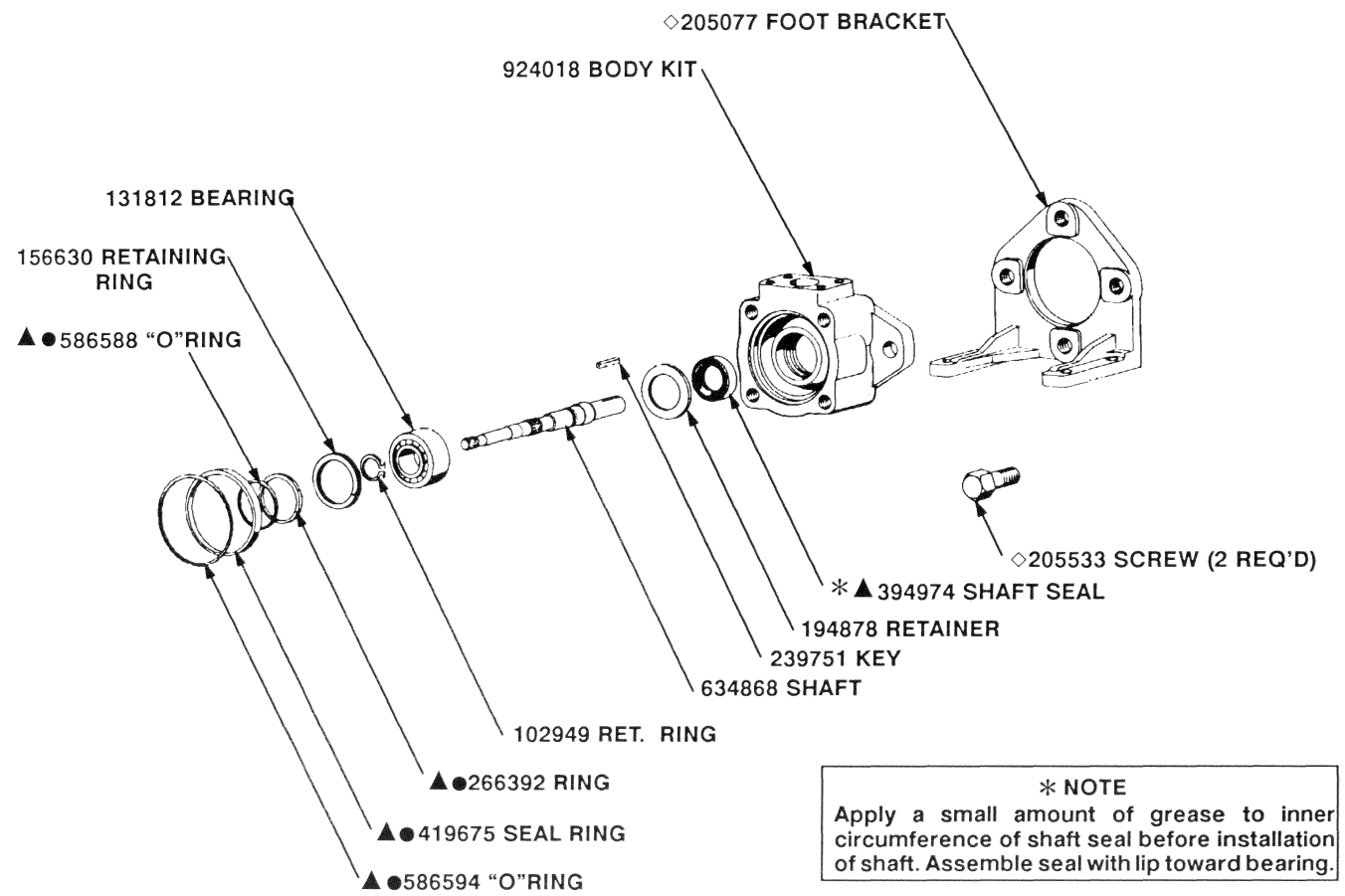

*** NOTE**
Apply a small amount of grease to inner circumference of shaft seal before installation of shaft. Assemble seal with lip toward bearing.

CAPACITY (GPM) SHAFT END PUMP	● RING	● CARTRIDGE KIT
42	581679	995013
50	581680	995014
60	578904	995015

