

Model Code

(F3) D G 4 S 4 ** - 01 * C - (U) * - * - 60 - (LH)

1
2
3
4
5
6
7
8
9
10
11
12
13
14
15

1 Special Seals

Blank - Standard seals
F3 - Special seals

2 Directional Control Valve

3 Manifold or Subplate Mounted

4 Solenoid Operated

5 Sliding Spool

6 Flow Direction

4 - Four way

7 Electrical Accessories

L - Solenoid indicator lights
W - Wiring housing
LW - Wiring housing with indicator lights
WT - Wiring housing with terminal strip

8 Interface

01 - ISO-4401-AC-50-4-A NFPA D05
(1/8 in. nominal size)

9 Spool Types

0, 1, 2, 3, 6, 7, 8, 11, 31 & 33

10 Spool/Spring Arrangement

B - Spring centered solenoid "A" removed
C - Spring centered, three position

11 Wet Armature Solenoid

(non-serviceable core tubes)
Blank - Flying lead coils
U - DIN 43650 coils w/o electrical plug

12 Coil Type

7 - Coil with surge suppression
(DC models only 12 & 24V DC)

13 Coil Identification Letters

14 Design

15 Left Hand Assembly
(omit for right-hand assembly)

Light Kits

Solenoid Indicator Light Kit
(Includes all parts identified)

Voltage Range	Kit
100 thru 127	941615
192 thru 233	941617

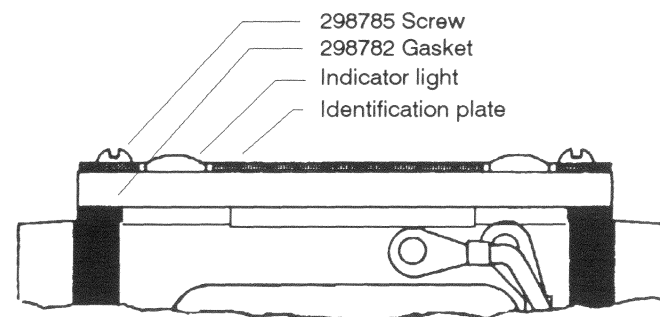

Wet Armature Directional Control Valves

DG4S4-01*B/C-(U)-*-60

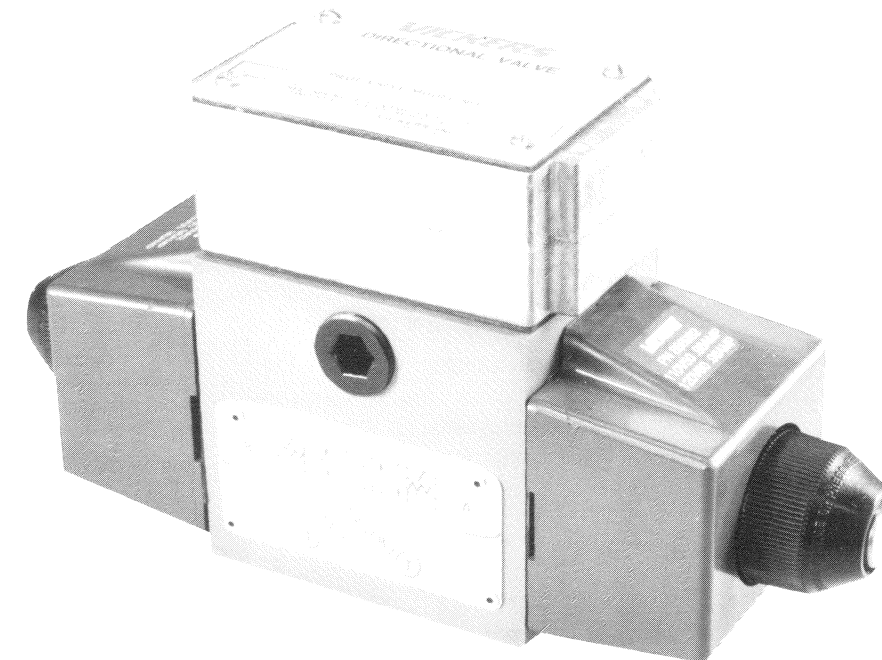

A TRIVIVA Company

Vickers, Incorporated
5445 Corporate Drive
P.O. Box 302
Troy, Michigan 48007-0302
Phone: 810-641-4500
Fax: 810-641-4948

COIL S/A	COIL KIT	VOLTAGE		DC VOLT	COIL CODE	DIN COIL-KIT	
		60 HZ	50 HZ				
868982	892995	120	110		B	893007	879141
868983	892996	240	220		D	893008	879143
868984	892997	460	440		M	893009	879231
868985	892998		127		EG	893010	879232
879211			240		ED		879142
879212			110		A		879144
879213			220		C		879227
879214			24		NN		879228
879215	893003	100	100		T	893015	879229
879216	893004	380	380		DZ	893016	879230
02-101843		24	24		N		02-101845
02-101976		200	200		OV		02-127060
868987	892999			12	G	893011	879146
868988	893000			24	H	893012	879147
868989	893001			48	J	893013	879148
868990				110	P		879226
868991				100	R		879225
868992	893002			250	X	893014	879224
879233				125	DP		879149
02-119664		48	48		K		02-127061
02-119665			48		KK		02-127062
02-119666		24			NV		02-127063
02-300515		220			DN		02-300519
02-300516		115			EK		02-300520
02-300517		110	100		BX		02-300521
02-300518		320	200		DX		02-300522

Spool Assembly Notes

Assembly type "1" spool with relieved land towards "A" port.
 Assembly type "3" spool with narrow land towards "A" port.
 Assembly type "11" spool with relieved land towards "B" port.
 Assembly type "31" spool with narrow land towards "B" port.

Type "68C" is the same as type "6" except solenoid is assembled on opposite end (do not reverse solenoid on "68B" models) and a different diagram plate is used. Type "68C/B" models are used as pilots for spring centered two stage valves with "4" or "8" type spools only.

Type "78C" is the same as type "7" except solenoid is assembled on opposite end (do not reverse solenoid on "78B" models) and a different diagram plate is used. Type "78C/B" models are used as pilots for pressure centered two stage valves with "4" or "8" type spools only.

Type 8C spools. Solenoid designations are reversed.

Type 8B spools. Left hand assembly with coil "A" shown. For right hand assembly, all parts of valve except spool and body are reversed.

SPOOL TYPE	PART	SPOOL KIT
0	463385	892977
1	463386	892978
11	463386	892988
2	463387	892979
3	463388	892980
31	463388	892981
6	880886	892983
68	880886	892984
7	463390	892985
78	463390	892986
8	463391	892987
33	463392	892982

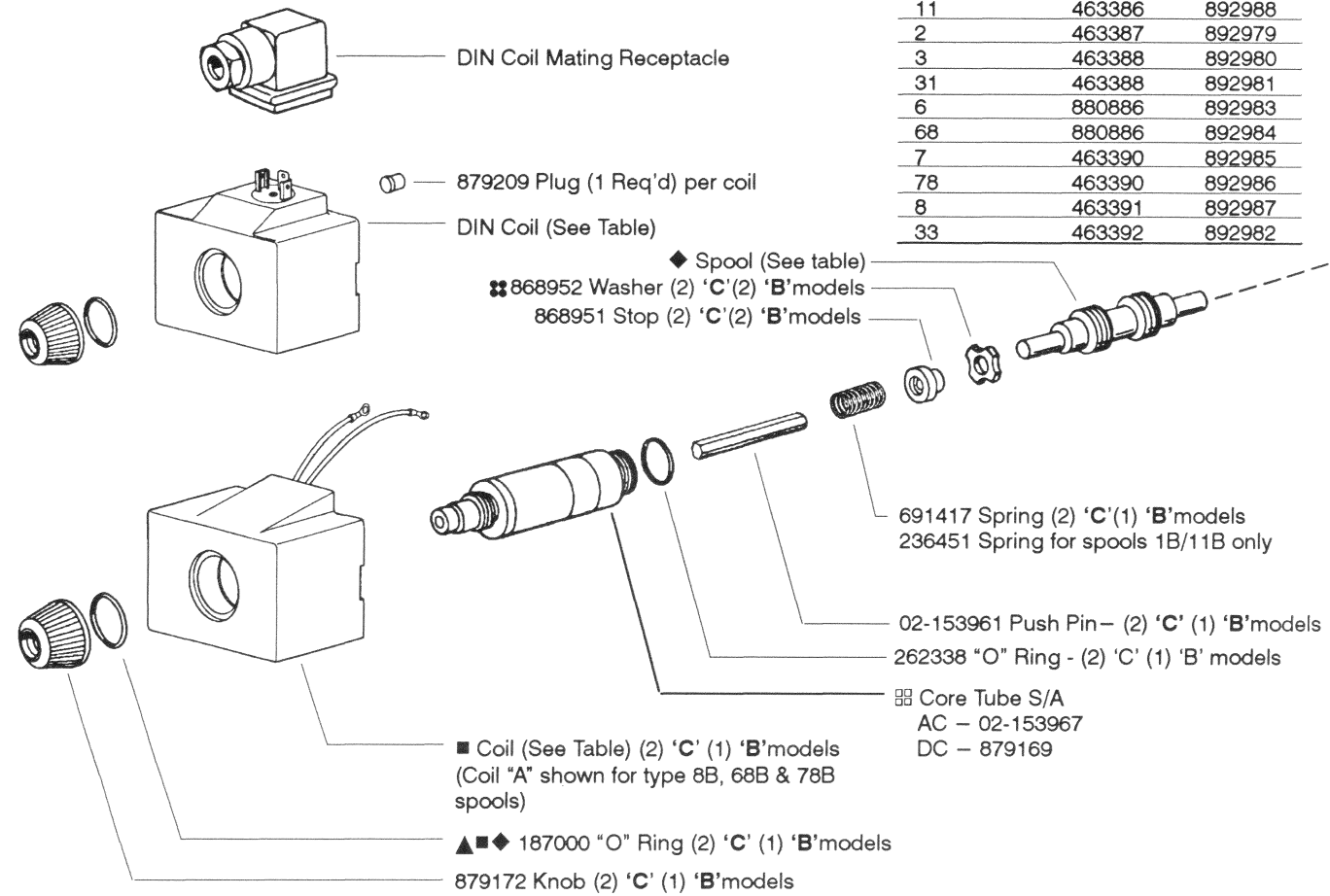

NOTE
 For satisfactory service life of these components in industrial applications, use full flow filtration to provide fluid which meets ISO cleanliness code 18/15 or cleaner.

SPOOL TYPE	DIAGRAM PLATE
11 & 31	290339
8	290340
0	290341
1	290342
2	290343
3	290344
6	290345
7	290346
68	577480
78	577482
33	577484

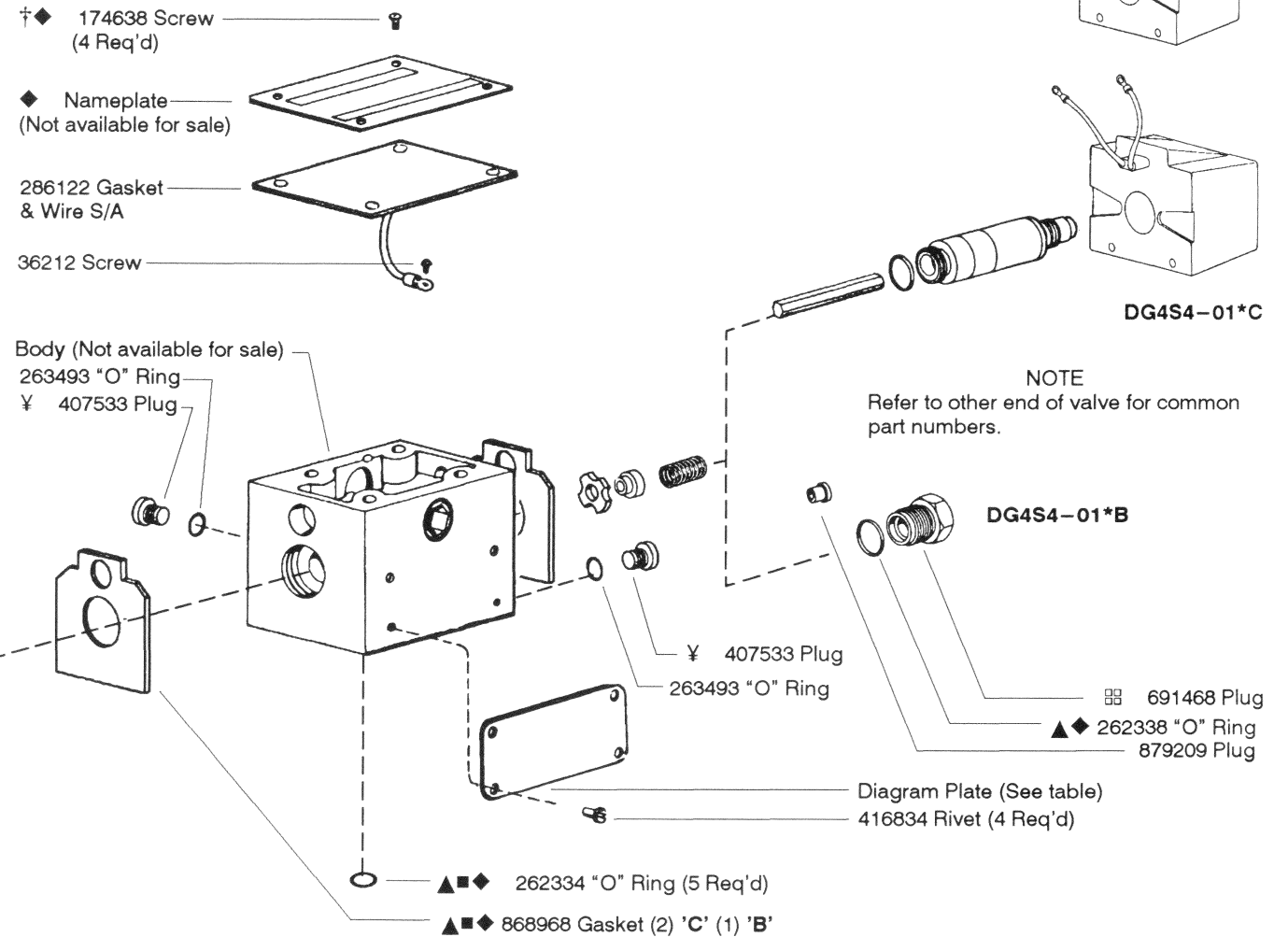

DC Coils with Surge Suppression Device Encapsulated

Coil S/A	DC Voltage	DIN Coil S/A	Coil Code
02-154795	12	02-154798	G
02-154767	24	02-154796	H

Refer to model code for ordering with surge suppression.

Spool/Spring Arrangement Note
 B models only
 Right hand assembly shown (except type '8').
 For left hand assembly (-LH models), all parts of valve except spool and body are reversed. Use left hand diagram plate.

- ▲ Included in F3 Seal Kit 892976
- ◇ Included in Fastener Kit 893005
- ◆ Included in Spool Kit
- Included in Coil Kit
- ⊞ Rounded face on 868952 washer must mate with spool
- ⊞ Torque 24-29 N.m (18-22 lbf. ft.)
- ¥ Torque 12.1-12.4 N.m (107-110 lbf. in.)
- † Torque 0.8-1.01 N.m (7-9 lbf. in.)