



Service Parts Information

Multi-Pressure Relief Valve

CG/CS/CT-06-**-*(*)-(V)-DG8BL-M(***)-M-**-*-30
 CG/CS/CT-10-**-*(*)-(V)-DG8BL-M(***)-M-**-*-30

MODEL CODE BREAKDOWN

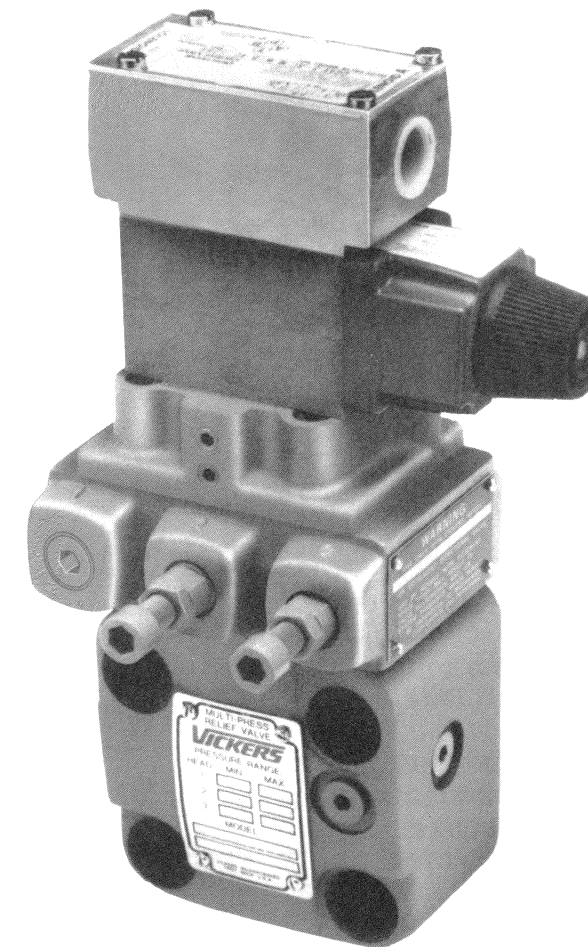
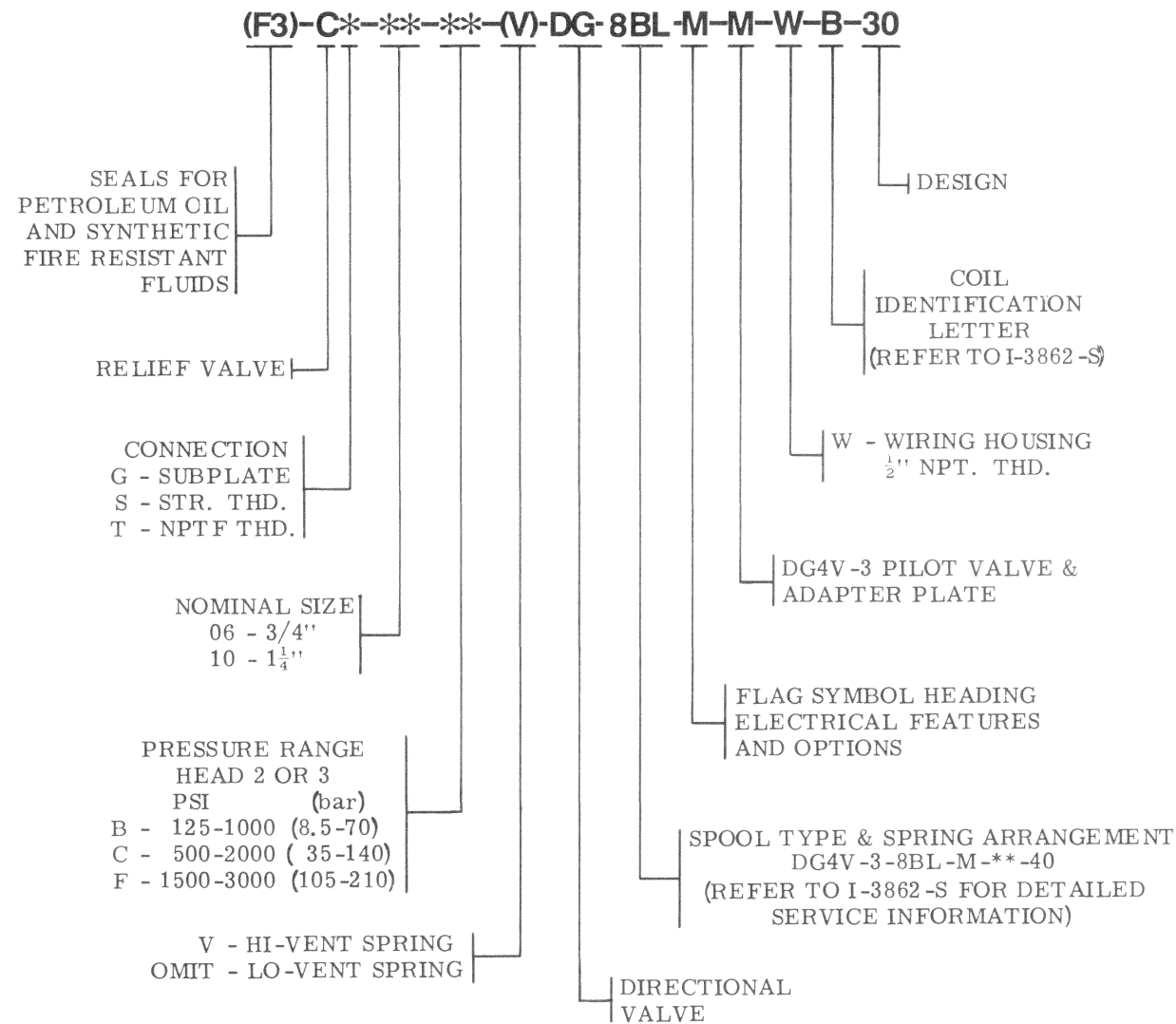

Vickers, Incorporated

1401 Crooks Road
Troy, Michigan 48084

Released 8-1-86

I-3694-S

For satisfactory service life of these components in industrial applications, use full flow filtration to provide fluid which meets ISO cleanliness code 18/15 or cleaner. Selections from Vickers OFP, OFR, and OFRS series are recommended.

Litho in U. S. A.

DG4V-3-8BL-M-**-40-S288
PILOT VALVE (REFER TO
I-3862-S FOR PARTS
INFORMATION)

255698 BOLT KIT
TORQUE 40-50 lb. in.
(4.5-5.6 N. m)
(PILOT VALVE TO
ADAPTER PLATE)
(NOT SHOWN)

255651 BOLT KIT
TORQUE 11-15 lb. ft.
(14.9-20.3 N. m)
(ADAPTER PLATE
TO COVER)

422814 ADAPTER PLATE
113000 PLUG (4 REQ'D)

▲▲262334 "O" RING (4 REQ'D)
226816 ROLLPIN
1649 BALL (2 REQ'D)
(C*-06 ONLY)

COVER (SEE TABLE)

HEAD 1 (INOPERATIVE)
(SEE SECTIONAL VIEW)

290057 PISTON (2 REQ'D)
COVER SPRING (SEE TABLE)
▲▲262332 "O" RING (2 REQ'D)

▲▲197570 BACK-UP
RING (2 REQ'D)

370701 PLUNGER
(2 REQ'D)

○326317 WASHER (AS REQ'D)

○64520 WASHER (AS REQ'D)

*283949 LOCKSCREW (2 REQ'D)

*1485 LOCKNUT (2 REQ'D)

*292230 ADJ. SCREW (2 REQ'D)

WARNING
USE ONLY A DG4V-3-8BL-M-**-40-S288
DIRECTIONAL VALVE AS A PILOT FOR
THIS RELIEF VALVE. USE OF A DIF-
FERENT PILOT CAN BLOCK RELIEF
VALVE, CAUSING EXCESSIVE SYSTEM
PRESSURE.

**SECTIONAL
HEAD 1 INOPERATIVE**

218750 PLUG
370701 PLUNGER
▲▲197570 BACK-UP
RING
▲▲262332 "O" RING
51904 SPACER
(AS REQ'D)
2281 SPRING
290057 PISTON
285601 SEAT
294656 PLUG (C*-10 ONLY)

▲▲263497
"O" RING
329463 PLUG
TORQUE 39-43 lb. ft.
(52.8-58.3 N. m)

**SECTIONAL
'E' VENT
HEAD 2 or 3**

▲▲263497
"O" RING
329463 PLUG
TORQUE 39-43 lb. ft.
(52.8-58.3 N. m)
▲▲262332 "O" RING
▲▲197570 BACK-UP RING
370701 PLUNGER
218750 PLUG

329463 PLUG (2 REQ'D)
TORQUE 39-43 lb. ft.
(52.8-58.3 N. m)

▲▲263497 "O" RING (2 REQ'D)
294656 RESTRICTOR PLUG
(2 REQ'D) (C*-10 ONLY)

285601 SEAT (2 REQ'D)
ASSEMBLE CROSSHOLE
FACING UP

113000 PLUG
(C*-06 5 REQ'D)
(C*-10 7 REQ'D)

370839 WARNING PLATE

227405 SCREW (4 REQ'D)

LOCKWASHER (SEE TABLE)

SCREW (SEE TABLE)
(COVER TO BODY)

| MODEL | SCREW (4 REQ'D) | TORQUE | | L'WASHER (4 REQ'D) |
|-------|--------------------|---------|-----------|-----------------------|
| | | lb. ft. | N. m | |
| C*-06 | 1036 | 11-15 | 14.9-20.3 | 68907 |
| C*-10 | 1076 | 35-43 | 47.5-58.3 | 68909 |

*NOTE
COAT 292230 ADJ. SCREW, 283949
LOCKSCREW AND 1485 LOCKNUT
WITH OIL PRIOR TO ASSEMBLY.

⊖ THIS PART USED AT FINAL
TEST TO OBTAIN CORRECT
PRESSURE RANGE.

| MODEL | "C"RING | SEAT | HYDRO CONE | LO-VENT SPRING | HI-VENT SPRING | COVER |
|-------|----------|--------|---------------|-------------------|-------------------|--------|
| C*-06 | ▲ 262361 | 343153 | 343154 | 2077 | 184458 | 370664 |
| C*-10 | ▲ 262367 | 283954 | 283952 | 291822 | 291821 | 370669 |

NOTE: USE EITHER A LO-VENT OR HI-VENT SPRING.
DO NOT USE BOTH.(SEE MODEL CODE)

| MODEL | COVER SPRING | PRESSURE RANGE PSI (bar) |
|---------|-----------------|--------------------------------|
| C*-**-B | 2280 | 125-1000 (8.5-70) |
| C*-**-C | 583937 | 500-2000 (35-140) |
| C*-**-F | 2281 | 1500-3000 (105-210) |

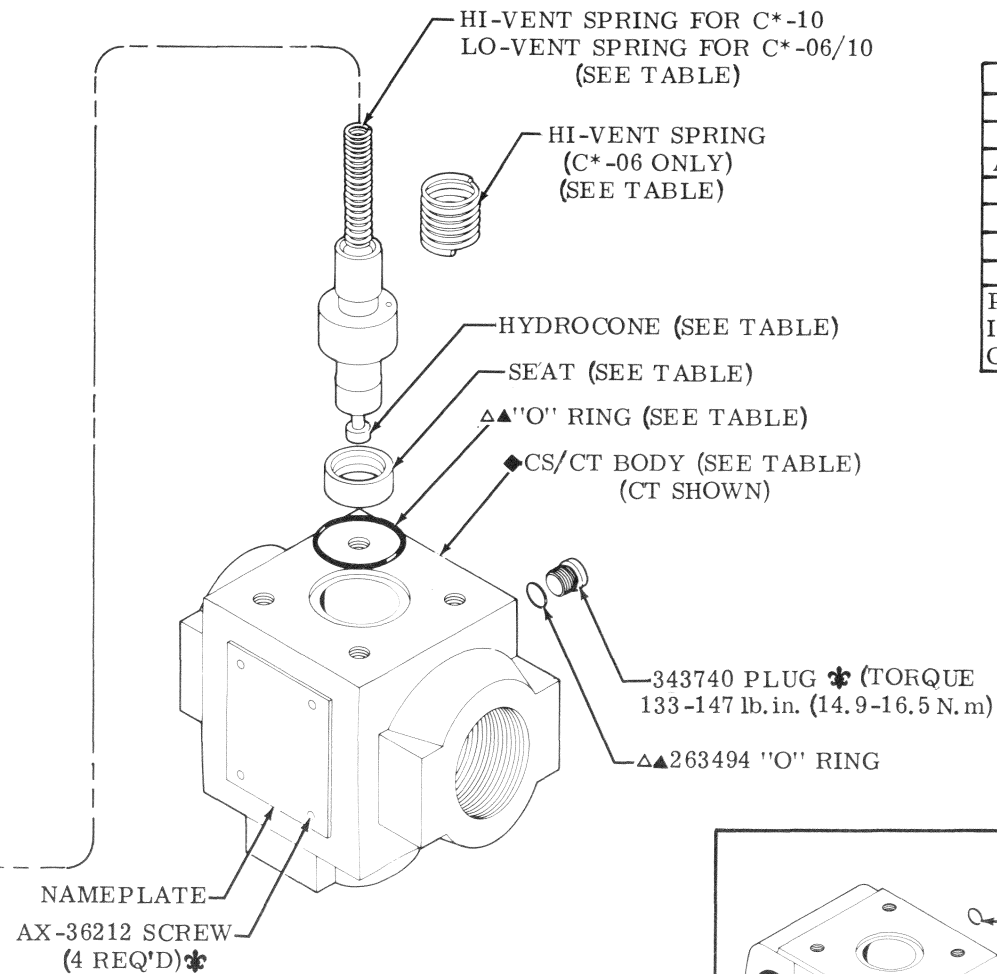

| PART | KIT | PART | KIT |
|----------|--------|--------|--------|
| 1485 | 944064 | 226816 | 944071 |
| 1649 | 944067 | 227405 | 944074 |
| AX-36212 | 944053 | 292230 | 944072 |
| 64520 | 944068 | 326317 | 944073 |
| 113000 | 944055 | 329463 | 944041 |
| 160571 | 944069 | 343740 | 944038 |
| 218750 | 944070 | | |

PARTS WITH * AVAILABLE ONLY
IN KITS OF 25. REFERENCE KIT
ON PARTS ORDER.

| MODEL | ◆BODY | |
|-------|--------|--------|
| | -06 | -10 |
| CG | 580456 | 581703 |
| CS | 581701 | 580430 |
| CT | 590348 | 590300 |

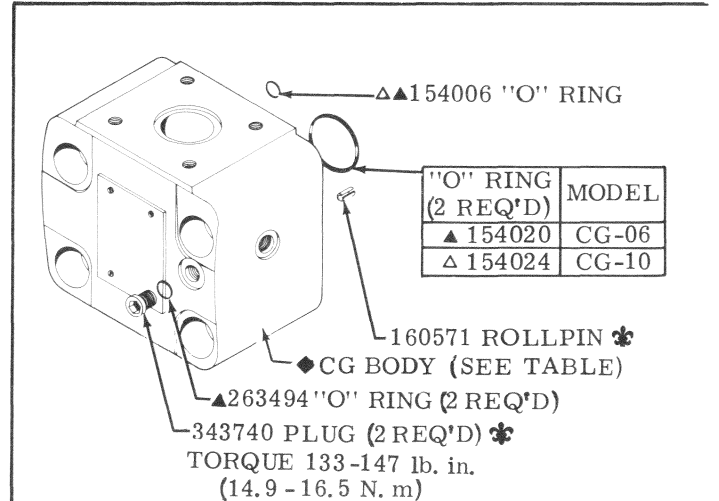

▲ INCLUDED IN -06 F3 SEAL KIT 919684
▲ INCLUDED IN -10 F3 SEAL KIT 919685
◆ NOT AVAILABLE FOR SALE
* AVAILABLE ONLY IN KITS OF 25