

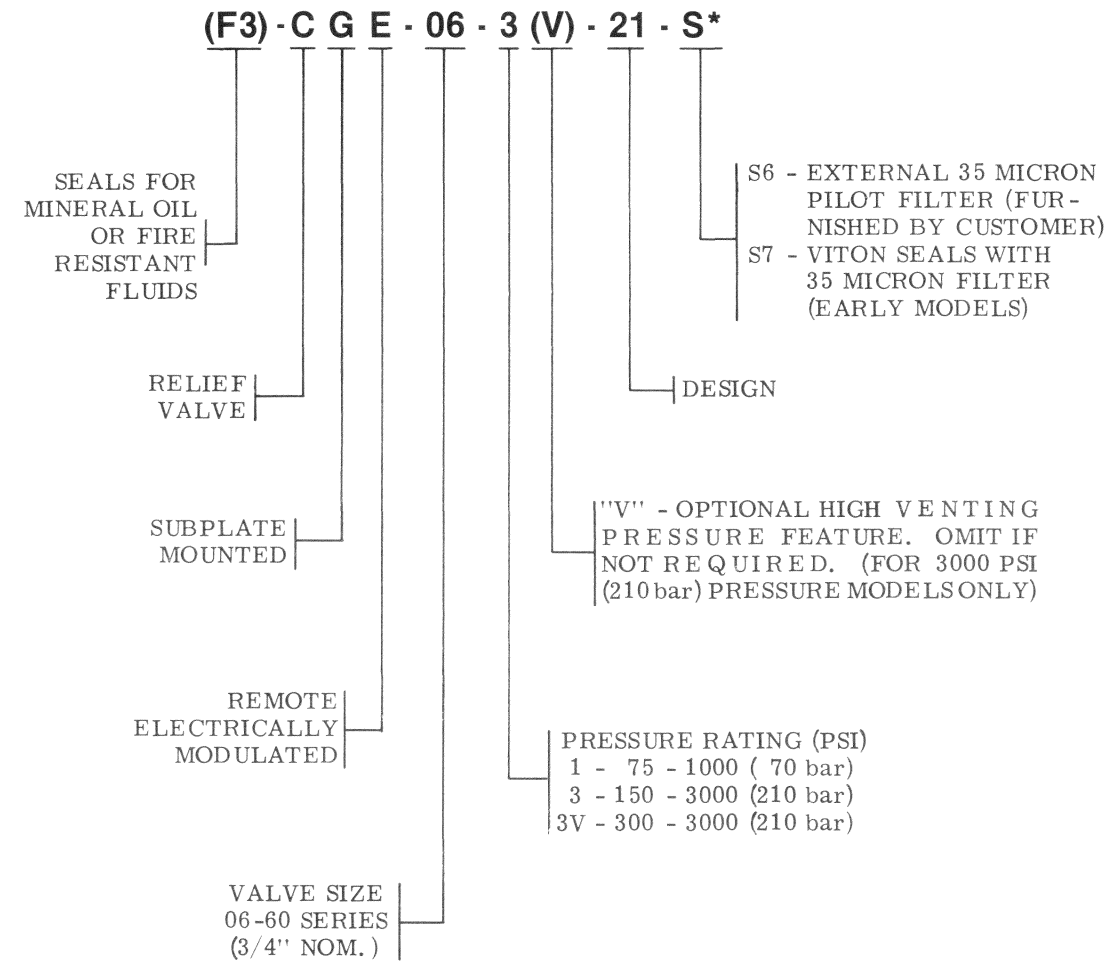

# Service Parts Information

## MODEL CODE BREAKDOWN



Remote  
Electrically  
Modulated  
Relief Valves

CGE-06-1-21  
CGE-06-3(V)-21-(S6)(S7)

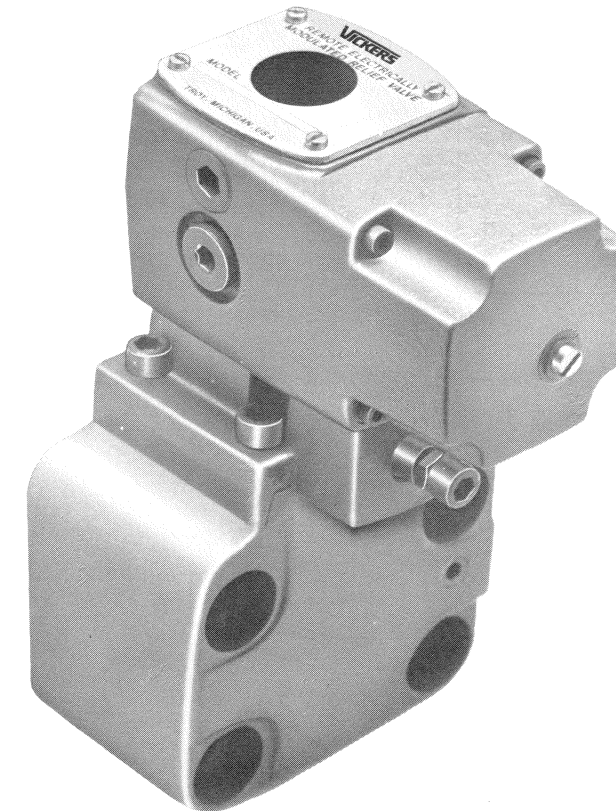

Vickers, Incorporated

1401 Crooks Road  
Troy, Michigan 48084

Revised 1-1-86

I-3675-S

For satisfactory service life of these components, use full flow filtration to provide fluid which meets ISO cleanliness code 18/15 or cleaner. Selections from Vickers OFP, OFR, and OFRS series are recommended.

Litho in U. S. A.

● INCLUDED IN  
COIL KIT 926275

ALL SEALS, EXCEPT INTER-  
FACE, ARE F3. USE THE F3  
SEAL KIT TO SERVICE ALL  
UNITS.

▲ INCLUDED IN F3  
SEAL KIT 920081

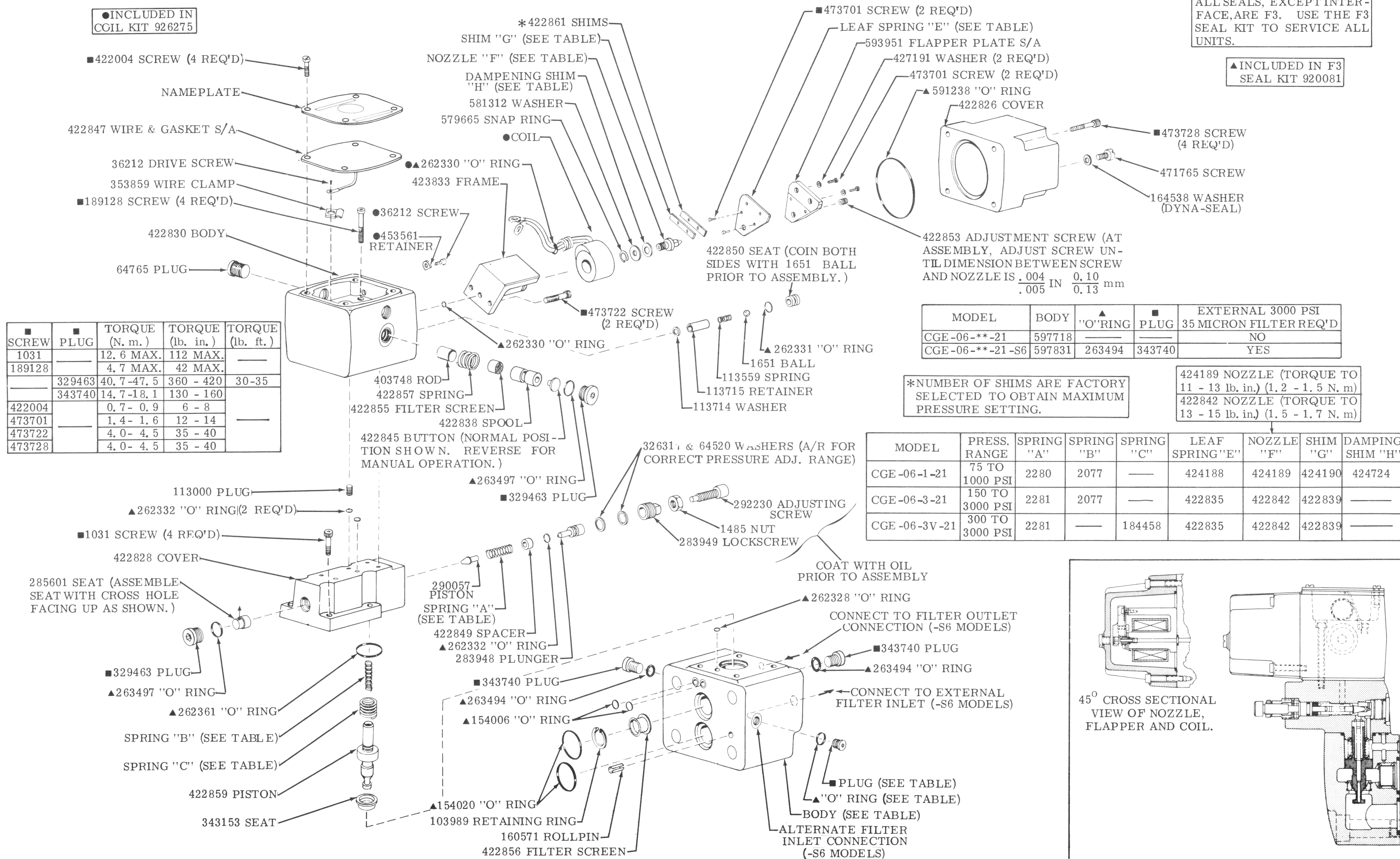

■ SCREW	■ PLUG	TORQUE (N. m.)	TORQUE (lb. in.)	TORQUE (lb. ft.)
1031		12.6 MAX.	112 MAX.	—
189128		4.7 MAX.	42 MAX.	—
	329463	40.7 - 47.5	360 - 420	30 - 35
	343740	14.7 - 18.1	130 - 160	—
422004		0.7 - 0.9	6 - 8	—
473701		1.4 - 1.6	12 - 14	—
473722		4.0 - 4.5	35 - 40	—
473728		4.0 - 4.5	35 - 40	—

MODEL	BODY	▲ 'O' RING	■ PLUG	EXTERNAL 3000 PSI 35 MICRON FILTER REQ'D
CGE-06-**-21	597718	—	—	NO
CGE-06-**-21-S6	597831	263494	343740	YES

\*NUMBER OF SHIMS ARE FACTORY  
SELECTED TO OBTAIN MAXIMUM  
PRESSURE SETTING.

424189 NOZZLE (TORQUE TO  
11 - 13 lb. in.) (1.2 - 1.5 N. m)  
422842 NOZZLE (TORQUE TO  
13 - 15 lb. in.) (1.5 - 1.7 N. m)

MODEL	PRESS. RANGE	SPRING "A"	SPRING "B"	SPRING "C"	LEAF SPRING "E"	NOZZLE "F"	SHIM "G"	DAMPING SHIM "H"
CGE-06-1-21	75 TO 1000 PSI	2280	2077	—	424188	424189	424190	424724
CGE-06-3-21	150 TO 3000 PSI	2281	2077	—	422835	422842	422839	—
CGE-06-3V-21	300 TO 3000 PSI	2281	—	184458	422835	422842	422839	—

