

STROKE ADJUSTMENT PARTS

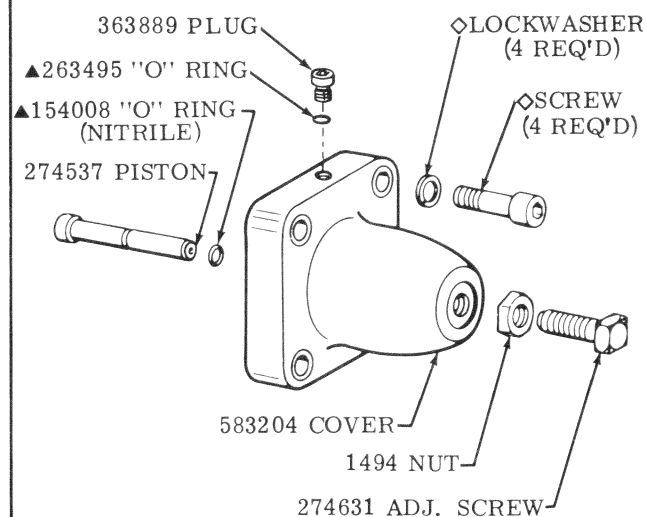

◆ORDER COMPLETE CHOKE (DGFN-01-20) IF BODY IS REQ'D.

△STD. NITRILE SEALS SHOWN. USE F3 SEAL KIT 919218 FOR SERVICE.

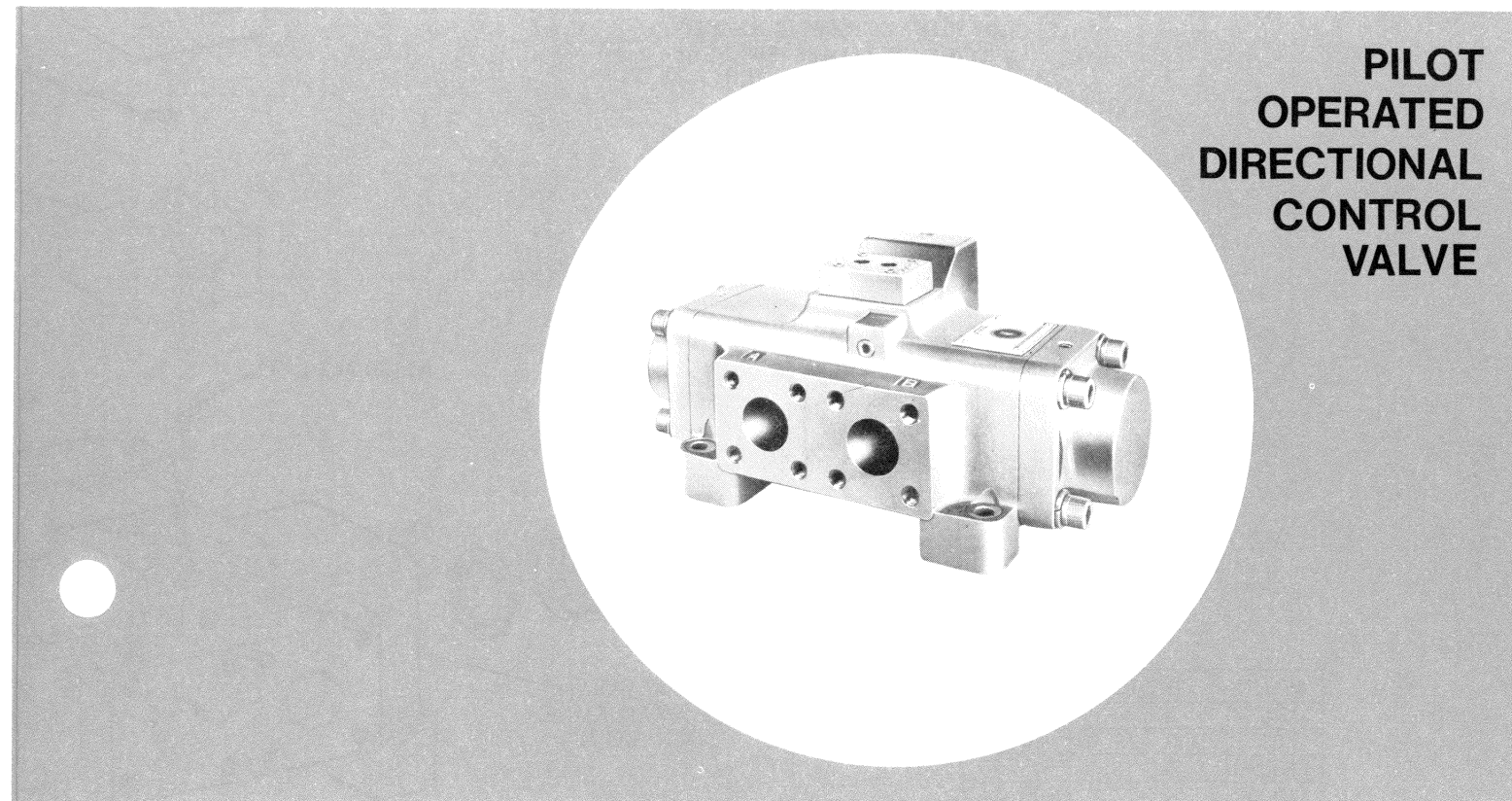

PILOT OPERATED DIRECTIONAL CONTROL VALVE

MODEL CODE BREAKDOWN

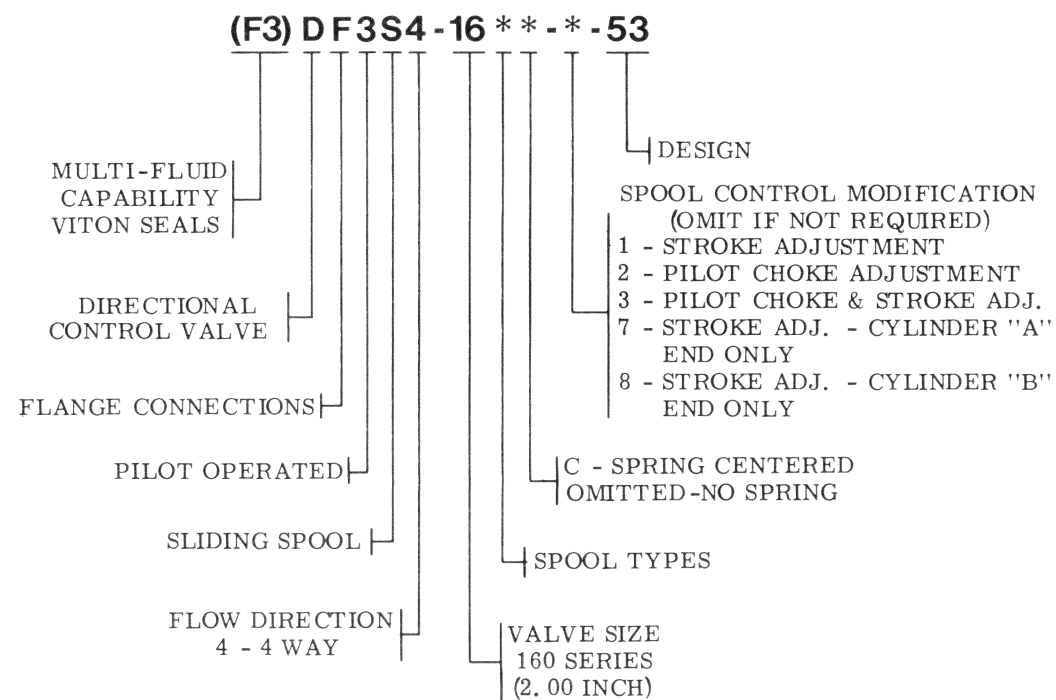

SERVICE PARTS INFORMATION

DF3S4-16-*-53**

To insure sustained efficiency and maximum trouble-free life of this precision equipment, initial and continuous filtration of the fluid medium to 35 microns absolute or less is essential. (For information pertaining to Sperry Vickers economical filters, see bulletin 81-216.)

COVER ATTACHING BOLTS	
MODEL	BOLT (4 REQ'D)
W/PILOT CHOKE	▣10936
W/OUT PILOT CHOKE	□ 1033
TORQUE TO 100 - 112 lb. in. (11.3 - 12.7 N. m)	

MODEL	SPOOL	IDENT. PLATE	
		"C"	NO-SPRING
DF3S4-160(C)-*-53	273677	400976	400975
DF3S4-161C-*-53	*386581	400977	—
DF3S4-162(C)-*-53	273676	400978	400975
DF5S4-163C-*-53	*275803	400979	—
DF3S4-164C-*-53	*273720	400980	—
DF3S4-166(C)-*-53	275804	400981	400975
DF3S4-168C-*-53	*275805	400980	—
DF3S4-169(C)-*-53	275806	400976	400975
DF3S4-1631C-*-53	275803	580475	—
DF3S4-1633C-*-53	317777	400981	—

* SEE SPOOL ASSEMBLY NOTE BELOW

NOTE
PART NUMBERS INCLUDED IN KITS
WILL NOT BE SOLD SEPARATELY

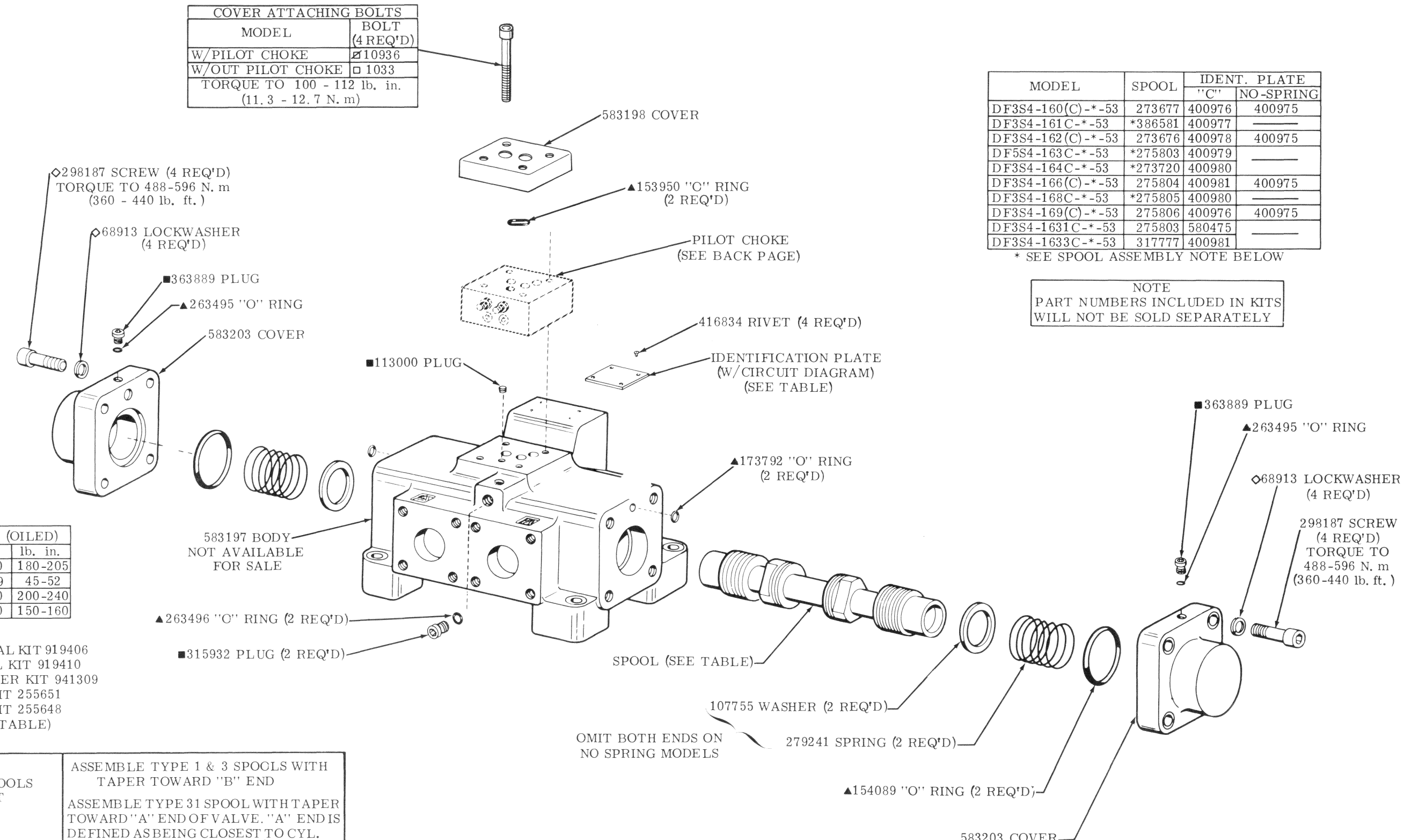

■ PLUG TORQUES (OILED)			
PLUG	N. m	lb. in.	
7075	20.0 -23.0	180-205	
113000	5.0 - 5.9	45-52	
315932	22.5 -27.0	200-240	
363889	16.9 -18.0	150-160	

- ▲▲ INCLUDED IN STD. SEAL KIT 919406
- F3 EQUIVALENT SEAL KIT 919410
- ◇ INCLUDED IN FASTENER KIT 941309
- INCLUDED IN BOLT KIT 255651
- ▣ INCLUDED IN BOLT KIT 255648
- PLUG TORQUES (SEE TABLE)

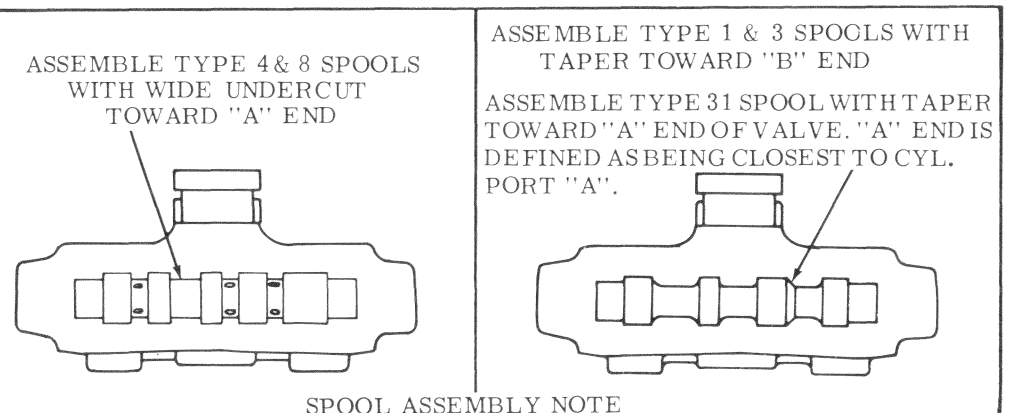

SPOOL ASSEMBLY NOTE

NOTE
SAE STRAIGHT THREAD PLUGS
USED ON EXTERIOR OF VALVE

- ▲ INCLUDED IN 919406 SEAL KIT
- F3 EQUIVALENT SEAL KIT 919410
- SEE PARTS DRAWING I-3962-S FOR CONNECTION FLANGES