

MODEL CODE BREAKDOWN

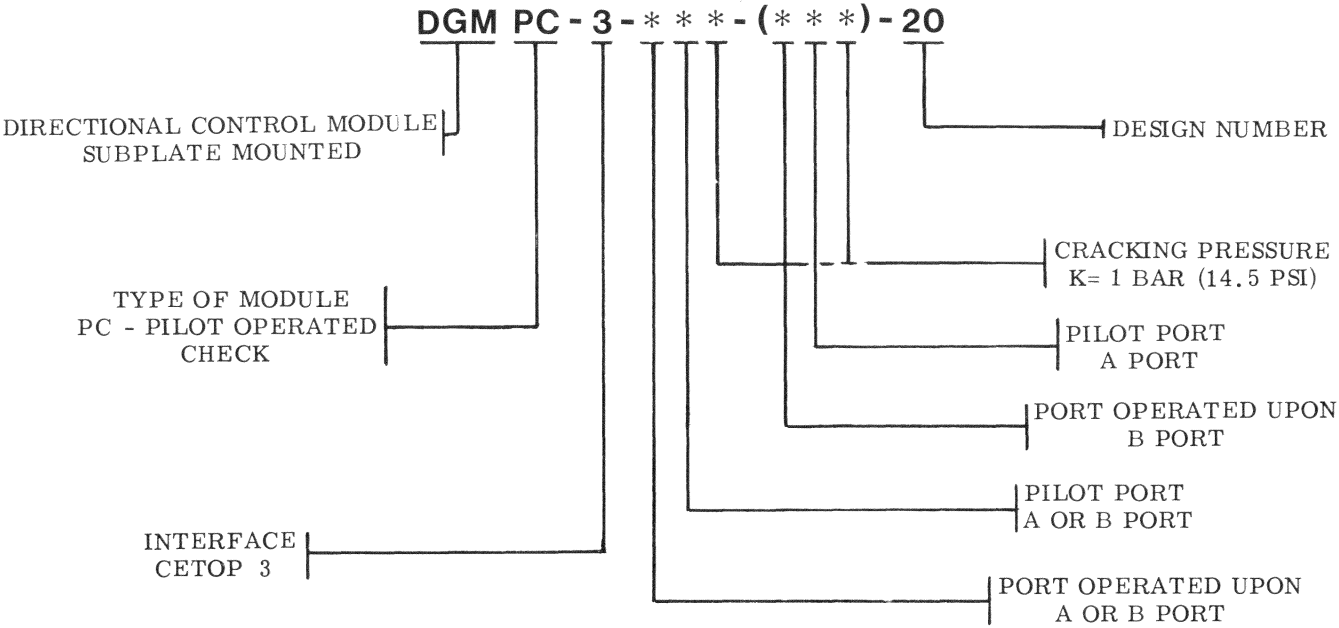

OMIT CODING IN PARENTHESIS FOR SINGLE
PILOT OPERATED CHECK VALVE

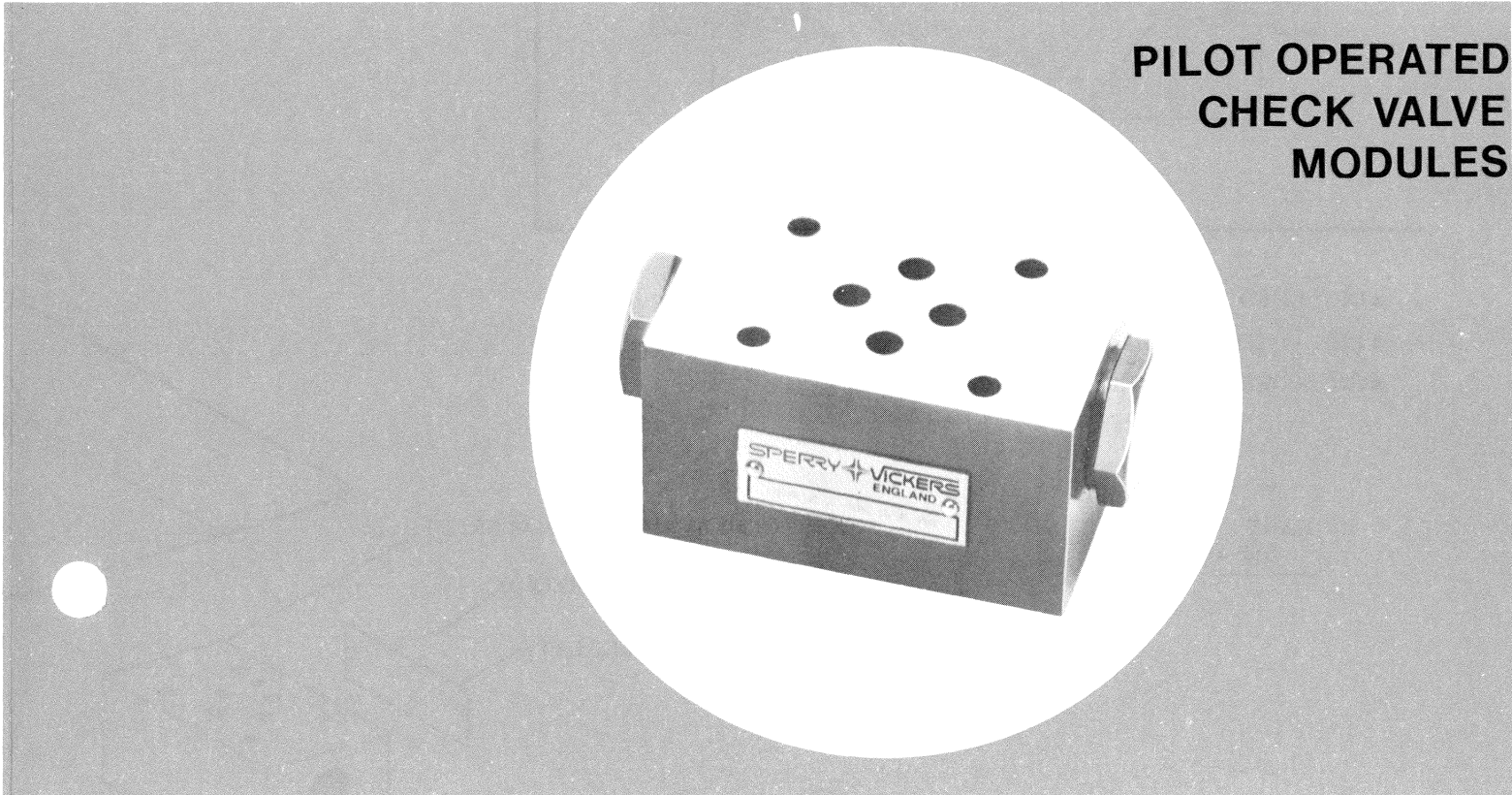

**SERVICE
PARTS
INFORMATION**

DGMPC - 3 - * * * - (* * *) - 20

To insure sustained efficiency and maximum trouble-free life of this precision equipment, initial and continuous filtration of the fluid medium to 35 microns absolute or less is essential. (For information pertaining to Sperry Vickers economical 3 or 10 micron filters, see installation drawing 522140.)

Litho in U. S. A.

PILOT OPERATED CHECK VALVE MODULES

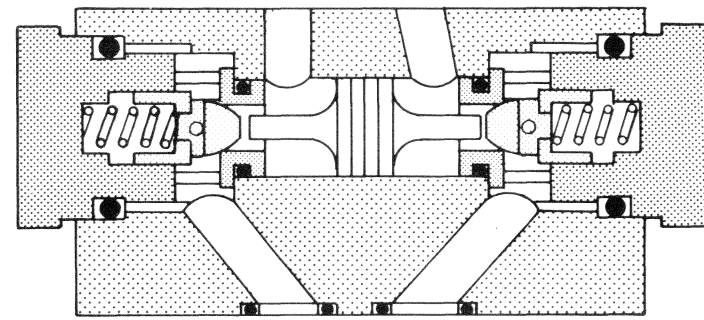

- ▲ INCLUDED IN SEAL KIT 941001
- INCLUDED IN PLUG KIT 941187
- INCLUDED IN SPOOL & POPPET KIT 941188

NOTE
PARTS AVAILABLE IN
KIT FORM ONLY

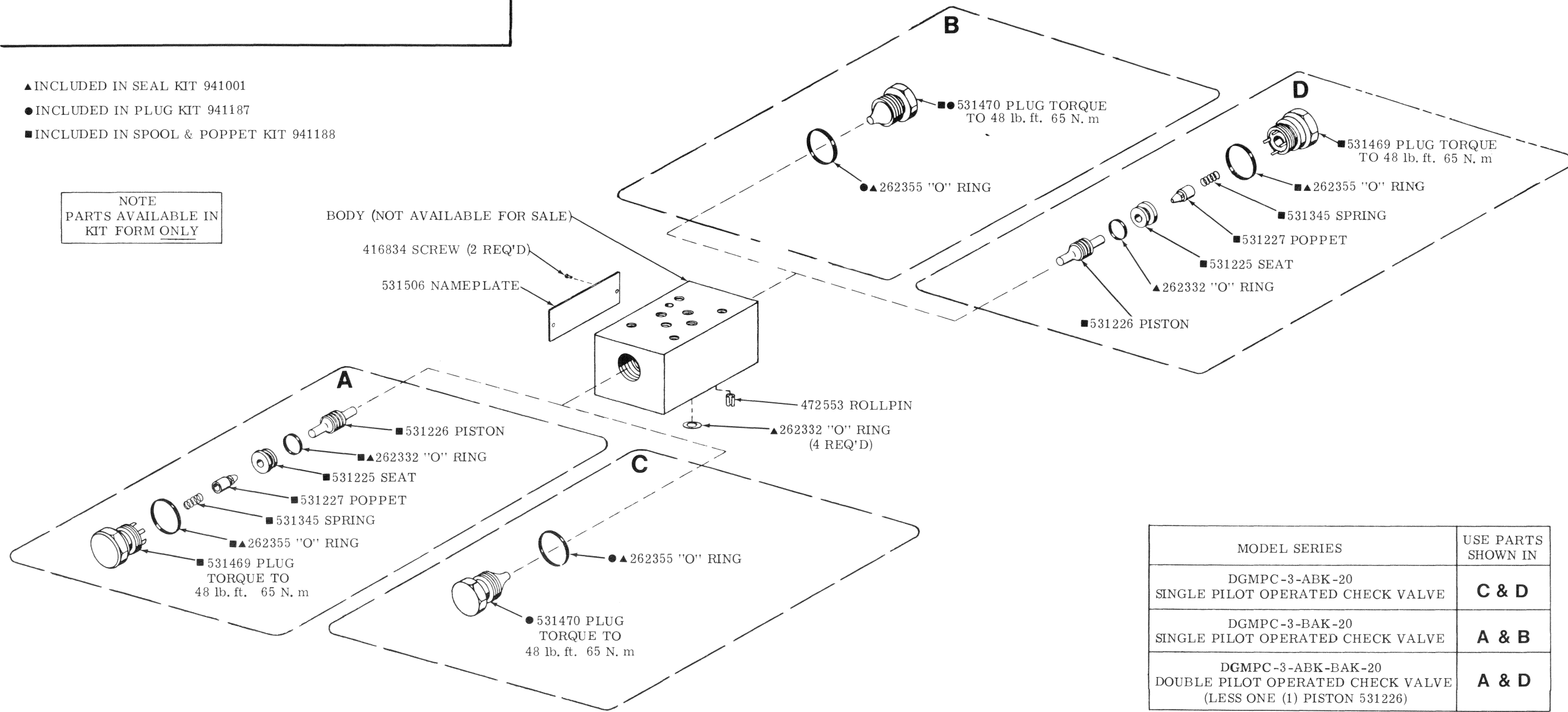

MODEL SERIES	USE PARTS SHOWN IN
DGMPC-3-ABK-20 SINGLE PILOT OPERATED CHECK VALVE	C & D
DGMPC-3-BAK-20 SINGLE PILOT OPERATED CHECK VALVE	A & B
DGMPC-3-ABK-BAK-20 DOUBLE PILOT OPERATED CHECK VALVE (LESS ONE (1) PISTON 531226)	A & D