

MODEL CODE BREAKDOWN

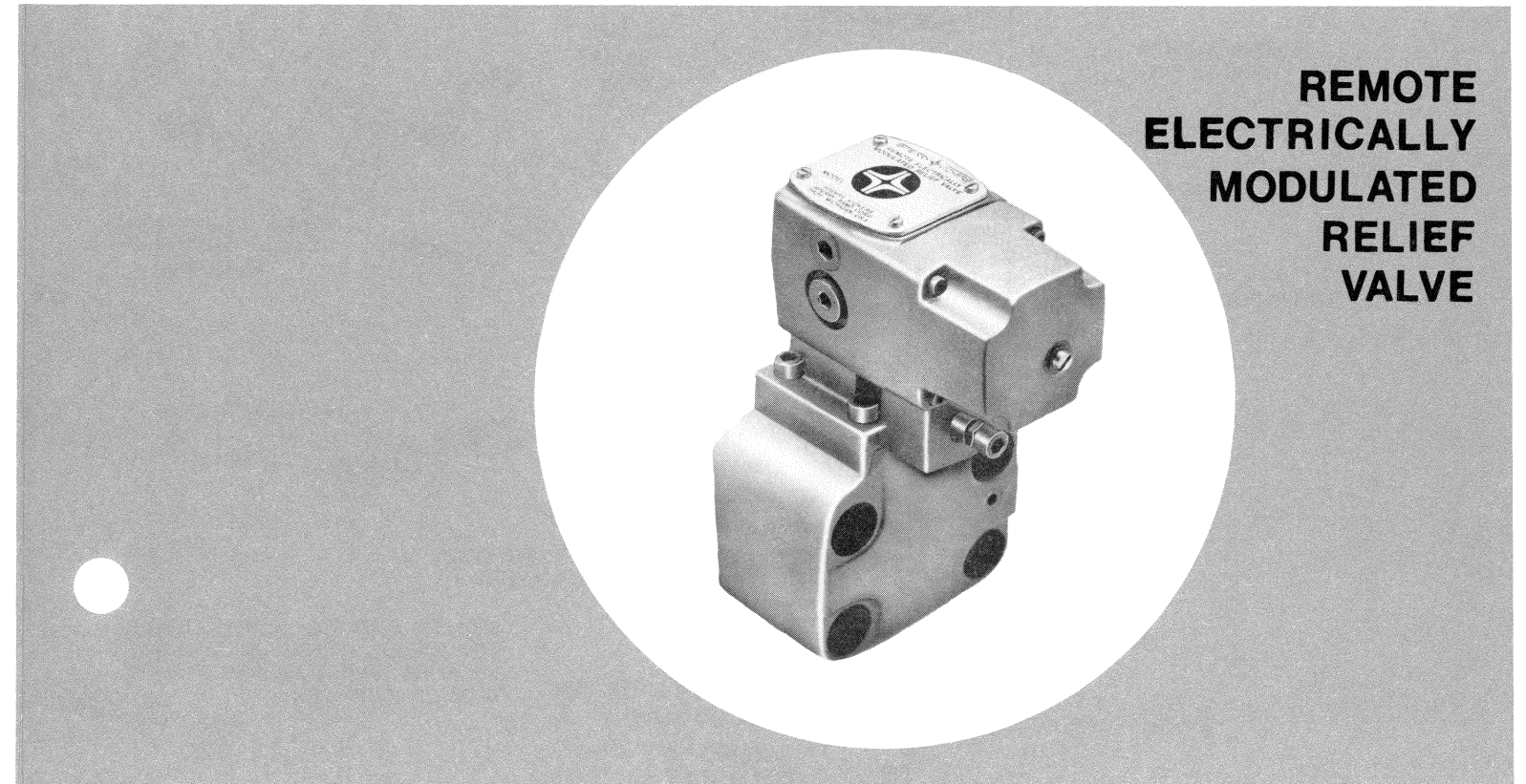
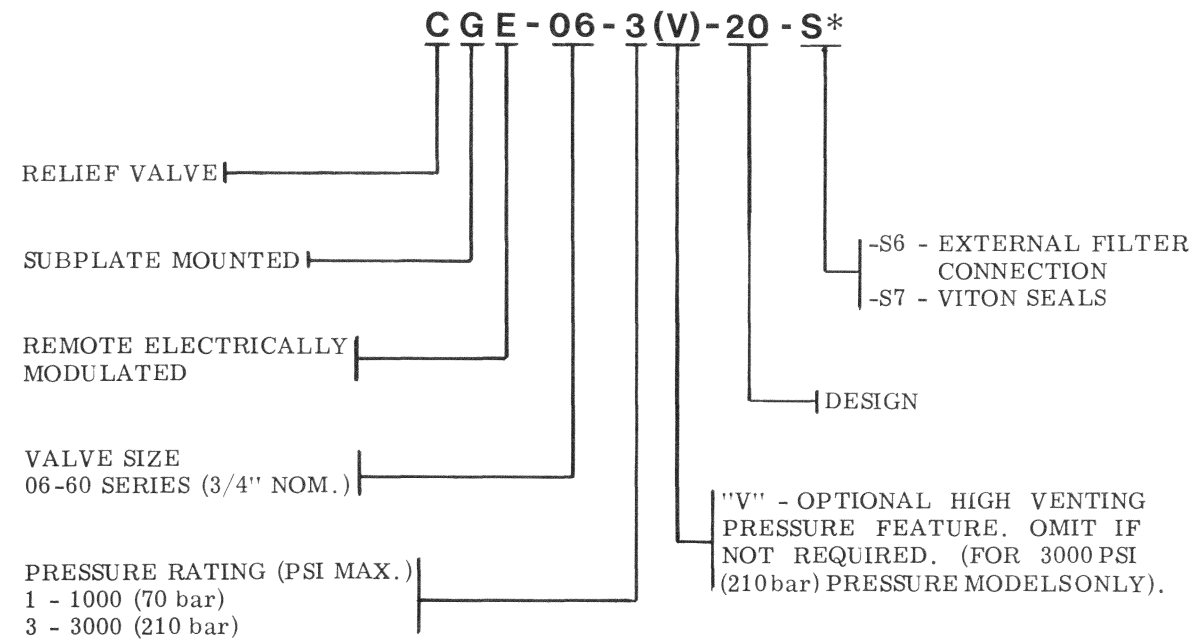

SERVICE PARTS INFORMATION

CGE-06-1-20
CGE-06-3(V)-20

To insure sustained efficiency and maximum trouble-free life of this precision equipment, initial and continuous filtration of the fluid medium to 25 microns absolute or less is essential. (For information pertaining to Sperry Vickers economical 3 or 10 micron filters, see installation drawing 522140.)

