

MODEL CODE BREAKDOWN

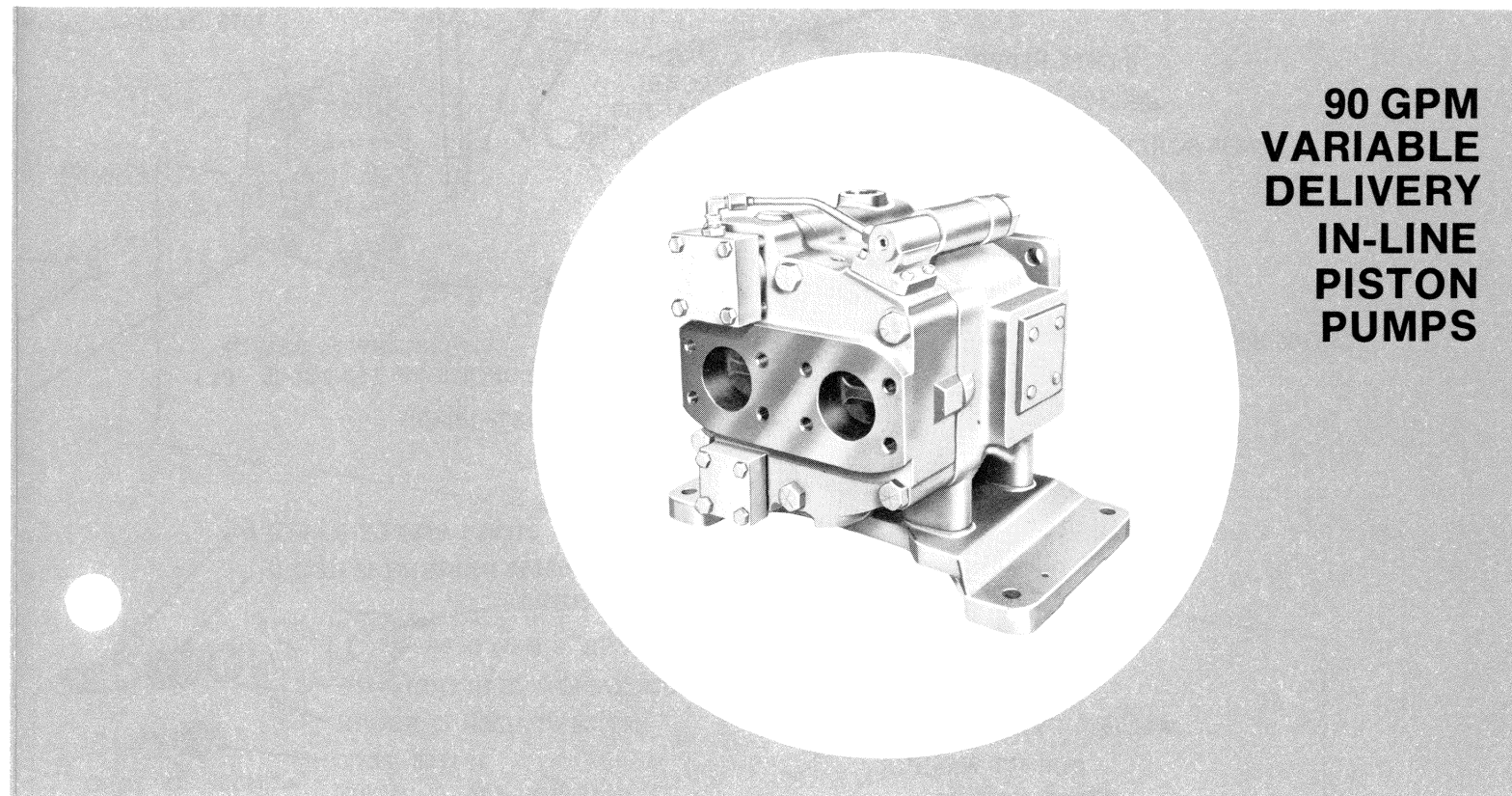
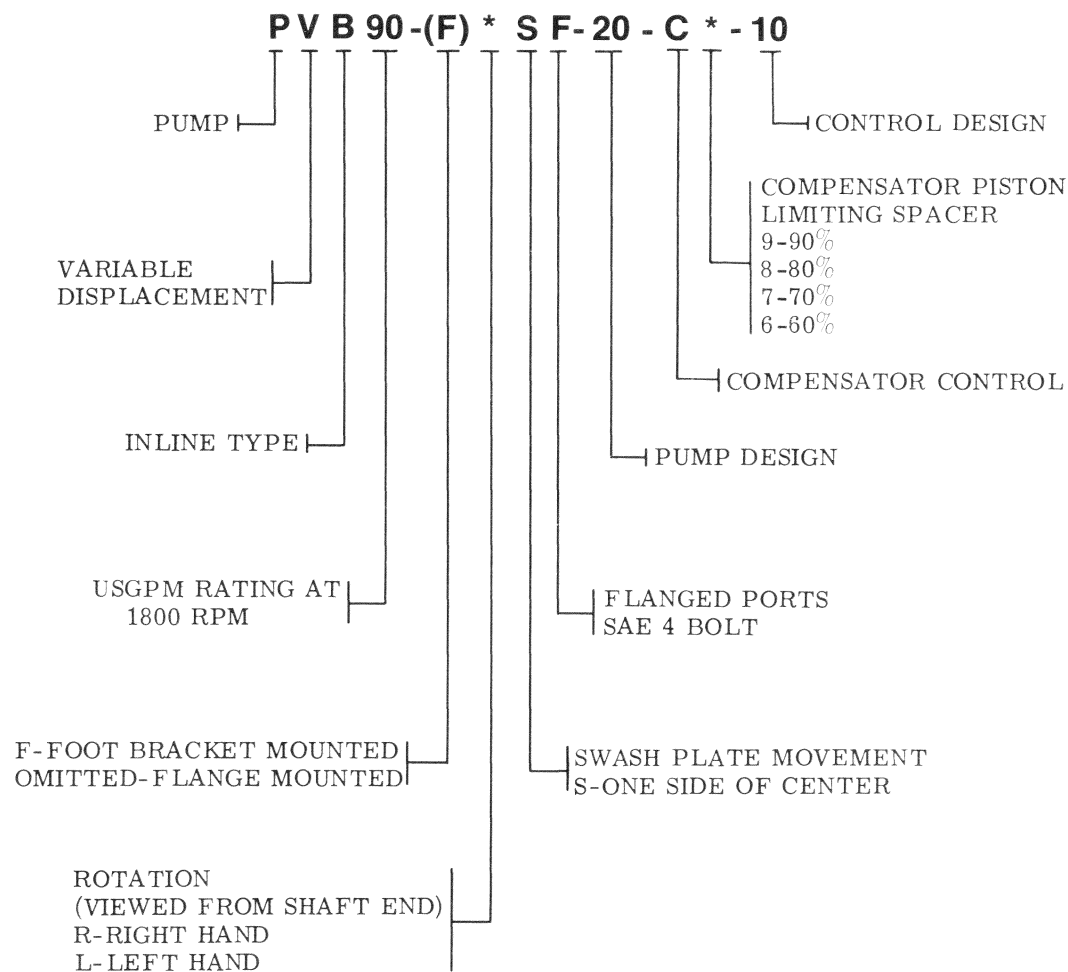

**90 GPM
VARIABLE
DELIVERY
IN-LINE
PISTON
PUMPS**

**SERVICE
PARTS
INFORMATION**

**PVB90-(F)RSF-20-C-10
PVB90-(F)LSF-20-C-10**

To insure sustained efficiency and maximum trouble-free life of this precision equipment, initial and continuous filtration of the fluid medium to 25 microns absolute or less is essential. (For information pertaining to Sperry Vickers economical 3 or 10 micron filters, see installation drawing 522140.)

Litho in U. S. A.

Revised 12-1-78

SPERRY VICKERS
TROY, MI. 48084

I-3290-S

SPACER TABLE	
PART NO.	MODEL
342767	C9
342768	C8
342769	C7
342770	C6

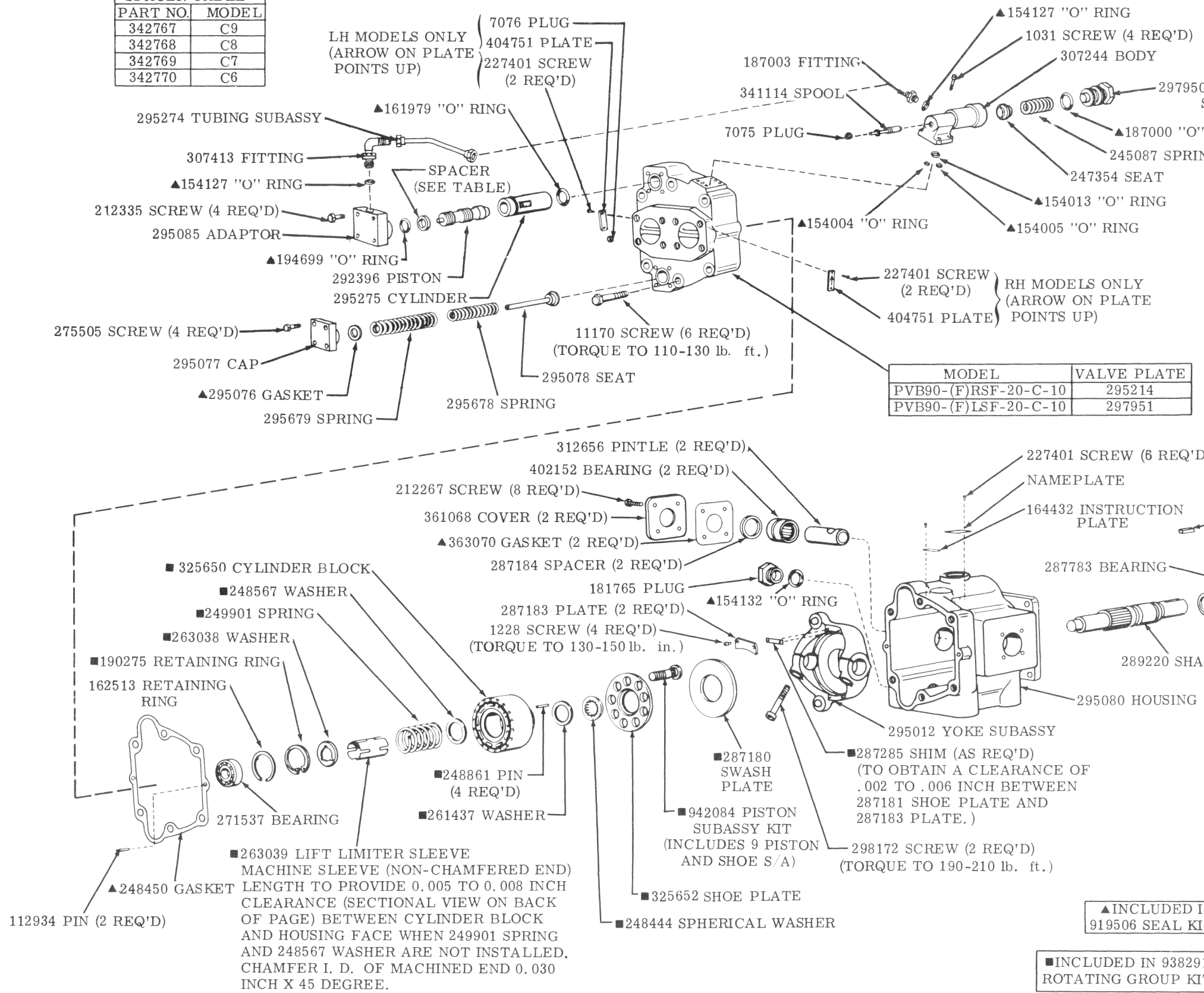

MODEL	VALVE PLATE
PVB90-(F)RSF-20-C-10	295214
PVB90-(F)LSF-20-C-10	297951

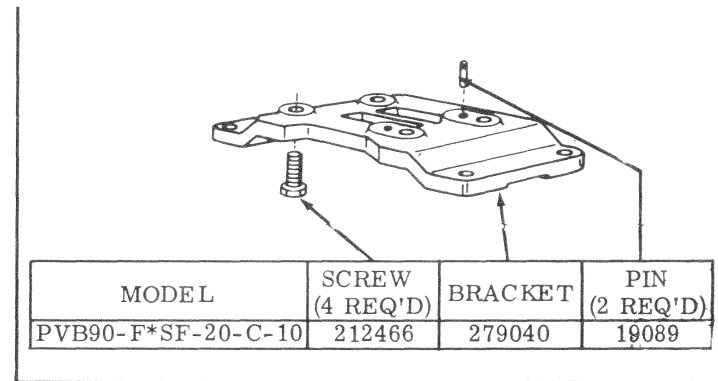

- ▲ INCLUDED IN 919506 SEAL KIT
- INCLUDED IN 938291 ROTATING GROUP KIT

