

MODEL CODE BREAKDOWN

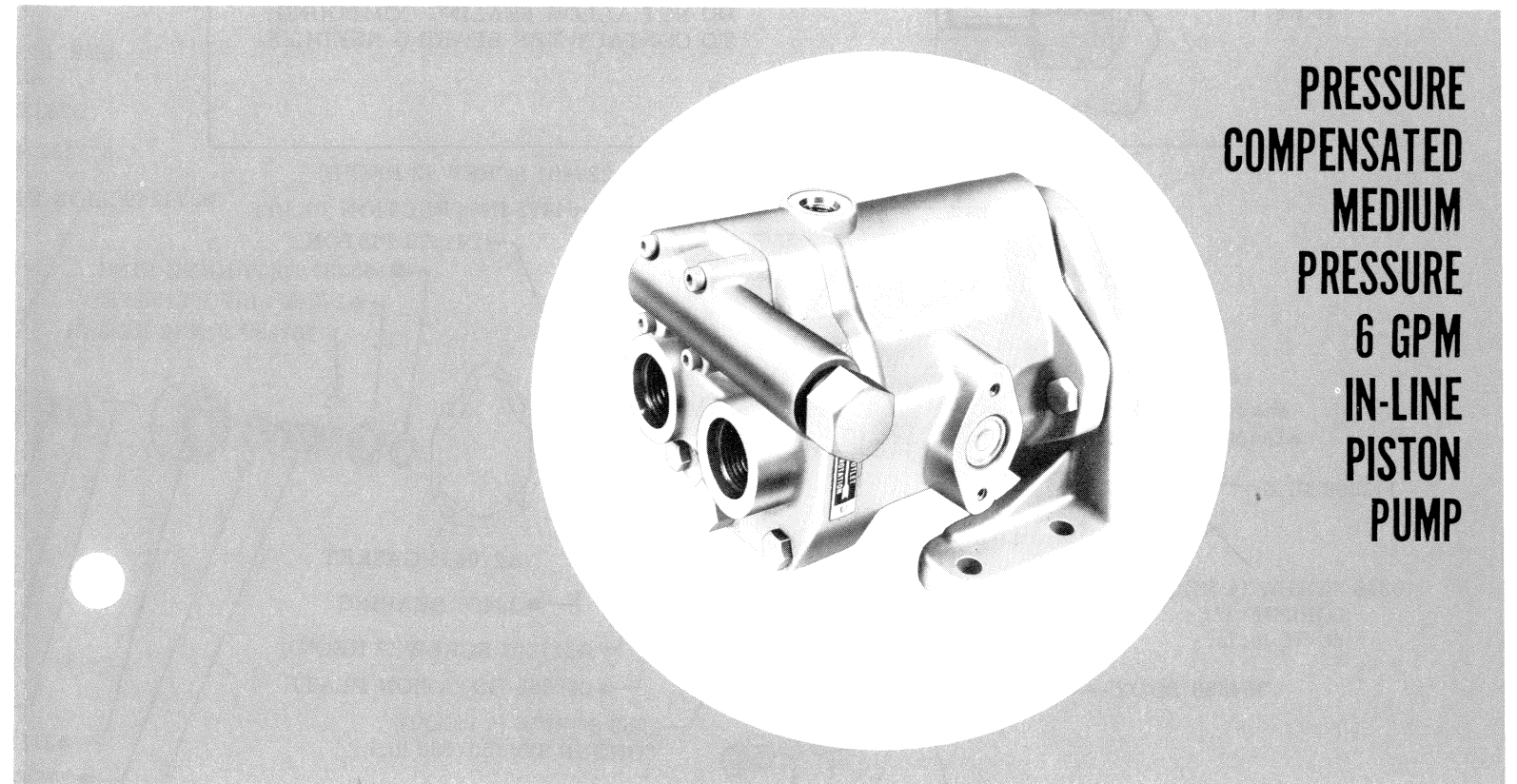
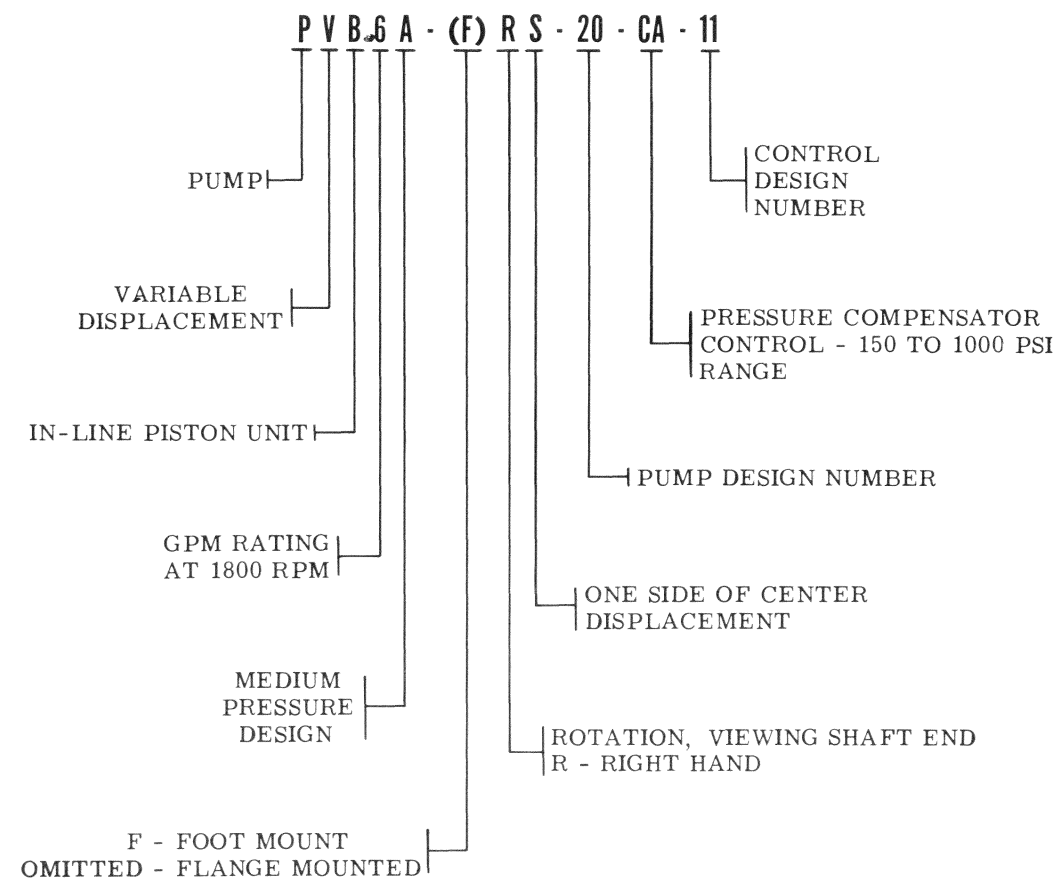

**PRESSURE
COMPENSATED
MEDIUM
PRESSURE
6 GPM
IN-LINE
PISTON
PUMP**

**SERVICE
PARTS
INFORMATION**

PVB6A-(F)RS-20-CA-11

To insure sustained efficiency and maximum trouble-free life of this precision equipment, initial and continuous filtration of the fluid medium to 25 microns absolute or less is essential. (For information pertaining to Sperry Vickers economical 3 or 10 micron filters, see installation drawing 522140.)

Litho in U. S. A.

SPERRY VICKERS
TROY, MI. 48084

Revised 8-1-79

I-3281-S

