

MODEL CODE BREAKDOWN

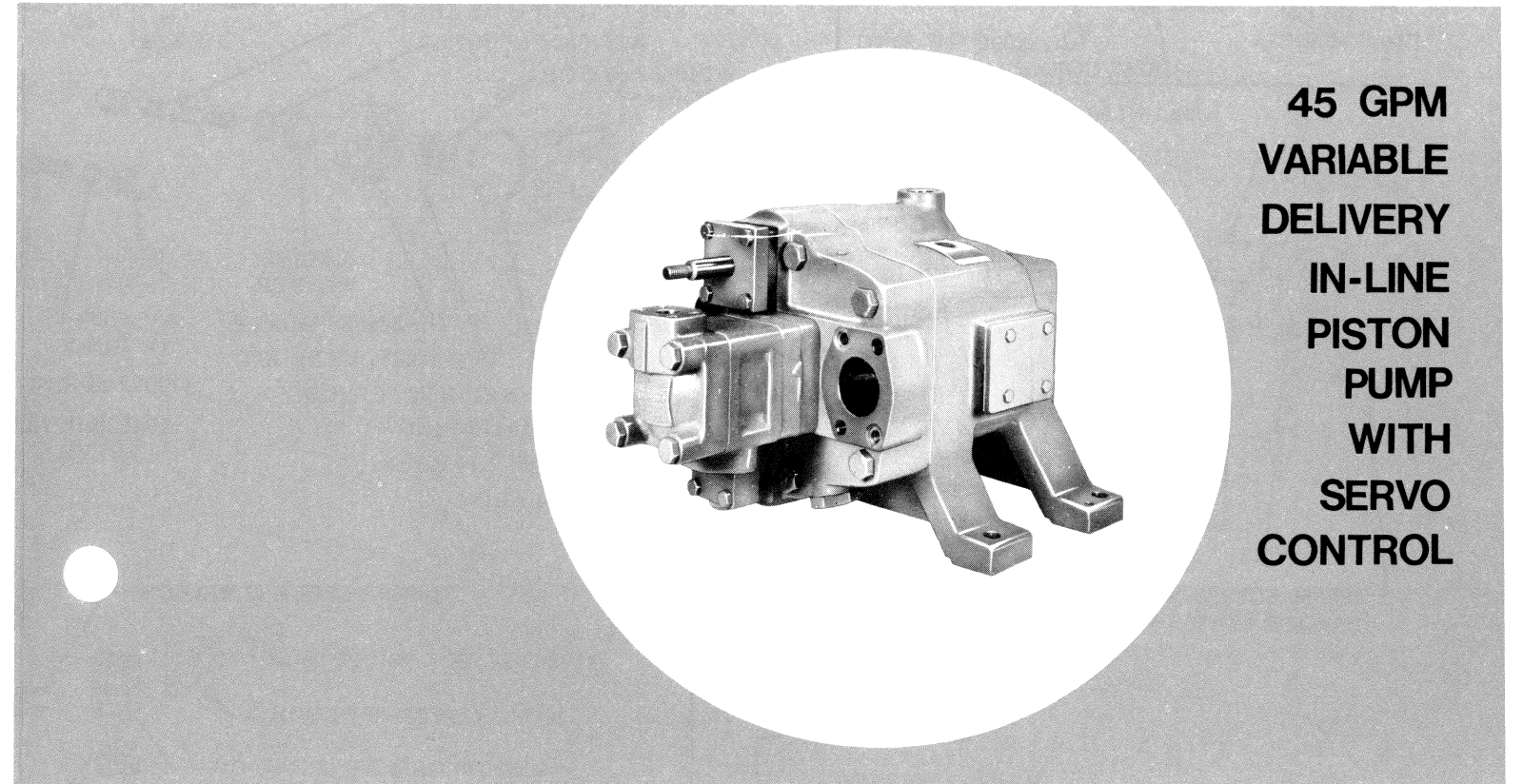
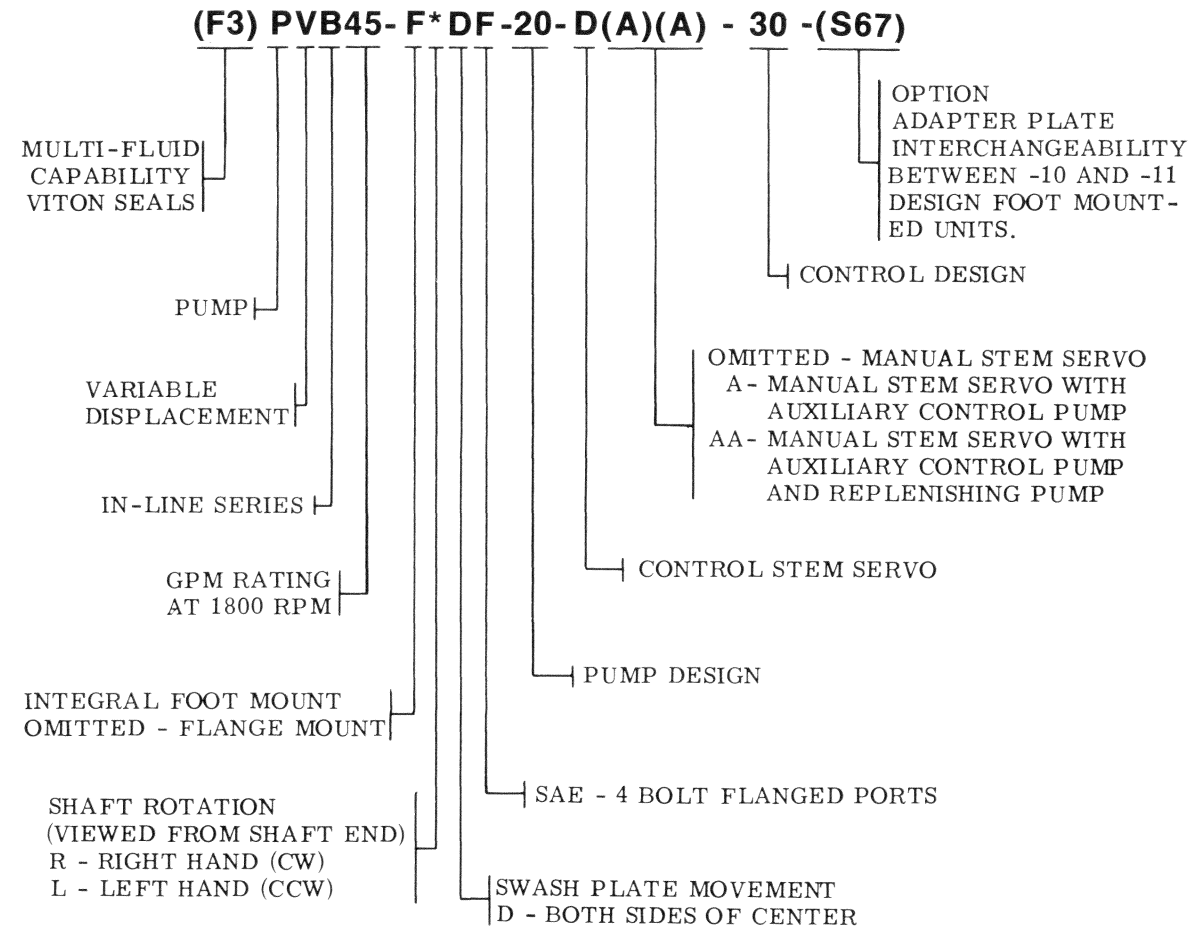

SERVICE PARTS INFORMATION

(F3)-PVB45 - F*DF - 20-D(A)(A)-30- (S67)

To insure sustained efficiency and maximum trouble-free life of this precision equipment, initial and continuous filtration of the fluid medium to 25 microns absolute or less is essential. (For information pertaining to Sperry Vickers economical 3 or 10 micron filters, see installation drawing 522140.)

Litho in U. S. A.

SPERRY VICKERS
TROY, MI. 48084

Revised 5-1-78

I-3274-S

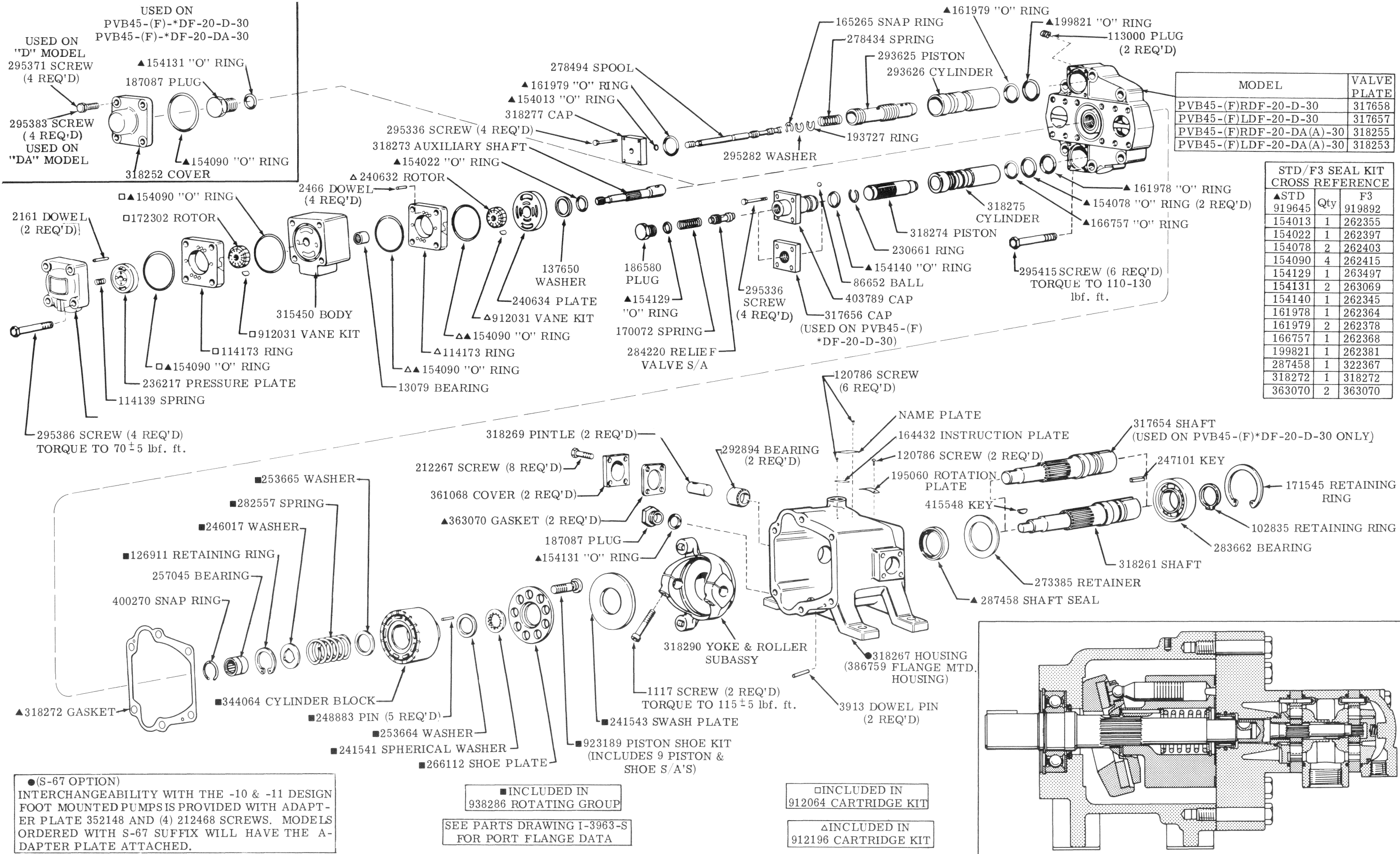

MODEL	VALVE PLATE
PVB45-(F)RDF-20-D-30	317658
PVB45-(F)LDF-20-D-30	317657
PVB45-(F)RDF-20-DA(A)-30	318255
PVB45-(F)LDF-20-DA(A)-30	318253

STD/F3 SEAL KIT CROSS REFERENCE		
▲STD	Qty	F3
919645		919892
154013	1	262355
154022	1	262397
154078	2	262403
154090	4	262415
154129	1	263497
154131	2	263069
154140	1	262345
161978	1	262364
161979	2	262378
166757	1	262368
199821	1	262381
287458	1	322367
318272	1	318272
363070	2	363070

●(S-67 OPTION)
INTERCHANGEABILITY WITH THE -10 & -11 DESIGN FOOT MOUNTED PUMPS IS PROVIDED WITH ADAPTER PLATE 352148 AND (4) 212468 SCREWS. MODELS ORDERED WITH S-67 SUFFIX WILL HAVE THE ADAPTER PLATE ATTACHED.

■ INCLUDED IN 938286 ROTATING GROUP
SEE PARTS DRAWING I-3963-S FOR PORT FLANGE DATA

□ INCLUDED IN 912064 CARTRIDGE KIT
▲ INCLUDED IN 912196 CARTRIDGE KIT

