

MODEL CODE BREAKDOWN

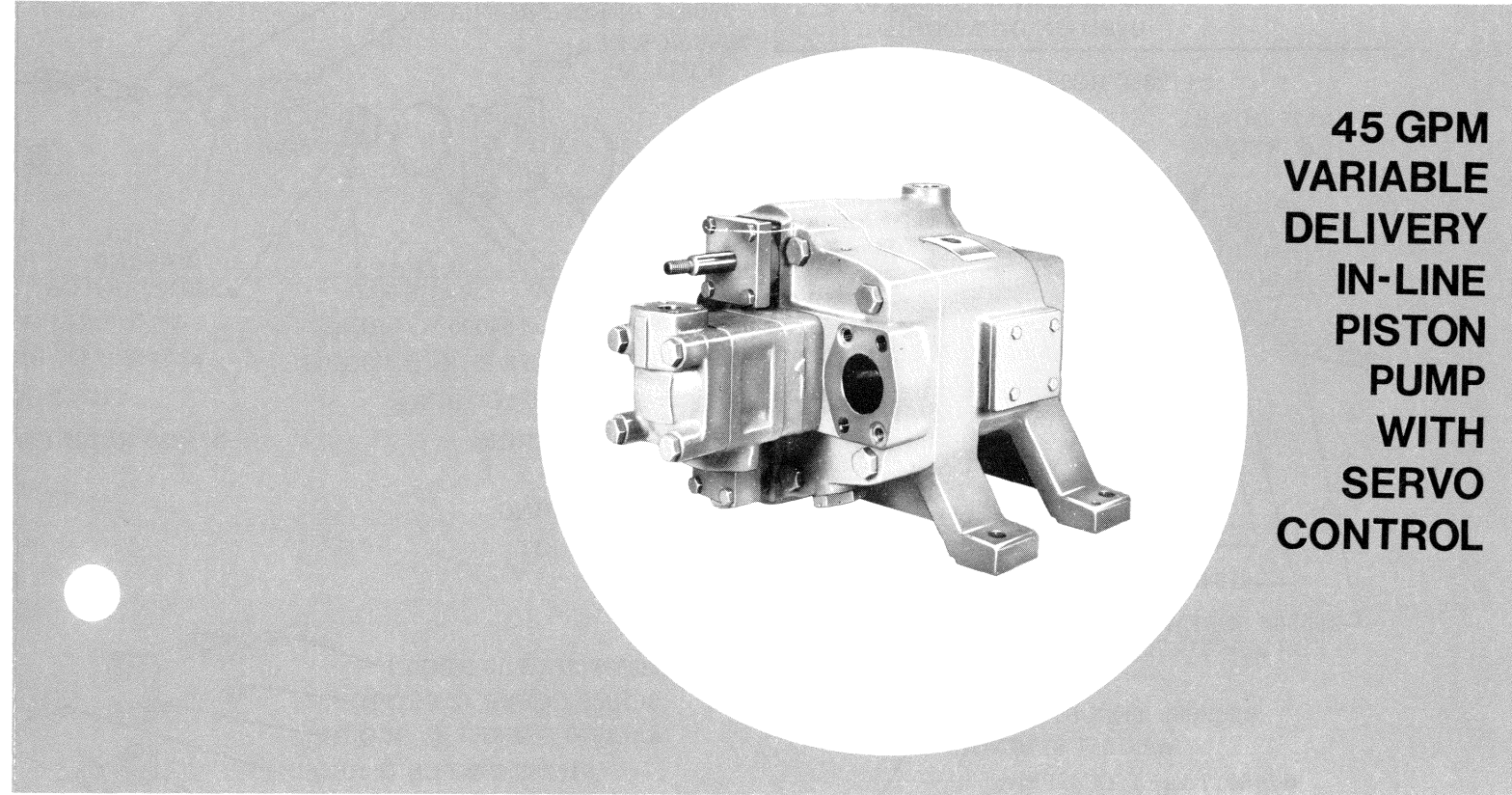
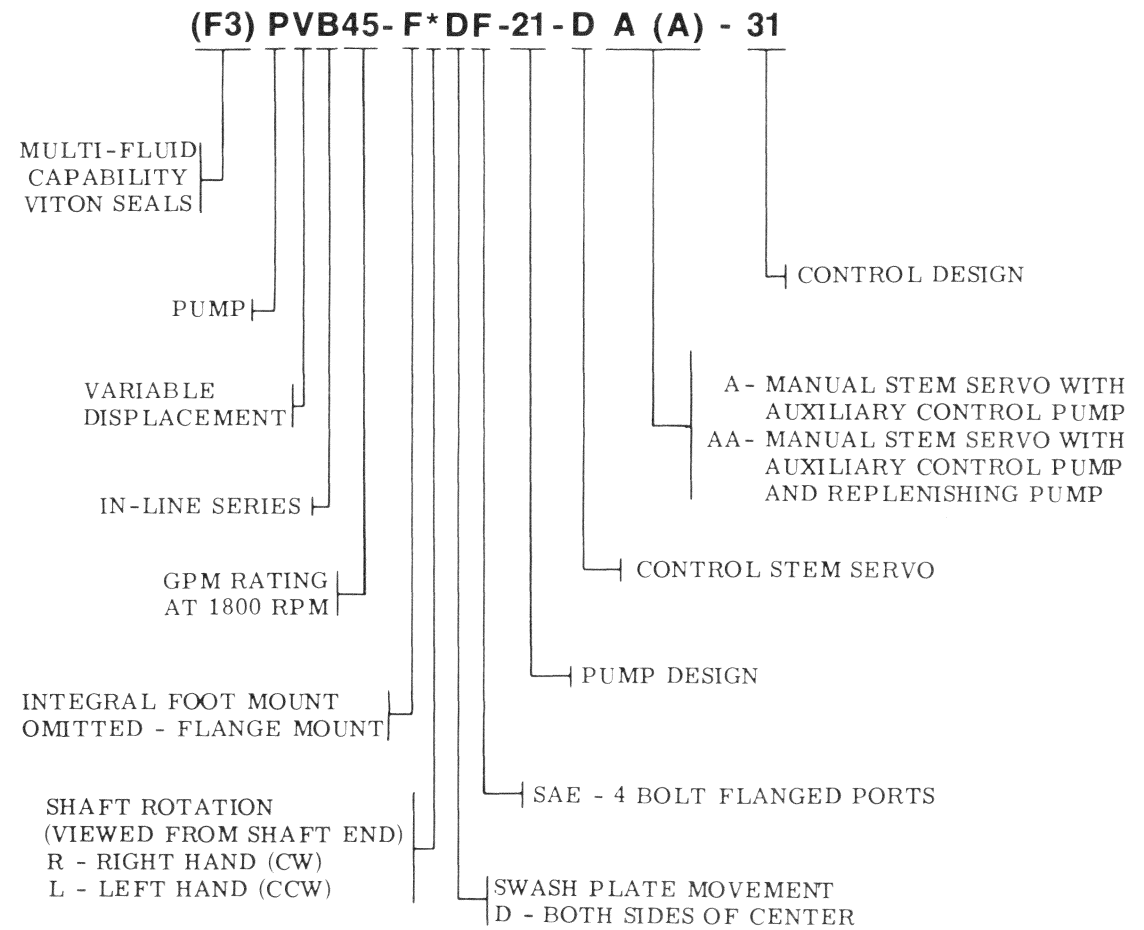

SERVICE PARTS INFORMATION

(F3)PVB45-F*DF-21-DAA-31

To insure sustained efficiency and maximum trouble-free life of this precision equipment, initial and continuous filtration of the fluid medium to 25 microns absolute or less is essential. (For information pertaining to Sperry Vickers economical 3 or 10 micron filters, see installation drawing 522140.)

USED ON PVB45-(F)-*DF-21-DA-31

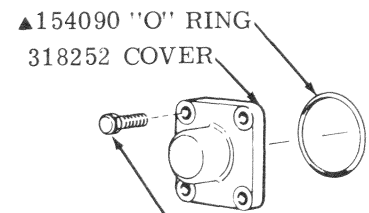

▲154090 "O" RING
318252 COVER

*NOTE: THREAD SHAFT UNTIL BOTTOMED. BACK OFF 1/8 TURN THEN INSTALL COUPLING.

*573726 AUXILIARY SHAFT (SEE NOTE)

▲154022 "O" RING

240634 PRESSURE PLATE

2566 DOWEL (4 REQ'D)

▲912031 VANE KIT

▲▲154090 "O" RING

▲114173 RING (5 USGPM)

▲▲154090 "O" RING

13079 BEARING

315450 BODY

▲154090 "O" RING

912031 VANE KIT

212267 SCREW (8 REQ'D)

361068 COVER (2 REQ'D)

▲363070 GASKET (2 REQ'D)

318269 PINTLE (2 REQ'D)

187087 PLUG

▲154131 "O" RING

344064 CYLINDER BLOCK

▲248883 PIN (5 REQ'D)

▲253664 BACK-UP WASHER

▲241541 SPHERICAL WASHER

▲266112 SHOE PLATE

▲923189 PISTON KIT

▲241543 SWASH PLATE

1117 SCREW (2 REQ'D) TORQUE TO 115 ± 5 lb. ft.

318290 YOKE & ROLLER S/A

278494 SPOOL

▲161979 "O" RING

▲154013 "O" RING

318277 CAP

295336 SCREW (4 REQ'D) TORQUE TO 30 ± 5 lb. ft.

▲154022 "O" RING

240634 PRESSURE PLATE

2566 DOWEL (4 REQ'D)

▲912031 VANE KIT

▲▲154090 "O" RING

▲114173 RING (5 USGPM)

▲▲154090 "O" RING

13079 BEARING

315450 BODY

▲154090 "O" RING

912031 VANE KIT

212267 SCREW (8 REQ'D)

361068 COVER (2 REQ'D)

▲363070 GASKET (2 REQ'D)

318269 PINTLE (2 REQ'D)

187087 PLUG

▲154131 "O" RING

344064 CYLINDER BLOCK

▲248883 PIN (5 REQ'D)

▲253664 BACK-UP WASHER

▲241541 SPHERICAL WASHER

▲266112 SHOE PLATE

▲923189 PISTON KIT

▲241543 SWASH PLATE

1117 SCREW (2 REQ'D) TORQUE TO 115 ± 5 lb. ft.

318290 YOKE & ROLLER S/A

137650 WASHER

▲240632 ROTOR

186580 PLUG

▲154129 "O" RING

170072 SPRING

284220 RELIEF VALVE S/A

292894 BEARING (2 REQ'D)

120786 SCREW (6 REQ'D)

NAMEPLATE

164432 INSTRUCTION PLATE

120786 SCREW (2 REQ'D)

195060 ROTATION PLATE

247101 KEY

283662 BEARING

102835 RETAINING RING

171545 RETAINING RING

573725 SHAFT

273385 RETAINER

▲287458 SHAFT SEAL

318267 HOUSING (387826 FLANGE MTD. HOUSING)

3913 DOWEL PIN (2 REQ'D)

318267 HOUSING (387826 FLANGE MTD. HOUSING)

3913 DOWEL PIN (2 REQ'D)

318267 HOUSING (387826 FLANGE MTD. HOUSING)

3913 DOWEL PIN (2 REQ'D)

318267 HOUSING (387826 FLANGE MTD. HOUSING)

3913 DOWEL PIN (2 REQ'D)

318267 HOUSING (387826 FLANGE MTD. HOUSING)

3913 DOWEL PIN (2 REQ'D)

318267 HOUSING (387826 FLANGE MTD. HOUSING)

3913 DOWEL PIN (2 REQ'D)

318267 HOUSING (387826 FLANGE MTD. HOUSING)

3913 DOWEL PIN (2 REQ'D)

295282 WASHER

193727 RING

278434 SPRING

293625 PISTON

293626 CYLINDER

113000 PLUG (2 REQ'D)

▲161979 "O" RING

▲199821 "O" RING

VALVE PLATE (SEE TABLE)

416661 COUPLING

▲161978 "O" RING

▲154078 "O" RING (2 REQ'D)

▲161757 "O" RING

318275 CYLINDER

295415 SCREW (6 REQ'D) TORQUE TO 110-130 lb. ft.

295336 SCREW (4 REQ'D) TORQUE TO 30 ± 5 lb. ft.

165265 SNAP RING

318274 PISTON

230661 RETAINING RING

▲154140 "O" RING

86652 BALL

403789 CAP

295336 SCREW (4 REQ'D) TORQUE TO 30 ± 5 lb. ft.

292894 BEARING (2 REQ'D)

120786 SCREW (6 REQ'D)

NAMEPLATE

164432 INSTRUCTION PLATE

120786 SCREW (2 REQ'D)

195060 ROTATION PLATE

247101 KEY

283662 BEARING

102835 RETAINING RING

171545 RETAINING RING

573725 SHAFT

273385 RETAINER

▲287458 SHAFT SEAL

318267 HOUSING (387826 FLANGE MTD. HOUSING)

3913 DOWEL PIN (2 REQ'D)

318267 HOUSING (387826 FLANGE MTD. HOUSING)

3913 DOWEL PIN (2 REQ'D)

318267 HOUSING (387826 FLANGE MTD. HOUSING)

3913 DOWEL PIN (2 REQ'D)

318267 HOUSING (387826 FLANGE MTD. HOUSING)

3913 DOWEL PIN (2 REQ'D)

318267 HOUSING (387826 FLANGE MTD. HOUSING)

3913 DOWEL PIN (2 REQ'D)

VALVE PLATE	MODEL
318255	PVB45-(F)RDF-21-DA(A)-31
318253	PVB45-(F)LDF-21-DA(A)-31

▲INCLUDED IN 919645 SEAL KIT

F3 EQUIVALENT SEAL KIT 919892

■ INCLUDED IN 938286 ROTATING GROUP

SEE PARTS DRAWING I-3963-S FOR PORT FLANGE DATA

□ INCLUDED IN 912064 CARTRIDGE KIT

▲ INCLUDED IN 912196 CARTRIDGE KIT

