

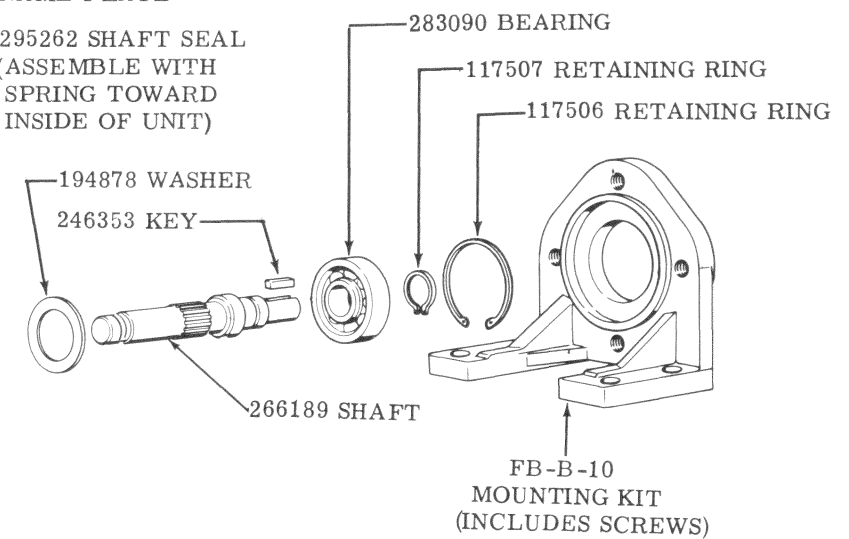

MODEL	VALVE PLATE SUB-ASSY (INCLUDES: ROTATION PLATE & 251108 BEARING)
PFB20-L-10	938382
PFB20-R-10	938381
MFB20-U-10	938383
MFB29-U-10	941952

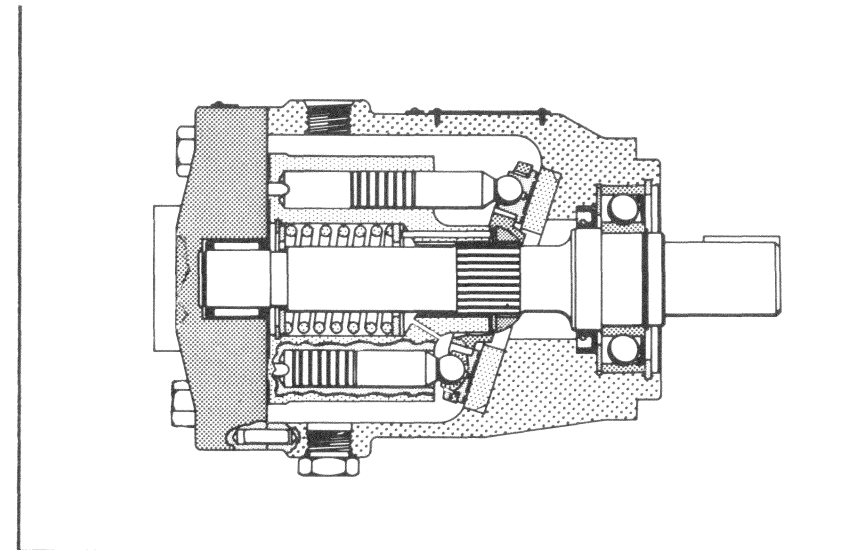
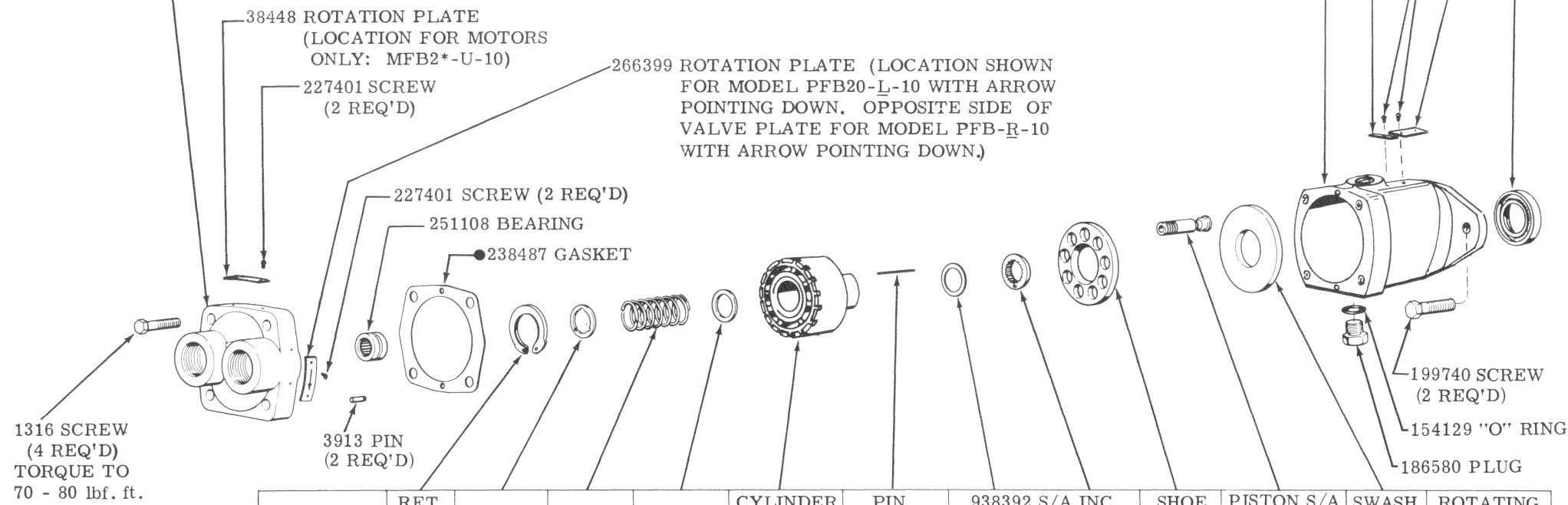

MODEL	RET. RING	WASHER	SPRING	WASHER	CYLINDER BLOCK	PIN (3 REQ'D)	938392 S/A INC.		SHOE PLATE	PISTON S/A KIT	SWASH PLATE	ROTATING GROUP KIT
							WASHER	WASHER				
THESE PARTS INCLUDED IN												
PFB20-L-10	194025	244931	246386	238780	250688	248835	238836	283993	248609	941883	239335	938280
PFB20-R-10			284197		941884					938281		
MFB20-U-10			287454		941885					938295		
MFB29-U-10												

F3 EQUIVALENT  
SEAL KIT 919313

● INCLUDED IN  
GASKET KIT 919242