

**MODEL CODE BREAKDOWN**

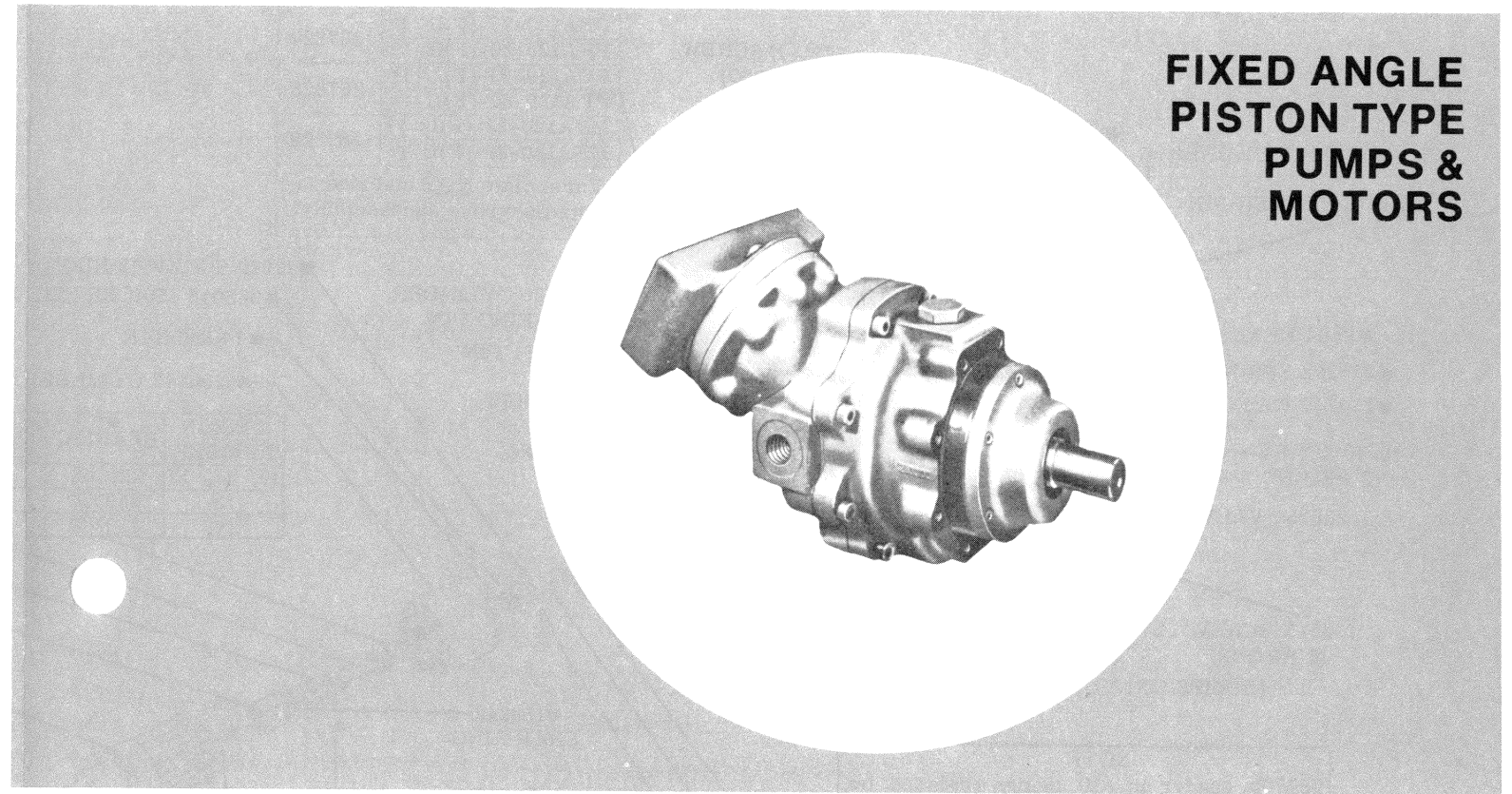
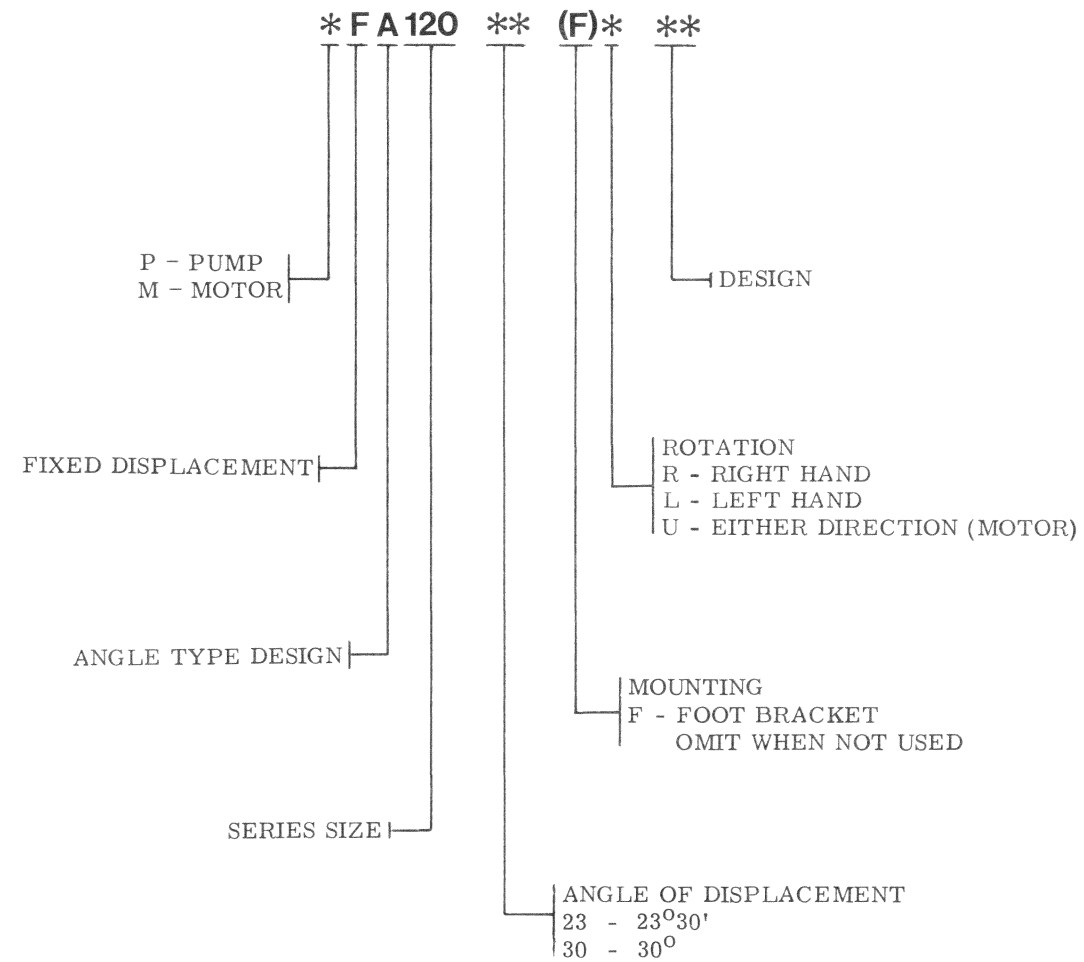

**FIXED ANGLE  
PISTON TYPE  
PUMPS &  
MOTORS**

**SERVICE  
PARTS  
INFORMATION**

**PFA120-\*\*- (F) \*-10/11/12/13/14**  
**MFA120-\*\*- (F) \*-10/11/12/13/14**

To insure sustained efficiency and maximum trouble-free life of this precision equipment, initial and continuous filtration of the fluid medium to 25 microns absolute or less is essential. (For information pertaining to Sperry Vickers economical 3 or 10 micron filters, see installation drawing 522140.)

Litho in U. S. A.

SPERRY VICKERS  
TROY, MI. 48084

Revised 8-1-79

I-3221-S

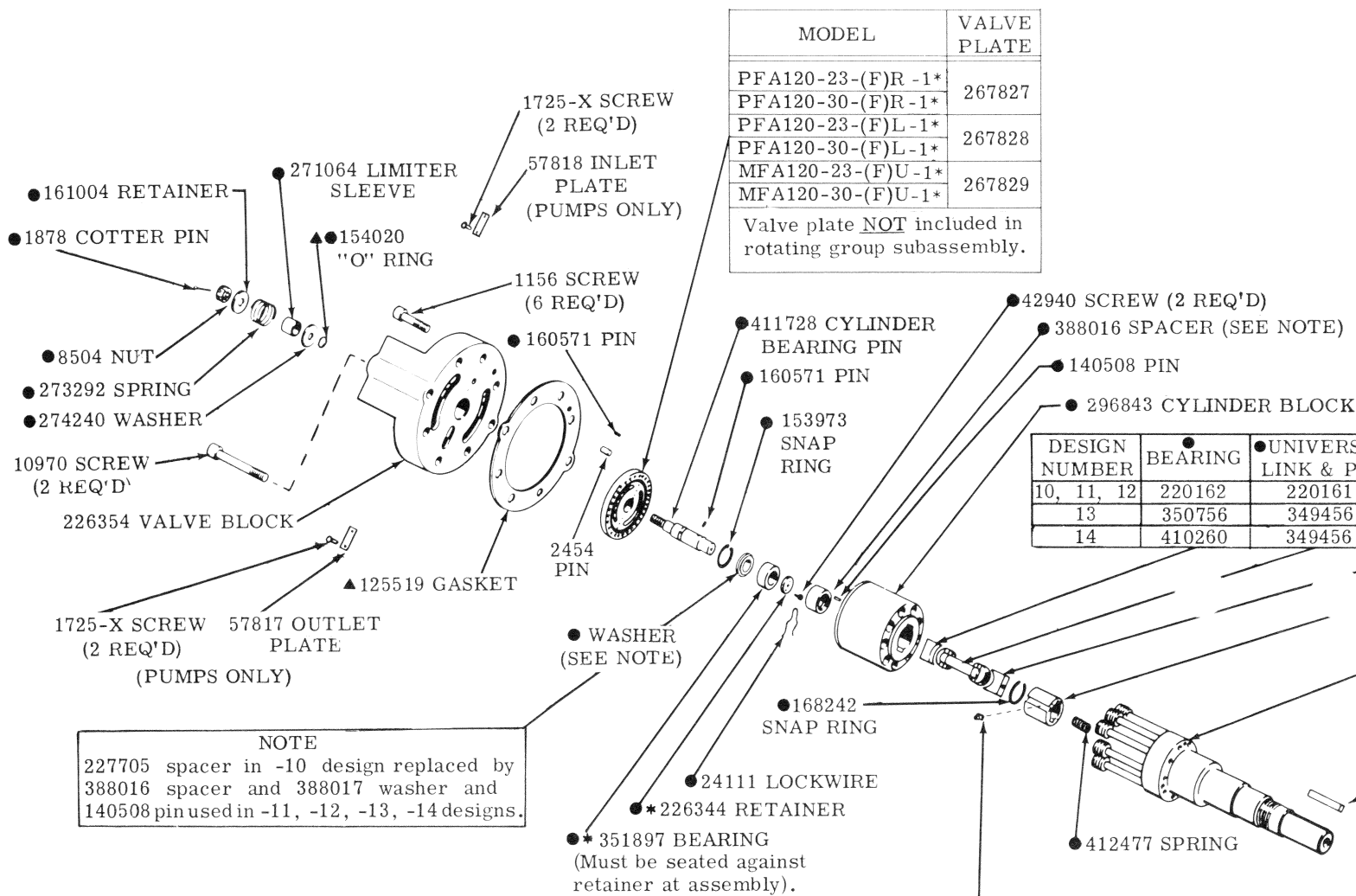

MODEL	VALVE PLATE
PFA120-23-(F)R -1*	267827
PFA120-30-(F)R -1*	267827
PFA120-23-(F)L -1*	267828
PFA120-30-(F)L -1*	267828
MFA120-23-(F)U -1*	267829
MFA120-30-(F)U -1*	267829

Valve plate **NOT** included in rotating group subassembly.

DESIGN NUMBER	BEARING	UNIVERSAL LINK & PIN	BEARING	RETAINER	SHAFT SUB-ASSY	ROTATING GROUP
10, 11, 12	220162	220161	220162	220163	226033	938070
13	350756	349456	341841	341842	344755	
14	410260	349456	341841	388015	344755	

**NOTE**  
227705 spacer in -10 design replaced by 388016 spacer and 388017 washer and 140508 pin used in -11, -12, -13, -14 designs.

CONNECTION FLANGE MODEL NUMBERS		PIPING SIZE	FLANGE DESIGN
WELDED	THREADED		
FL-20-WS-20	FL-20-PS-20	2-1/2"	STRAIGHT
FL-20-WL-20	FL-20-PL-20	2-1/2"	ELL
FL-24-WS-20	FL-24-PS-20	3"	STRAIGHT
FL-24-WL-30	FL-24-PL-20	3"	ELL

FLANGE ASSEMBLY INCLUDES: FLANGE (1), "O" RING (1), SCREWS (4) AND WASHERS (4)

Flanges tabulated above are rated for 3000 PSI. Straight flanges with SAE Grade 8 screws for use to 5000 PSI can be supplied. Specify by adding "HP" to model number. Example: FL-20-WS-HP-20. Torque "HP" flange screws to 175-200 Ft. Lbs.

MODEL	ANGLE HOUSING
PFA120-23-(F)R -1*	249839
PFA120-23-(F)L -1*	
MFA120-23-(F)U -1*	237237
PFA120-30-(F)R -1*	
MFA120-30-(F)U -1*	

● INCLUDED IN ROTATING GROUP SUBASSEMBLY

▲ INCLUDED IN 919189 SEAL KIT

\*227359 BEARING MUST SEAT AGAINST RETAINER WHEN ASSEMBLED.

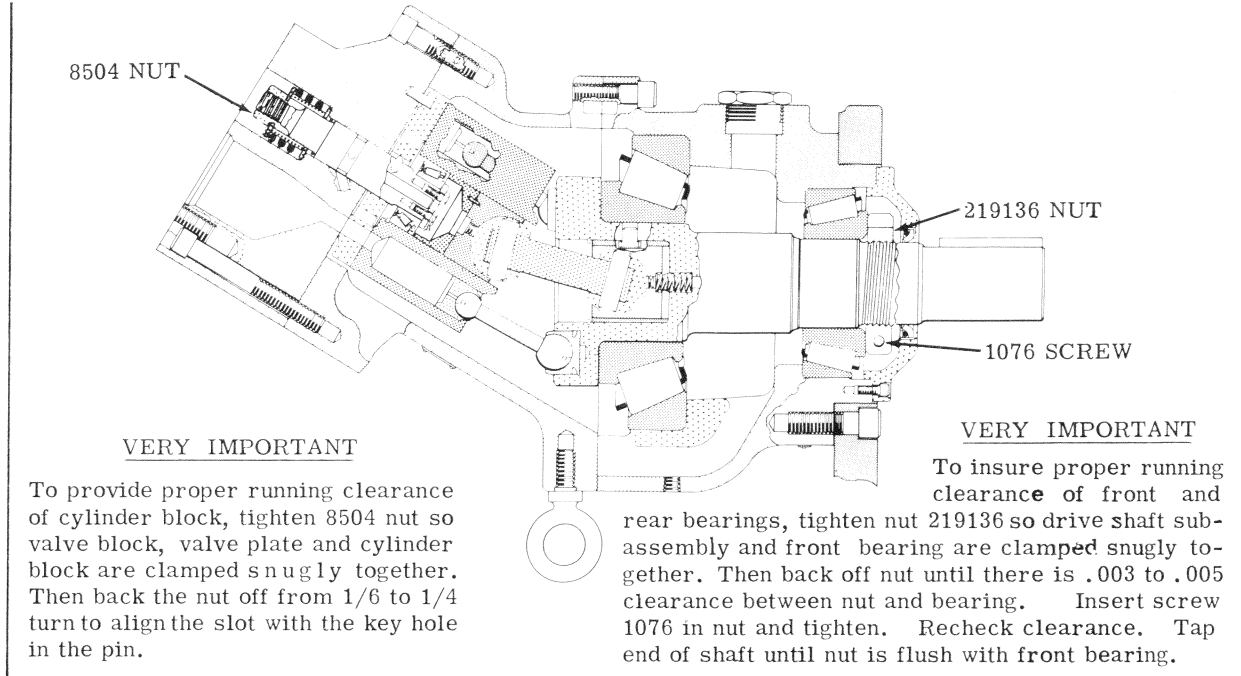

-14 DESIGN FACE TYPE SHAFT SEAL S/A PARTS INCLUDED IN 942319.

**DRAIN CONNECTION INSTRUCTIONS**  
Any one of three drain connections may be used. A full size unrestricted case drain line must be connected from the drain port directly to reservoir in such a manner that the housing remains filled with fluid. Drain line loop must extend above top of case and terminate below fluid level in reservoir, to prevent syphoning action.

181822 PLUG (2 REQ'D) For unused drain ports.  
▲154133 SEAL (2 REQ'D)

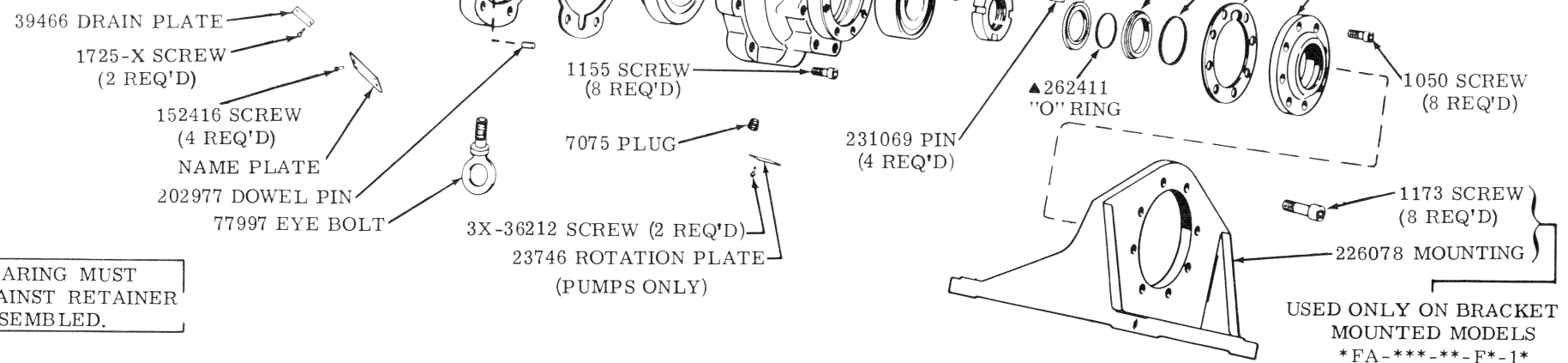

USED ONLY ON BRACKET MOUNTED MODELS \*FA-\*\*\*-\*\*\*-F\*-1\*