

MODEL CODE BREAKDOWN

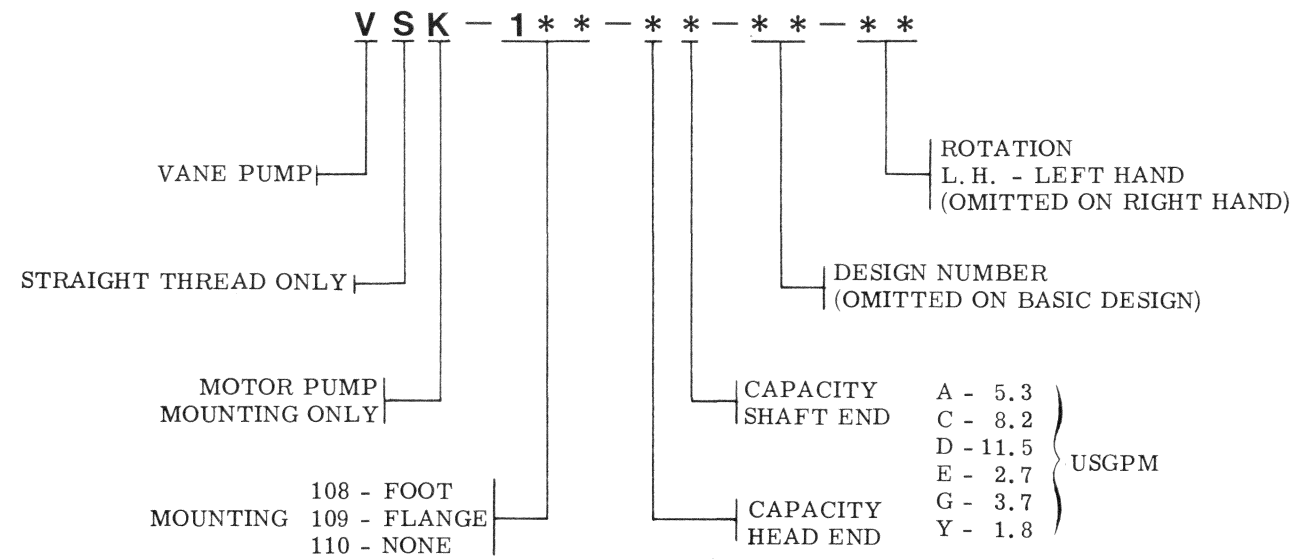

SEE SERVICE MANUAL
I-1425-S FOR
MAINTENANCE INFORMATION

CARTRIDGE ASSEMBLY
VIEW FACING HEAD END

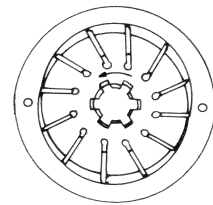

Assembly of the rotor and vanes is determined by the direction of pump shaft rotation. Vanes must be assembled so that the small beveled edges are trailing as shown for right hand rotation. Rotation is determined by viewing pump from shaft end.

To insure sustained efficiency and maximum trouble-free life of this precision equipment, initial and continuous filtration of the fluid medium to 25 microns absolute or less is essential. (For information pertaining to Sperry Vickers economical 3 or 10 micron filters, see installation drawing 522140.)

Litho in U. S. A.

SPERRY VICKERS

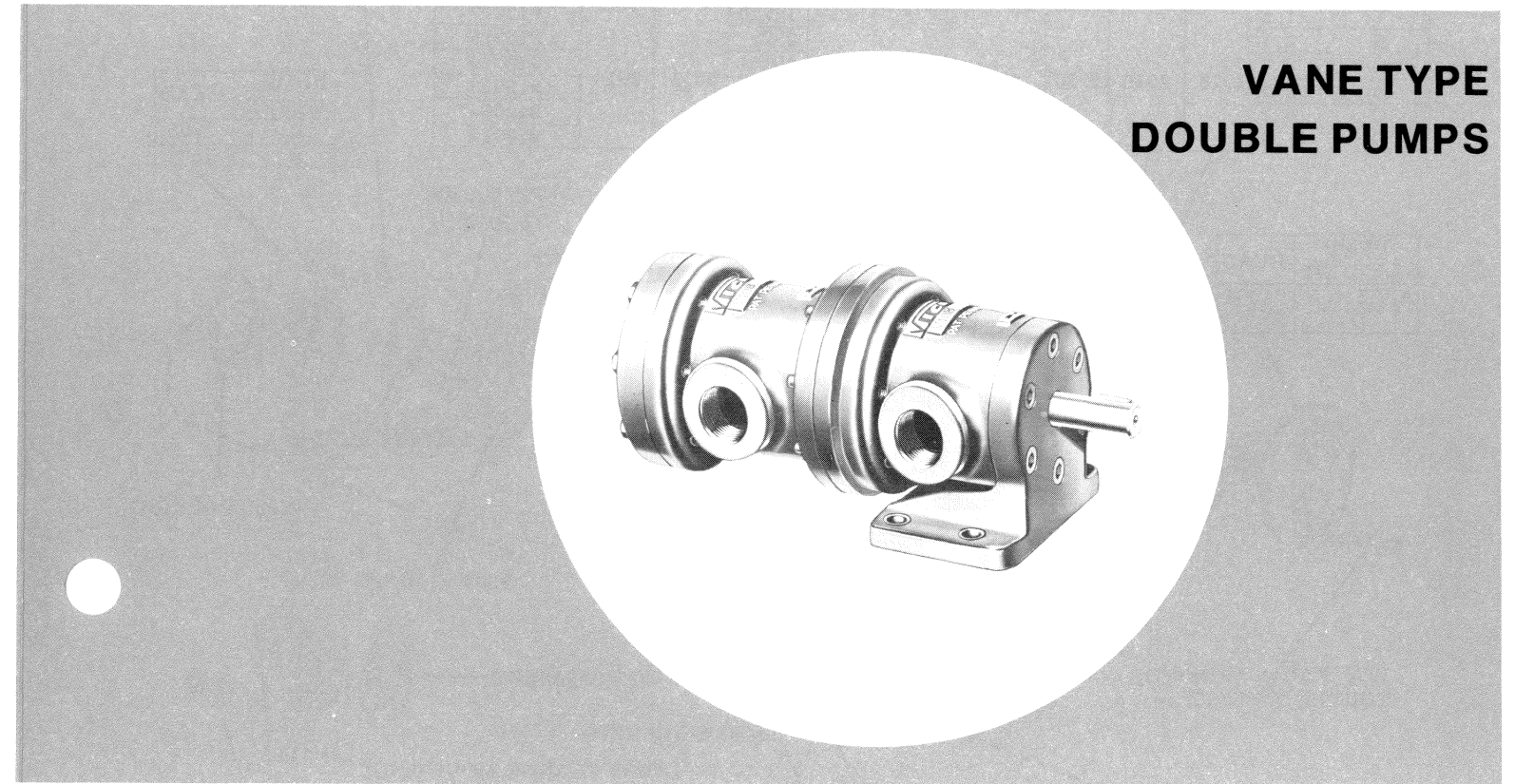

SERVICE PARTS INFORMATION

Small Series

V, VK, VS, VSK-108, 109, 110-* -10

SPERRY VICKERS
TROY, MI. 48084

Revised 3-1-79

I-1801-S

WARNING: USE THIS DRAWING FOR PARTS INFORMATION ONLY.

-10 DESIGN

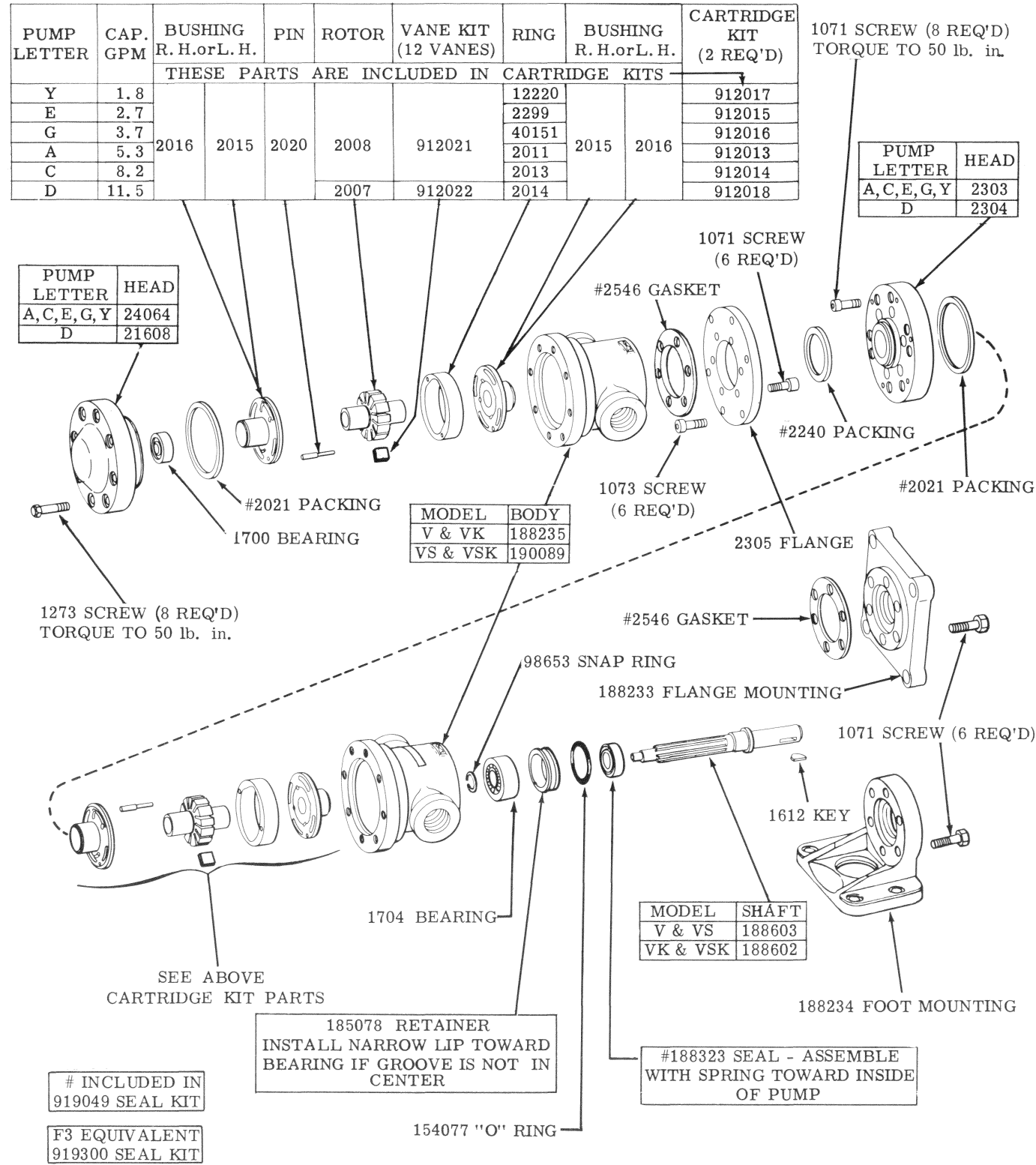

SEE OVERHAUL MANUAL I-3100-S FOR MAINTENANCE INFORMATION

BASIC DESIGN

