

MODEL CODE BREAKDOWN

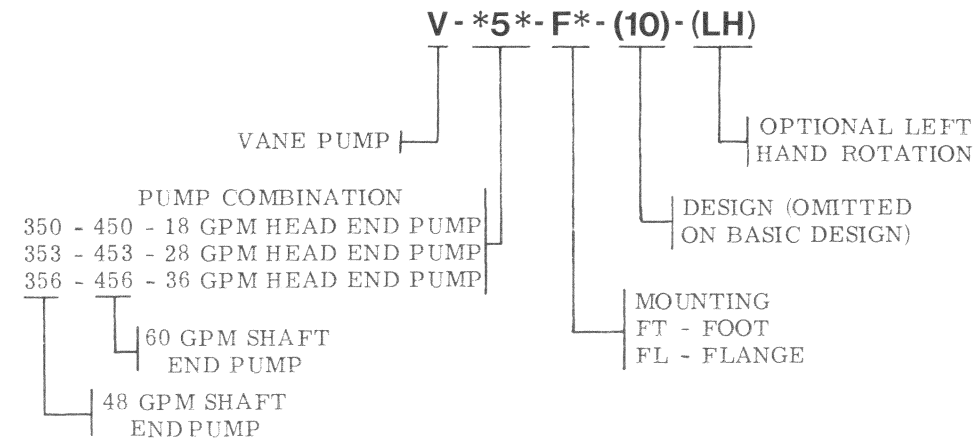

ROTOR & VANE ASSEMBLY
VIEW FROM HEAD END

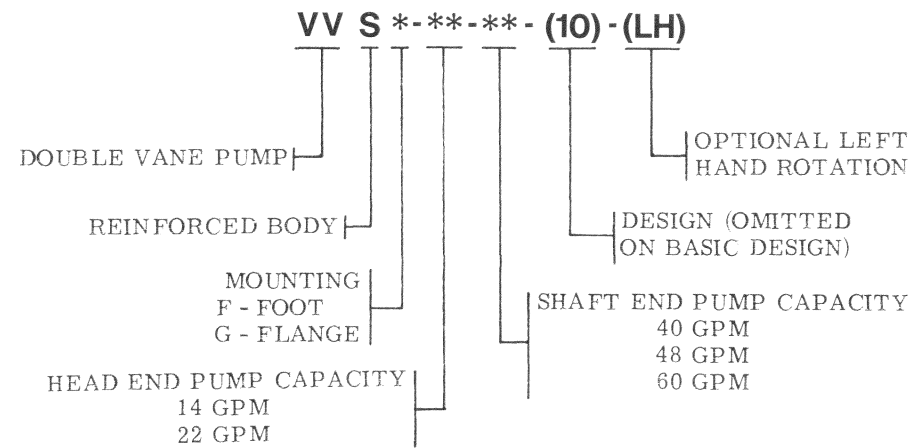
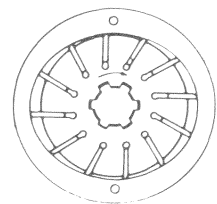

L. H. ROTATION

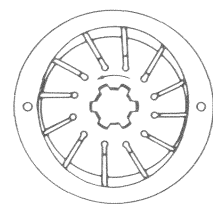

R. H. ROTATION

Assembly of the rotor and vanes is determined by the direction of pump shaft rotation. Vanes must be assembled so that the small beveled edges are trailing as shown.

For satisfactory service life of these components, use full flow filtration to provide fluid which meets ISO cleanliness code 18/15 or cleaner. Selections from Vickers OFP, OFR, and OFRS series are recommended.

Litho in U. S. A.



Service Parts Information

Vane
Type
Double
Pumps

VVS*-**-*-(10)-(LH)
V-35*-F*-(10)-(LH)
V-45*-F*-(10)-(LH)

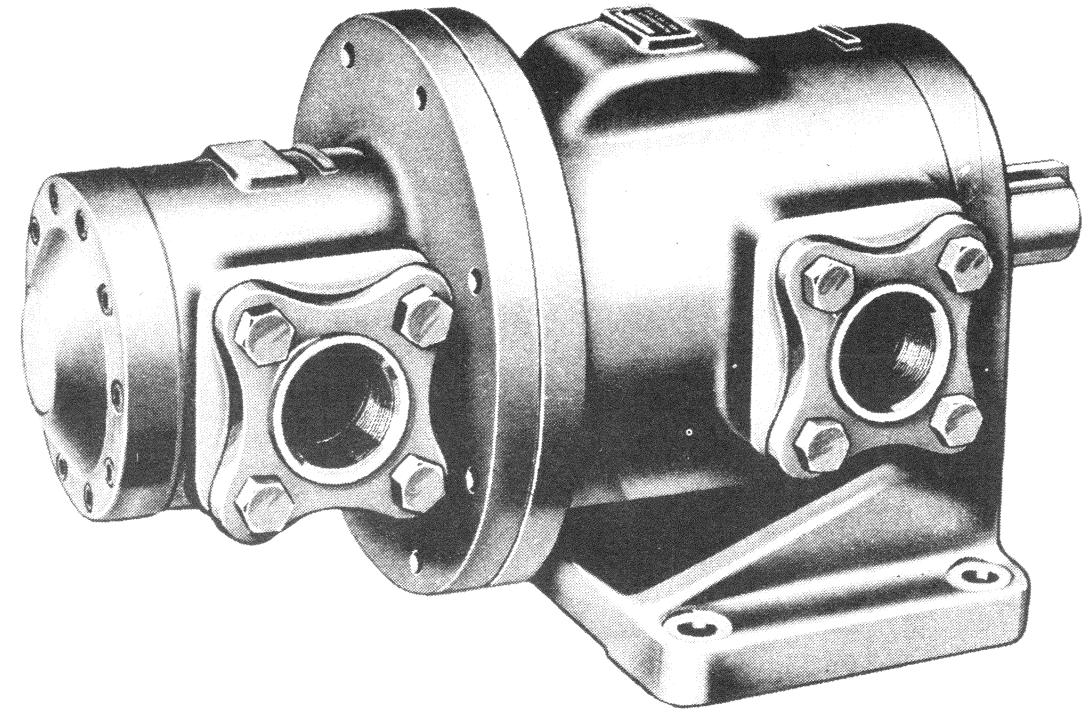

Vickers, Incorporated

1401 Crooks Road
Troy, Michigan 48084

Revised 10-1-85

I-1697-S

DOUBLE PUMPS VANE TYPE
Intermediate Size Pump Coupled to Large Pump

MODELS	GASKET	MOUNTING	WASHER (8 REQ'D)	SCREW (8 REQ'D)
VVSE-*	—	* 6041	—	—
V-***-FT	—	FOOT	—	1153
VVSG-*	32859	9323	8545	—
V-***-FL	—	FLANGE	—	—

OUTLET FLANGE	△ GASKET or "O" RING	BODY	PLUG	△ GASKET or "O" RING	INLET FLANGE	△ SEAL	△ GASKET or "O" RING	OUTLET FLANGE	GREASE FITTING	BODY	△ SEAL	SHAFT	COVER	DESIGN
9227	27237 GASKET	1566-X	7074	27238 GASKET	20862	3694	27237 GASKET	9227	3X-31645	6039	3695	21597	6047	BASIC (No Suffix)
184443	154034 "O" RING	184829	—	154038 "O" RING	184442	—	154034 "O" RING	184443	—	183932	56013	184651	122089	-10

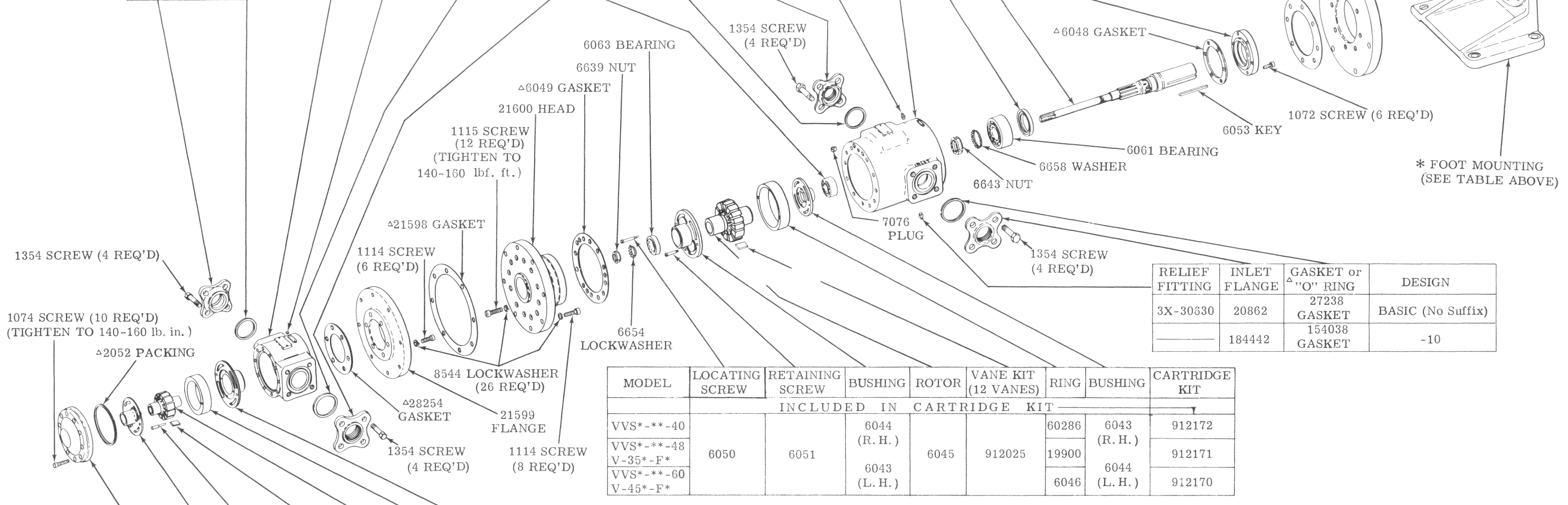

RELIEF FITTING	INLET FLANGE	GASKET or △ "O" RING	DESIGN
3X-30630	20862	27238 GASKET	BASIC (No Suffix)
—	184442	154038 GASKET	-10

MODEL	LOCATING SCREW	RETAINING SCREW	BUSHING	ROTOR	VANE KIT (12 VANES)	RING	BUSHING	CARTRIDGE KIT
INCLUDED IN CARTRIDGE KIT								
VVS*-**-40			6044 (R. H.)			60286	6043 (R. H.)	912172
VVS*-**-48	6050	6051		6045	912025	19900		912171
V-35*-F*			6043 (L. H.)			6046	6044 (L. H.)	912170

MODEL	HEAD	BUSHING	PIN	VANE KIT (12 VANES)	ROTOR	RING	BUSHING	CARTRIDGE KIT
INCLUDED IN CARTRIDGE KIT								
VVS*-14-**						24188		919093
V-350, V-450	5572	222046 (R. H.)	2051	912029	36172	2044	222045 (R. H.)	919095
VVS*-22-**						15482		912084
V-353, V-453		222045 (L. H.)				2347	222046 (L. H.)	912085
V-356, V-456	1568-X			912028	34524	3246		912086

MODEL	△SEAL KIT
-DESIGN	912096
-10 DESIGN	919030
-10 DESIGN	F3 EQUIVALENT 919254