

Service Parts Information



**HIGH TORQUE
LOW SPEED
VANE MOTORS**

MHT-1000-*1-30-S30

MODEL	SHAFT	SNAP RING	KEY	BEARING	PLUG	RING
MHT-1000-R1-30-S30	390616	354386	332265	310539	7074 (1)	343826
MHT-1000-N1-30-S30	—	—	—	—	—	—

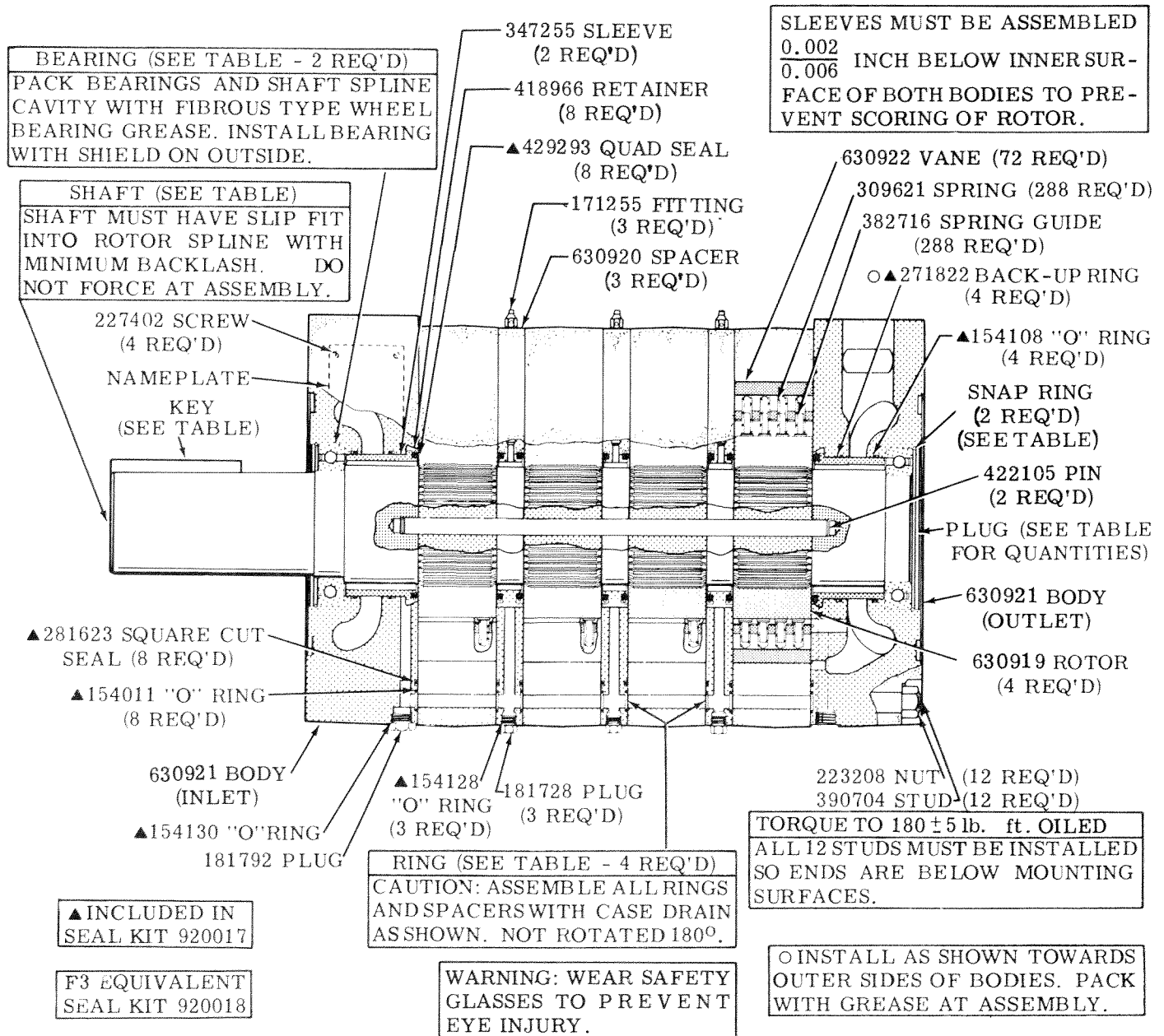

MODEL CODE BREAKDOWN

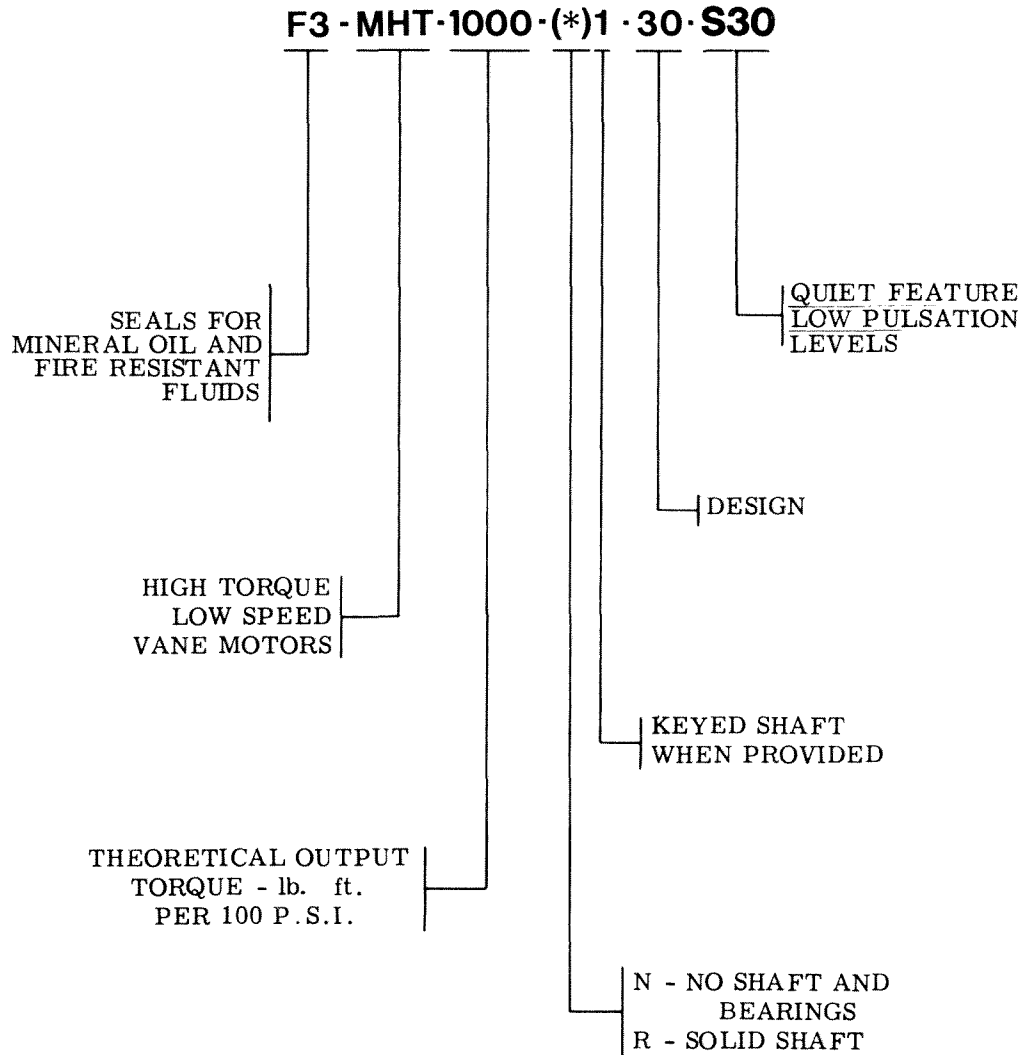

For satisfactory service life of these components, use full flow filtration to provide fluid which meets ISO cleanliness code 18/15 or cleaner. Selections from Vickers OFP, OFR, and OFRS series are recommended.