

Service Parts Information

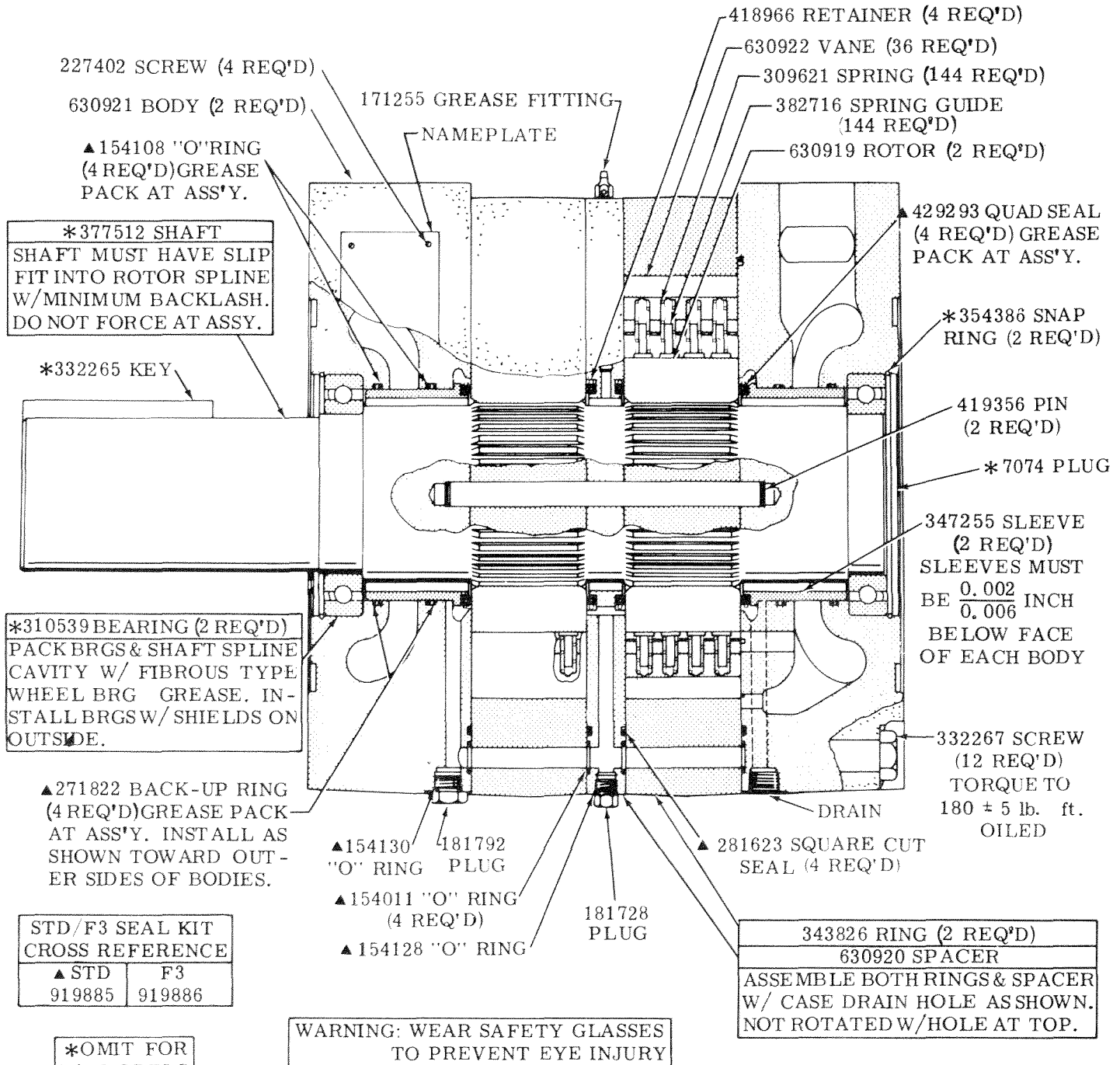

**HIGH TORQUE
LOW SPEED
VANE MOTORS**

MHT-500-*1-30-S30



CAUTION: WHEN ASSEMBLING CARTRIDGE, INSERT VANES IN ROTOR SLOTS AT THE MINOR DIAMETER OF CAM RING. ROTATE CARTRIDGE ONE COMPLETE REVOLUTION PRIOR TO ASSEMBLY WITH BODIES. THIS PREVENTS MISALIGNMENT OF SPRINGS AND GUIDES. MAKE SURE THE MARKED ROTOR TOOTH OF EACH CARTRIDGE IS IN LINE BEFORE INSTALLATION OF SHAFT.

MODEL CODE BREAKDOWN

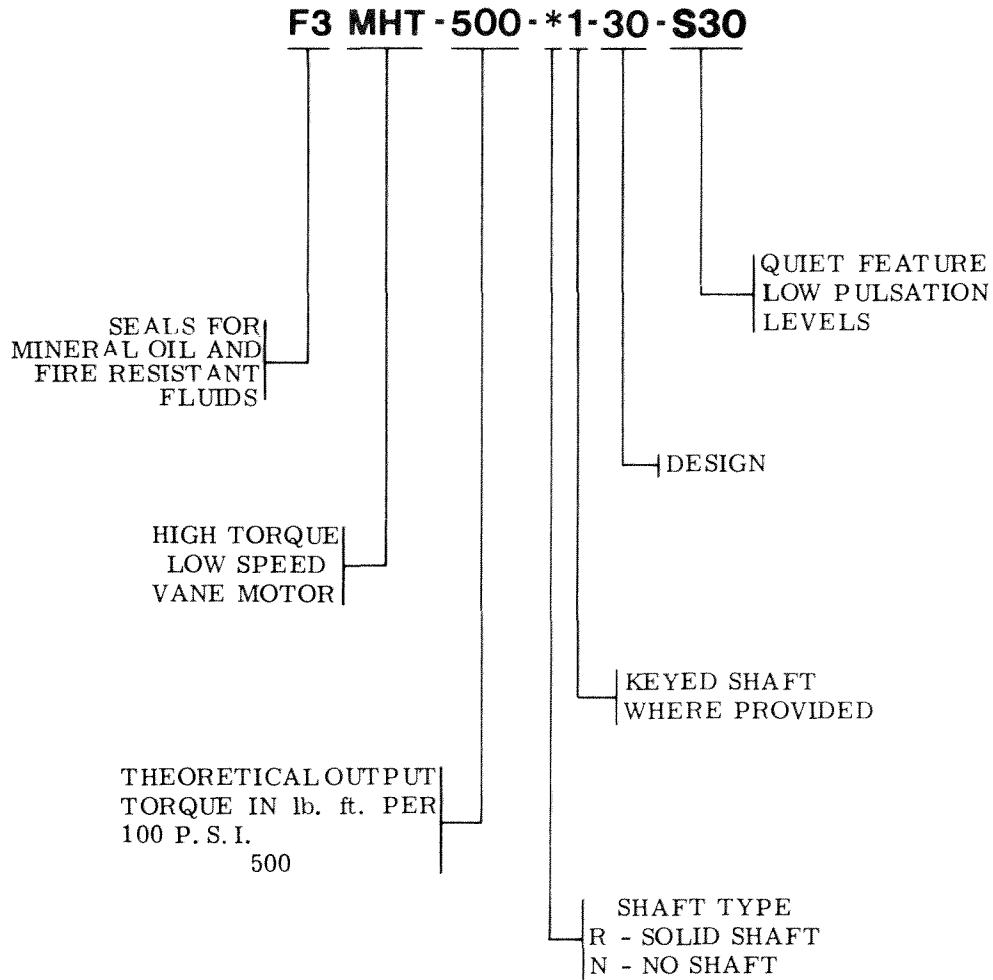

For satisfactory service life of these components, use full flow filtration to provide fluid which meets ISO cleanliness code 18/15 or cleaner. Selections from Vickers OFP, OFR, and OFRS series are recommended.