

Service Parts Information



**HIGH TORQUE
LOW SPEED
VANE MOTORS**

MHT-250-*1-30-S30

STD/F3 SEAL KIT CROSS REFERENCE	
▲ STD 919873	F3 919874

MODEL	SHAFT	SNAP RING	KEY	BEARING	PLUG	RING
MHT-250-N1-30-S30	_____	_____	_____	_____	_____	343826
MHT-250-R1-30-S30	345769	354386	306439	310539	7074	

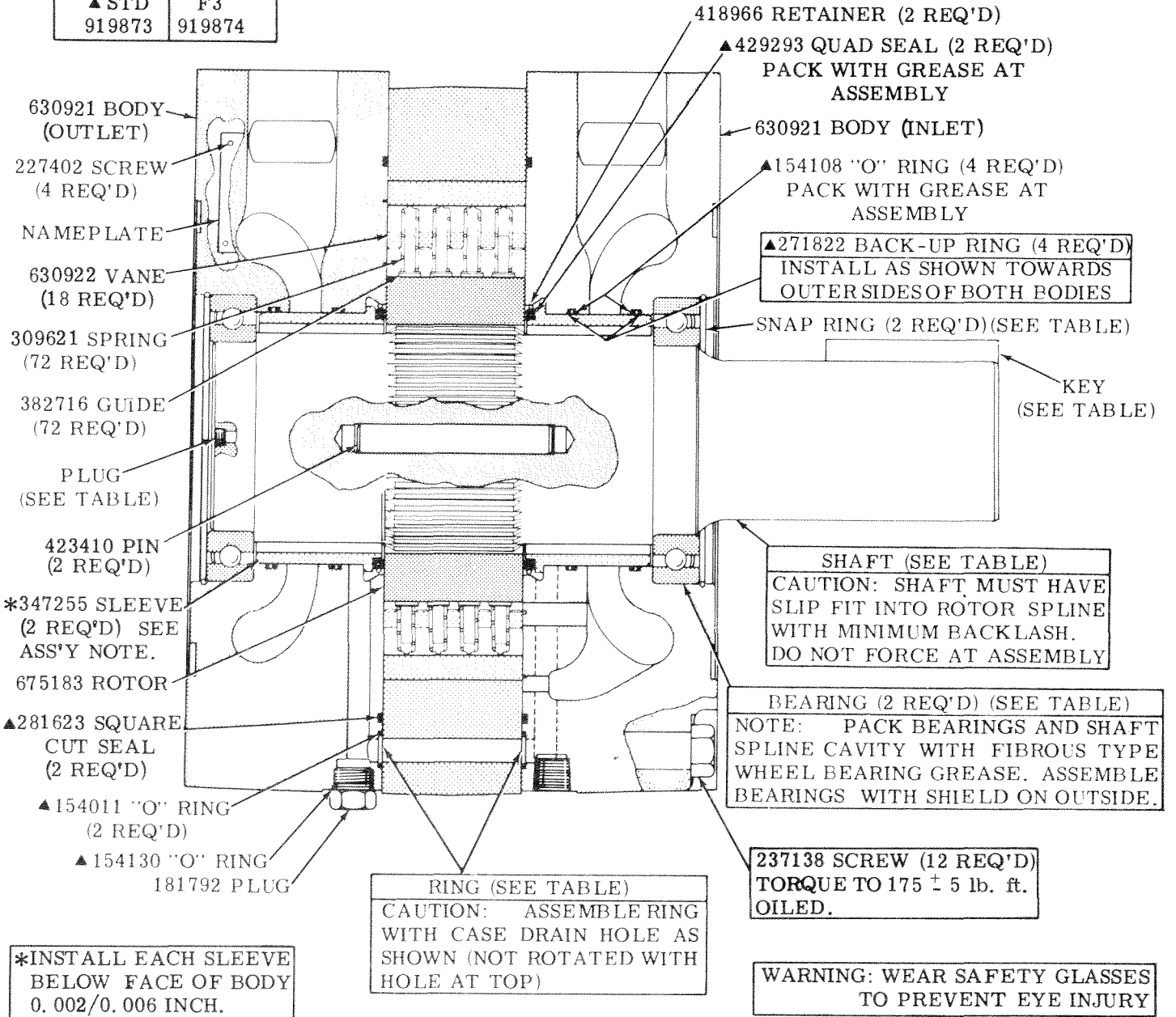

CAUTION: WHEN ASSEMBLING CARTRIDGE, INSERT VANES IN ROTOR SLOTS AT THE MINOR DIAMETER OF CAM RING. ROTATE CARTRIDGE ONE COMPLETE REVOLUTION PRIOR TO ASSEMBLY WITH BODIES. THIS PREVENTS MISALIGNMENT OF SPRINGS AND GUIDES.

MODEL CODE BREAKDOWN

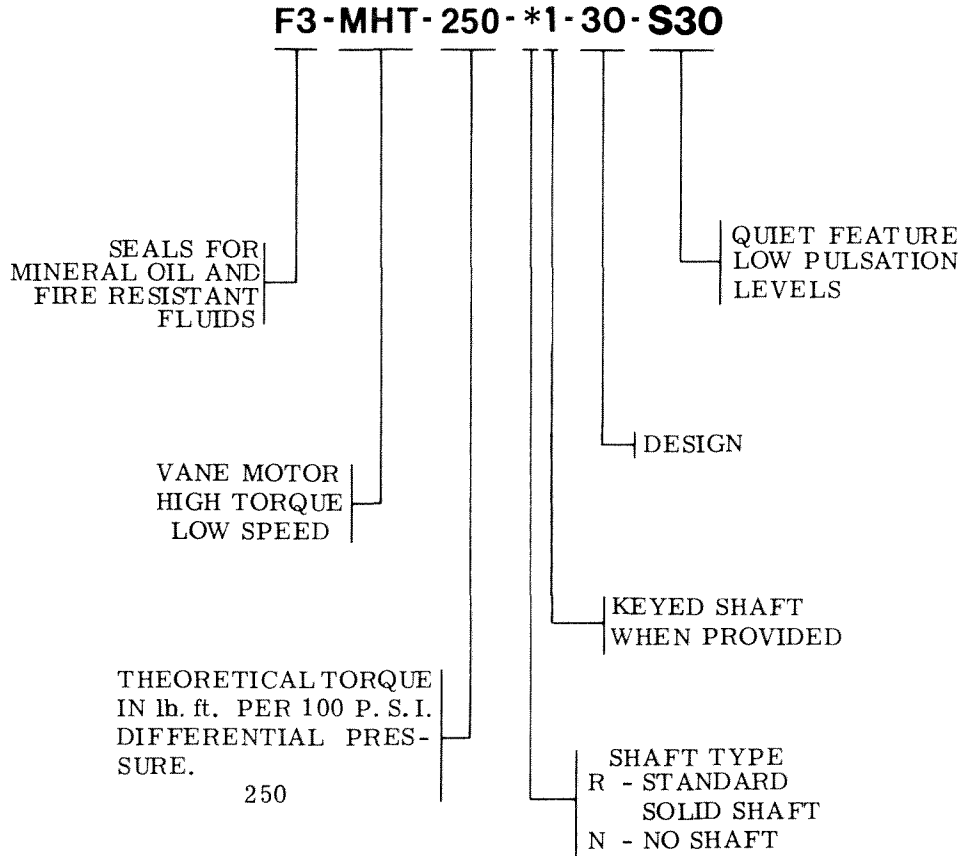

For satisfactory service life of these components, use full flow filtration to provide fluid which meets ISO cleanliness code 18/15 or cleaner. Selections from Vickers OFP, OFR, and OFRS series are recommended.