

# Service Parts Information



**HIGH TORQUE  
LOW SPEED  
VANE MOTORS**

MHT 750-\*1-30-S30

**WARNING: WEAR SAFETY GLASSES  
TO PREVENT EYE INJURY.**

**▲ INCLUDED IN  
919881 SEAL KIT**

**F3 EQUIVALENT  
SEAL KIT 919882**

**■ SLEEVES MUST BE  
.002 BELOW FACE  
.006 OF BODY.**

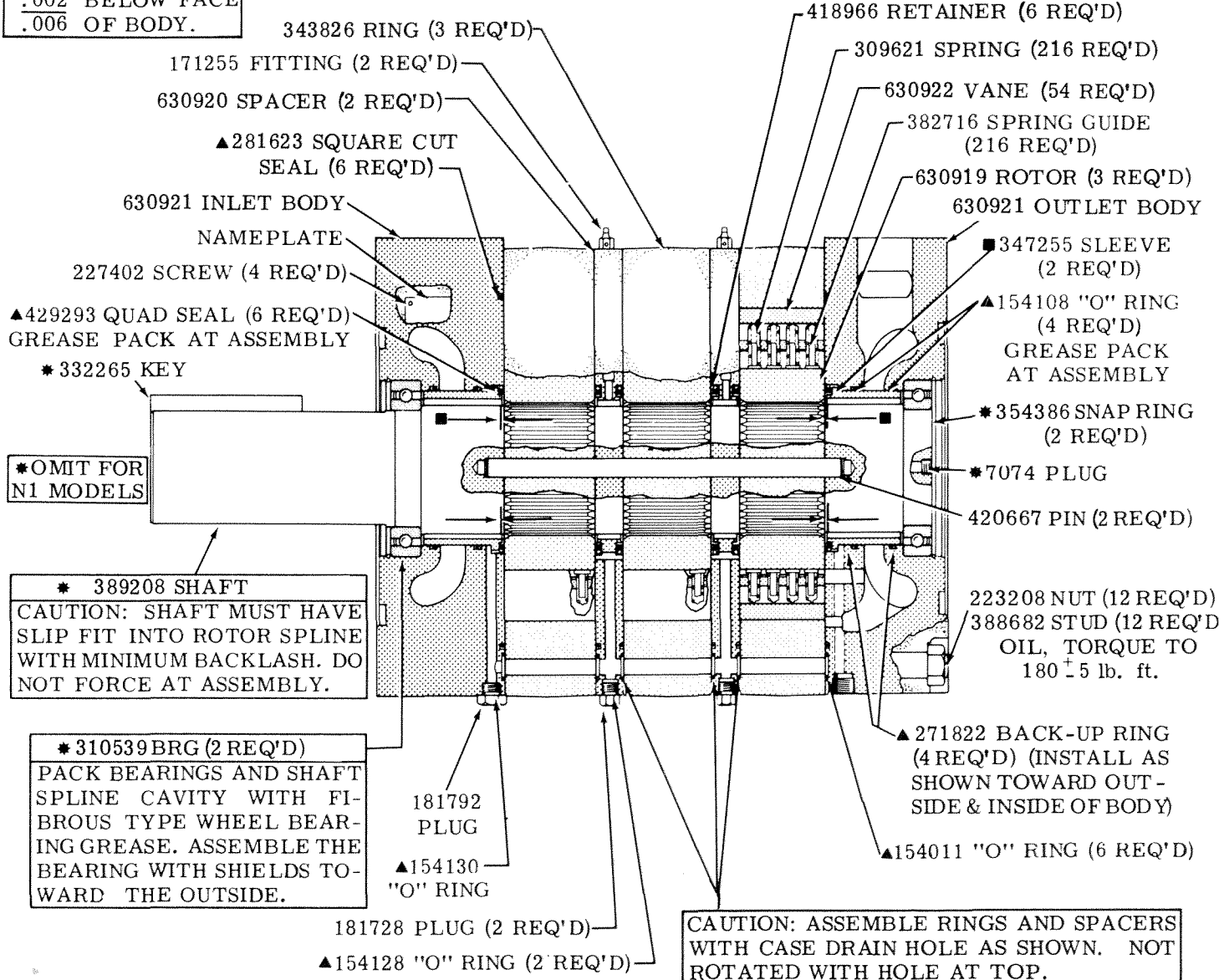

**CAUTION: WHEN ASSEMBLING CARTRIDGE, INSERT VANES IN ROTOR SLOTS AT THE MINOR DIAMETER OF CAMRING. ROTATE CARTRIDGE ONE COMPLETE REVOLUTION PRIOR TO ASSY WITH BODIES. THIS PREVENTS MISALIGNMENT OF SPRINGS AND GUIDES. MAKE SURE THE MARKED ROTOR TOOTH OF EACH CARTRIDGE IS IN LINE BEFORE INSTALLATION OF SHAFT.**

# MODEL CODE BREAKDOWN

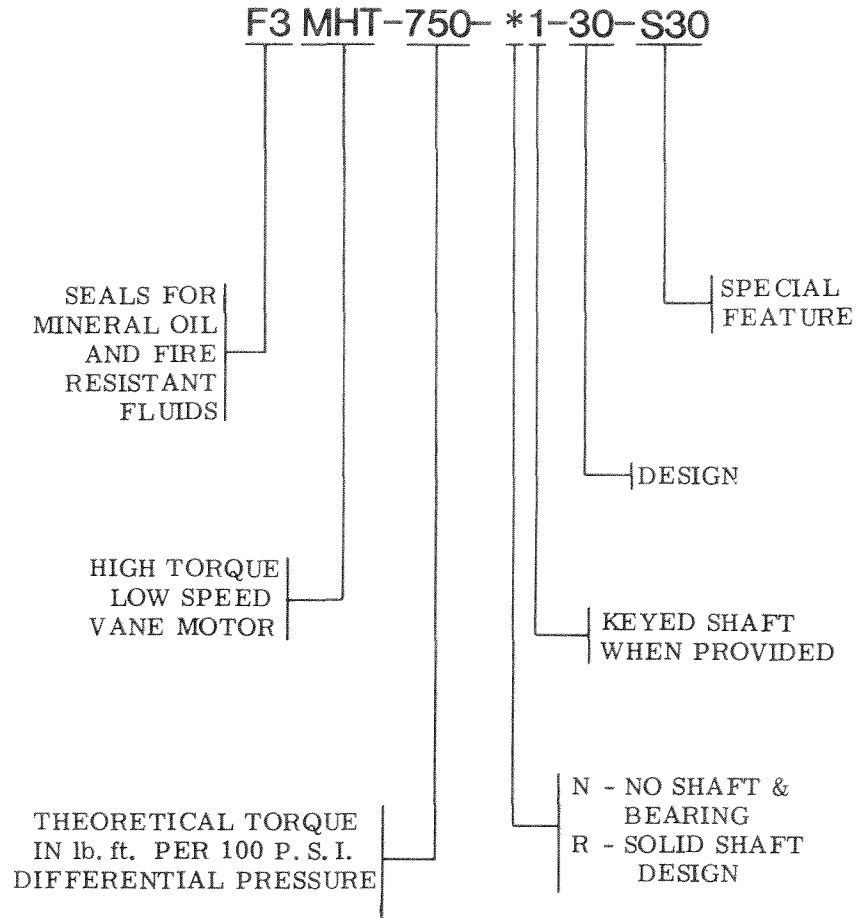

---

For satisfactory service life of these components, use full flow filtration to provide fluid which meets ISO cleanliness code 18/15 or cleaner. Selections from Vickers OFP, OFR, and OFRS series are recommended.