

Service Parts Information

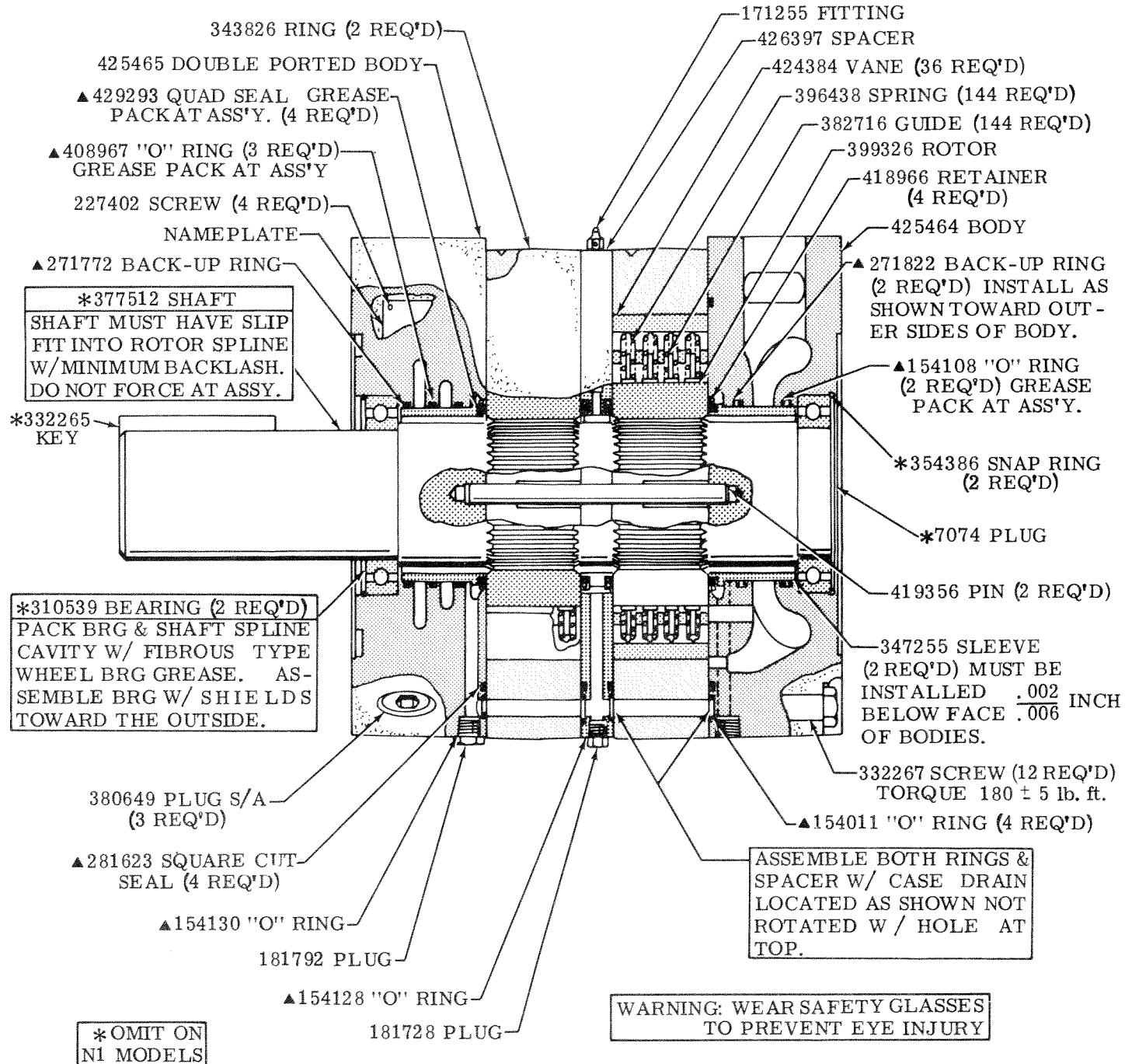

MULTI-TORQUE VANE MOTORS

MHT 500/250/250-*1-30-S27



CAUTION: WHEN ASSEMBLING CARTRIDGE, INSERT VANES IN ROTOR SLOTS AT THE MINOR DIAMETER OF CAM RING. ROTATE CARTRIDGE ONE COMPLETE REVOLUTION PRIOR TO ASSEMBLY WITH BODIES. THIS PREVENTS MISALIGNMENT OF SPRINGS AND GUIDES. MAKE SURE THE MARKED ROTOR TOOTH OF EACH CARTRIDGE IS IN LINE BEFORE INSTALLATION OF SHAFT.

MODEL CODE BREAKDOWN

F3-MHT-500/250/250-(*)1-30-S27

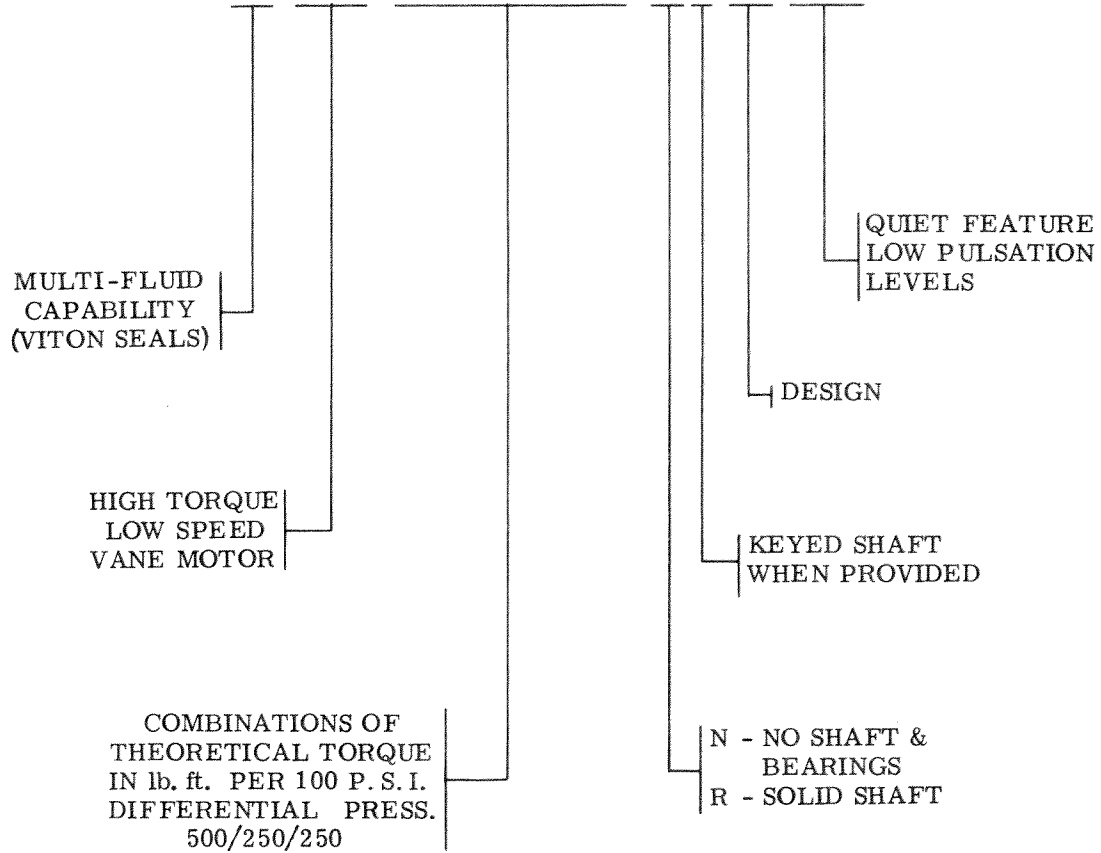

For satisfactory service life of these components, use full flow filtration to provide fluid which meets ISO cleanliness code 13/15 or cleaner. Selections from Vickers OFP, OFR, and OFRS series are recommended.