

Service Parts Information

HIGH TORQUE LOW SPEED VANE MOTORS

MODEL	SHAFT	SNAP RING	KEY	BEARING	PLUG	RING
MHT-1000-R1-30	390616	354386	332265	310539	7074 (1)	343826
MHT-1000-N1-30	—	—	—	—	378603 (2)	

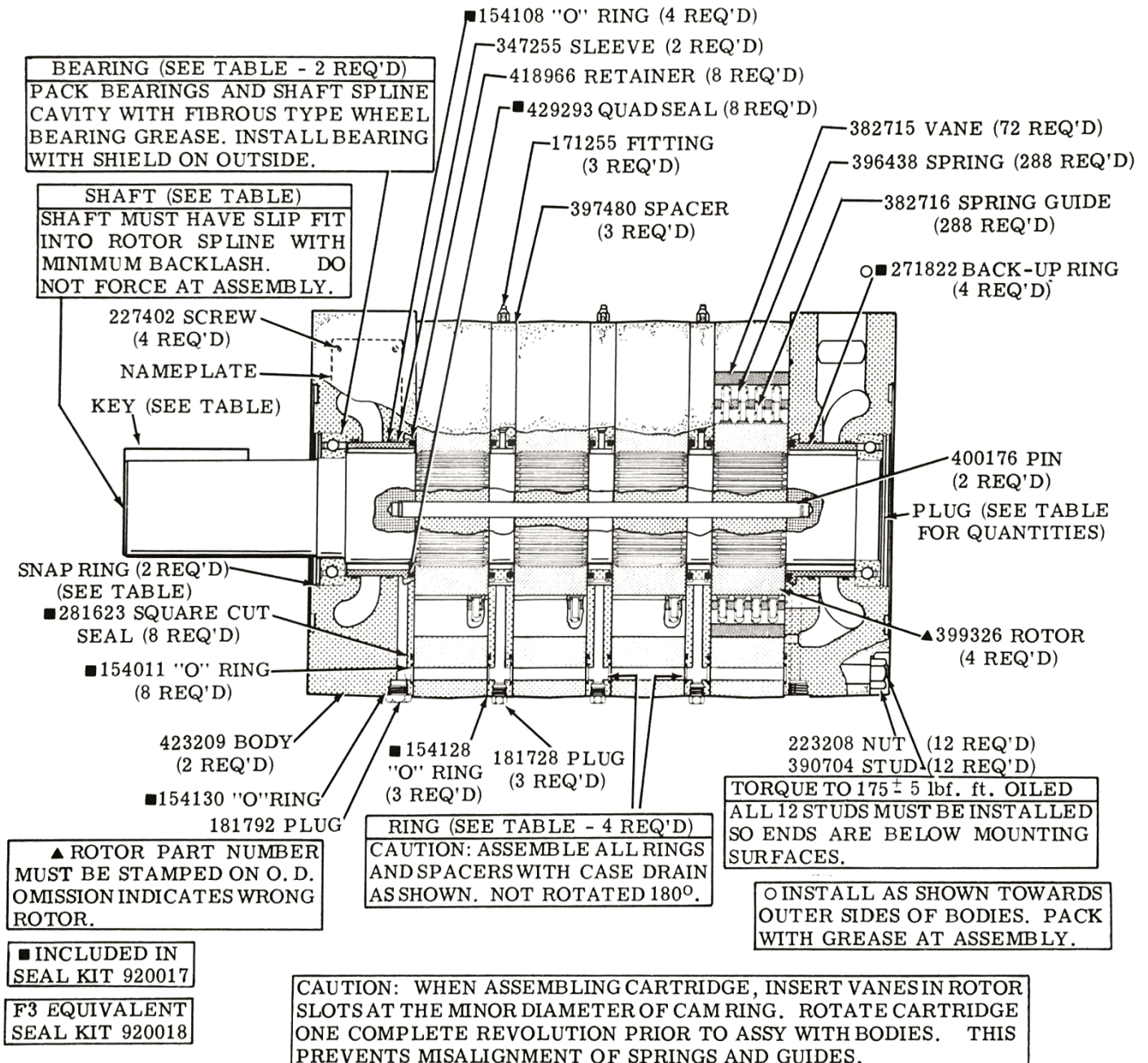

MODEL CODE BREAKDOWN

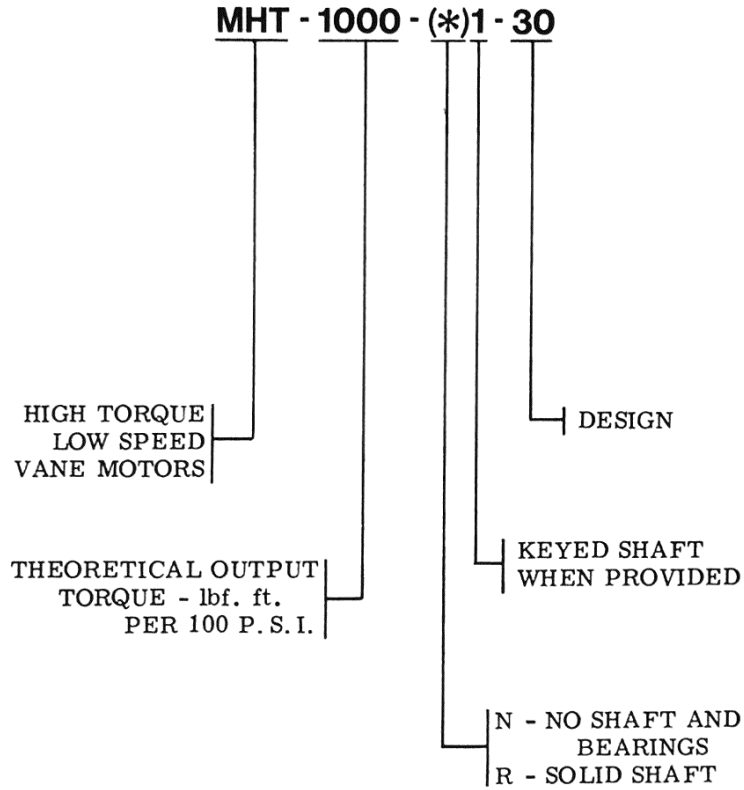

To insure sustained efficiency and maximum trouble-free life of this precision equipment, initial and continuous filtration of the fluid medium to 25 microns absolute or less is essential. (For information pertaining to Sperry Vickers economical 3 or 10 micron filters, see installation drawing 522140.)

Litho in U. S. A.