

Service Parts Information



**MULTI-TORQUE
VANE MOTORS**

MHT-190, 220 & 250

MODEL	SHAFT	SNAP RING (2 REQ'D)	RING	BEARING (2 REQ'D)	PLUG
MHT-190/95/95-*1-30	345769	354386	364468	310539	7074
MHT-220/125/95-*1-30			375223		
MHT-250/125/125-*1-30			343826		

F3 SEALKIT
919880

■ OMIT ON
N1 MODELS

▲ INCLUDED IN
919769 SEAL KIT

WHEN ASSEMBLING A MHT-220/125/95, THIS .25 DIA. HOLE IN ONE SIDE OF RING 375223 MUST FACE THE DOUBLE PORT BODY 397231.

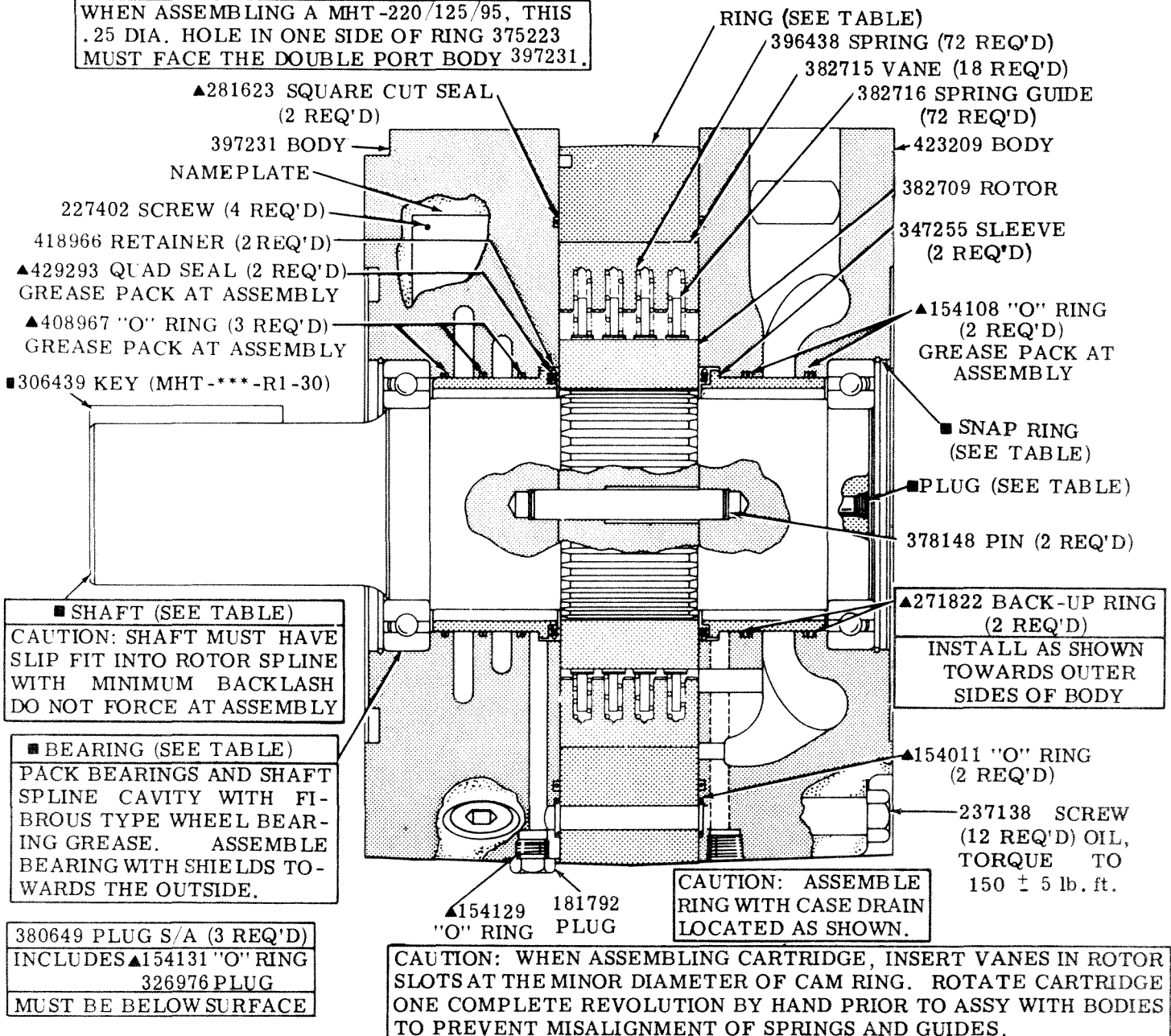

MODEL CODE BREAKDOWN

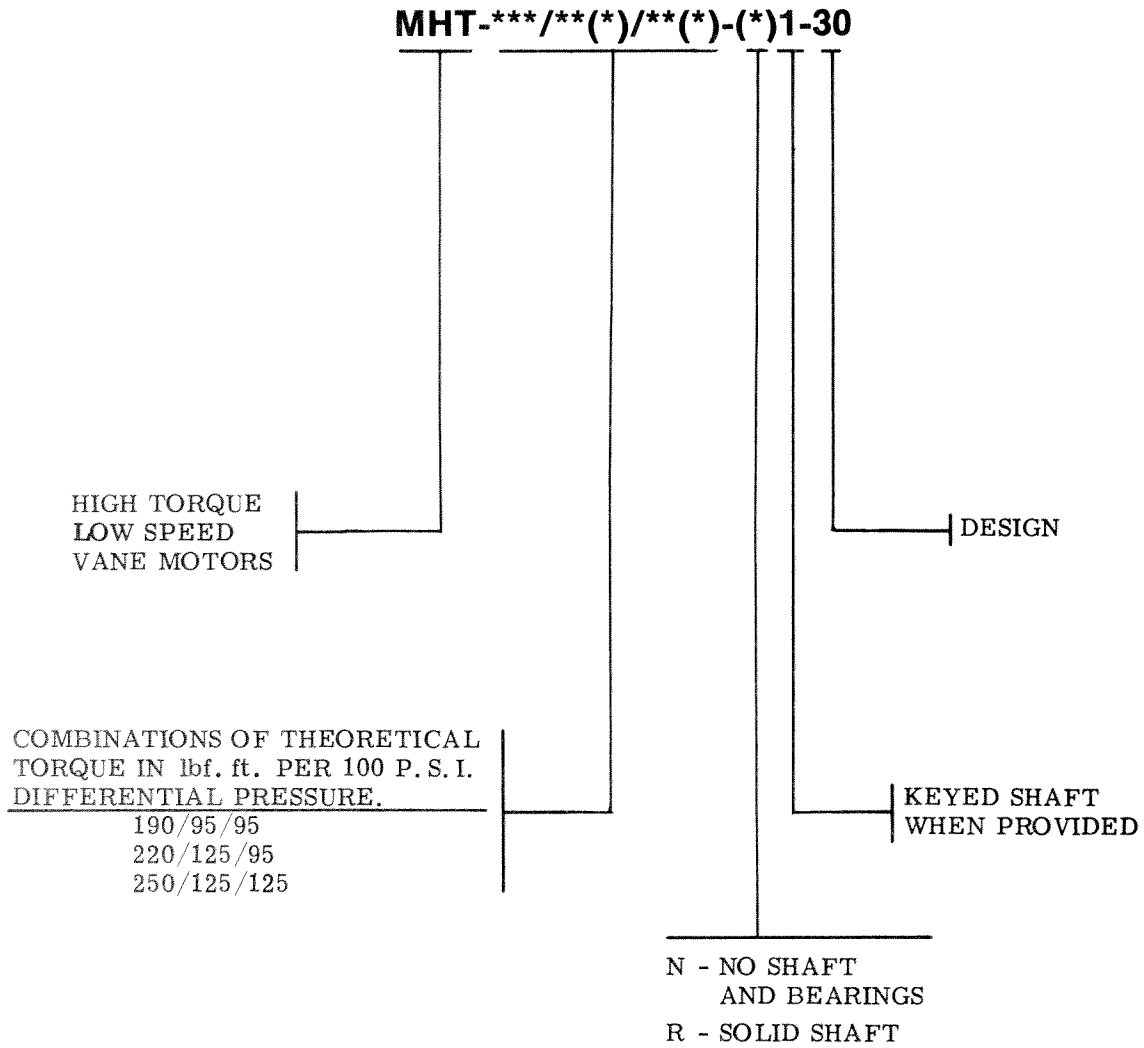

For satisfactory service life of these components in industrial applications, use full flow filtration to provide fluid which meets ISO cleanliness code 18/15 or cleaner. Selections from Vickers OFP, OFR, and OFRS series are recommended.