

 SPERRY RAND

**90 GPM VARIABLE DELIVERY  
IN-LINE PISTON PUMPS**

**VICKERS**

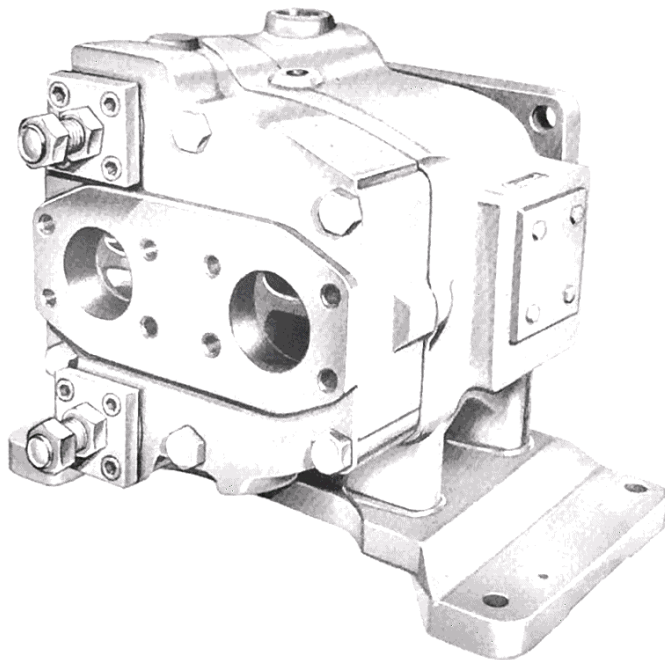

**SERVICE  
PARTS  
INFORMATION**

**PVB90-(F)RDF-20-H-10  
PVB90-(F)LDF-20-H-10**

Supersedes I-3288-S  
Rel. 1-1-69

INDUSTRIAL DIVISION  
TROY, MICHIGAN 48064

I-3291-S

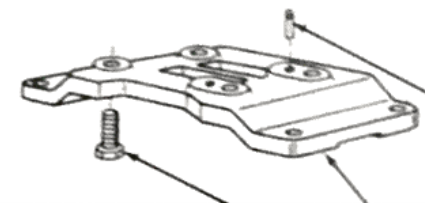

MODEL	SCREW (4 REQ'D)	BRACKET	PIN (2 REQ'D)
PVB90-(F)*DF-20-H-10	212466	279040	19089
PVB90-*DF-20-H-10	—	—	—

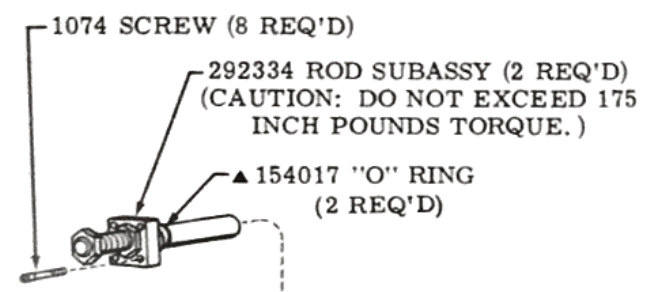

VALVE PLATE	MODEL
289225	PVB90-(F)RDF-20-H-10
292333	PVB90-(F)LDF-20-H-10

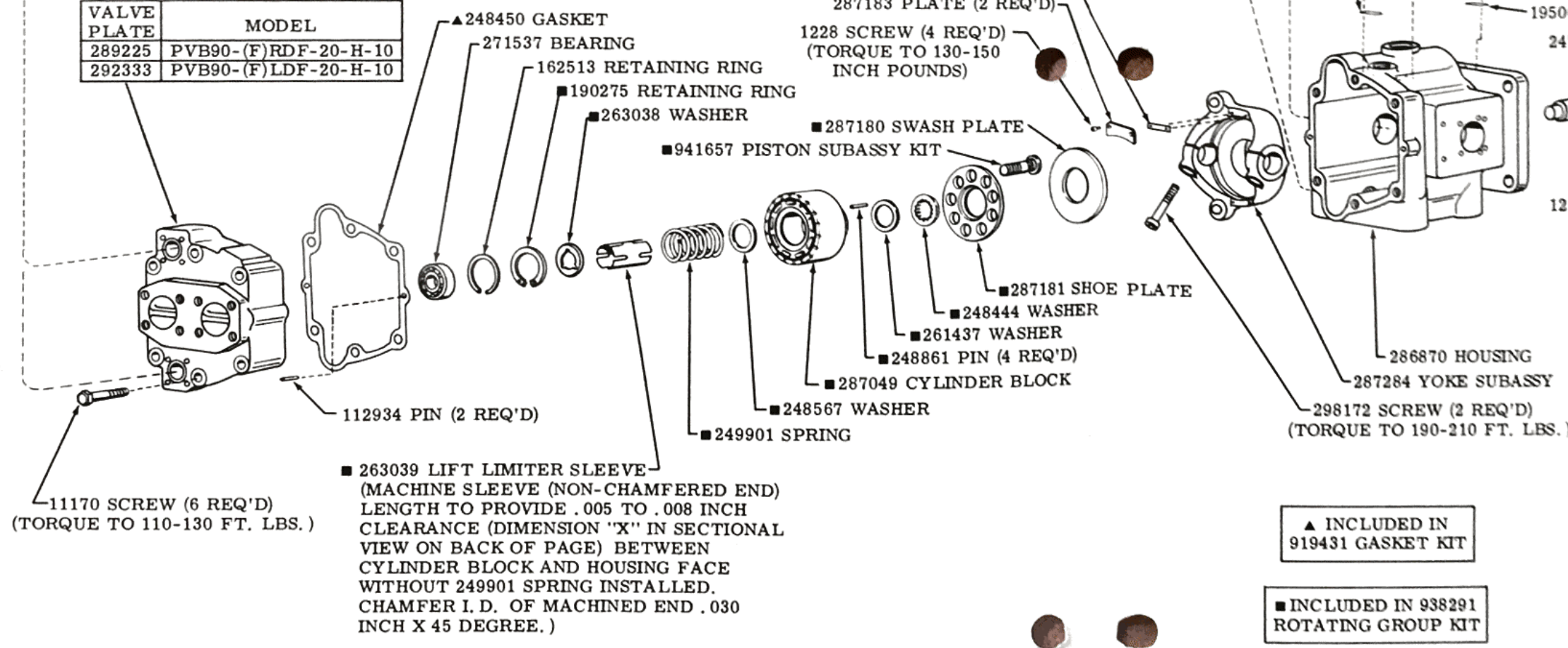

▲ INCLUDED IN 919431 GASKET KIT

■ INCLUDED IN 938291 ROTATING GROUP KIT

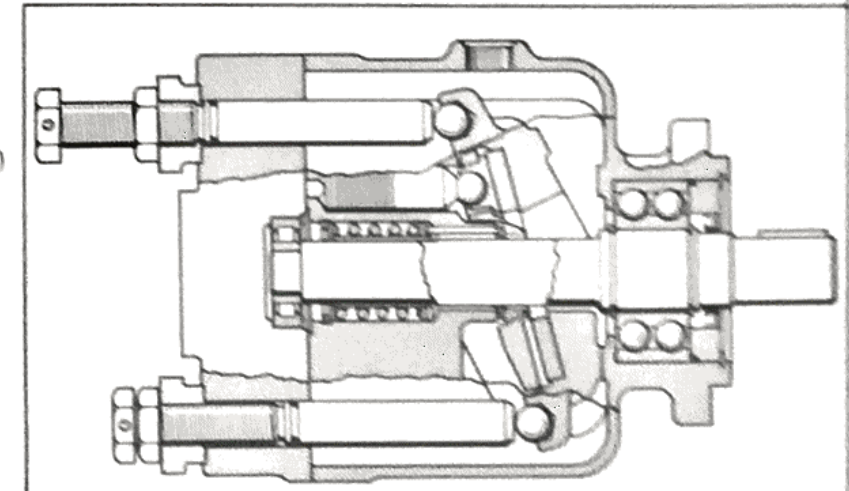

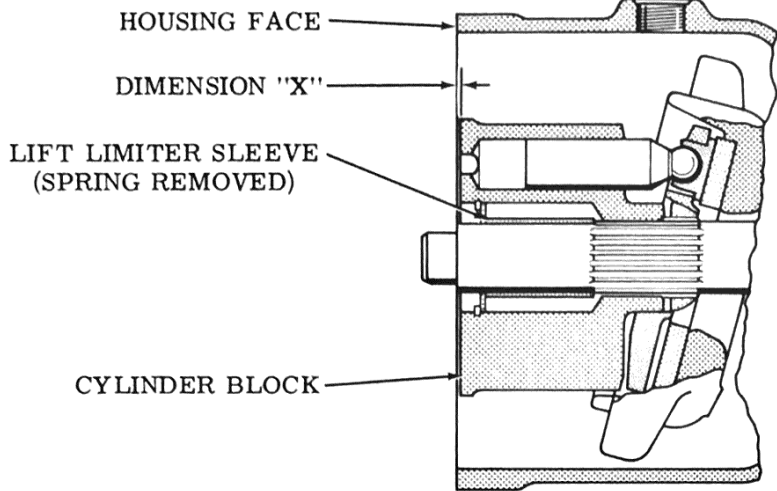

### MODEL CODE BREAKDOWN

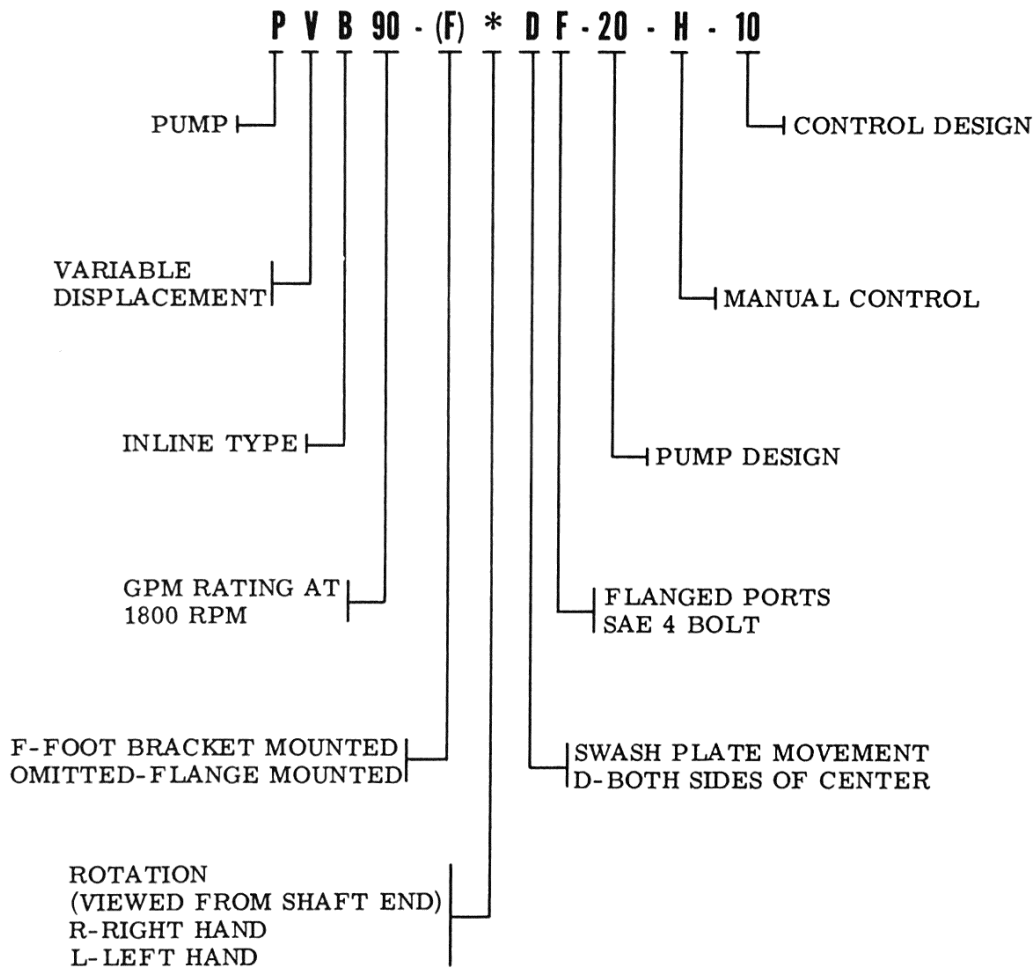

To insure sustained efficiency and maximum trouble-free life of this precision equipment, initial and continuous filtration of the fluid medium to 25 microns or less is essential. (For information pertaining to Vickers economical 10 micron filters, see installation drawing I & M 229847.)