

SPERRY VICKERS

**TRANSMISSION
PUMP**

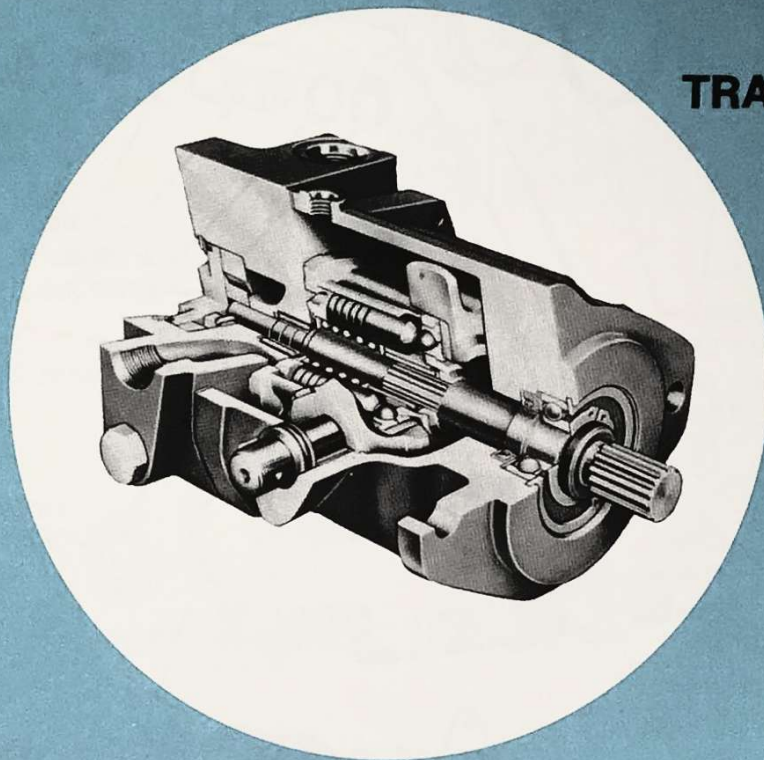

**SERVICE
PARTS
INFORMATION**

TA15 - *A* - 20(L)

SPERRY VICKERS
TROY, MI. 48084

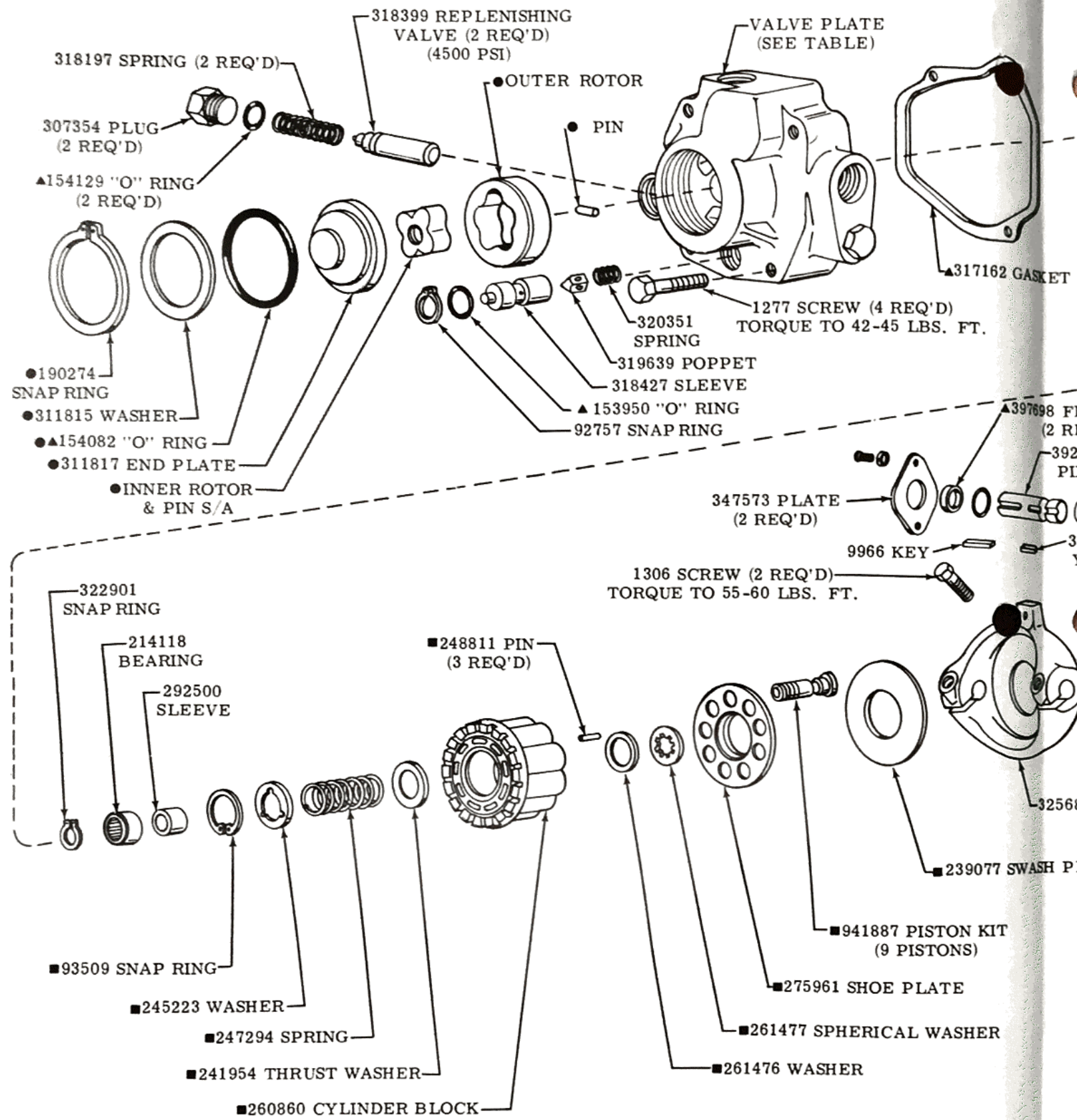

MODEL	SHAFT ROTATION	VALVE PLATE S/A (INC. 214118 BRG.)
TA15-**-20	RIGHT	923212
TA15-**-20L	LEFT	923213

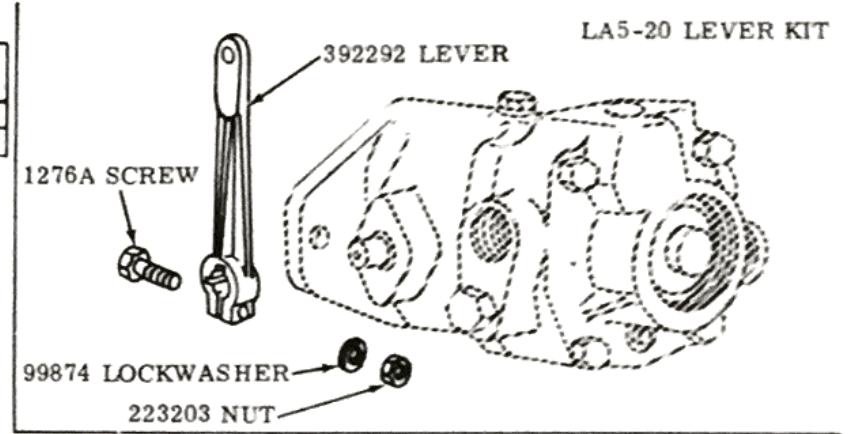

SHAFT KEY	MODEL
311819	TA15-1*-20
311806 58303	TA15-2*-20

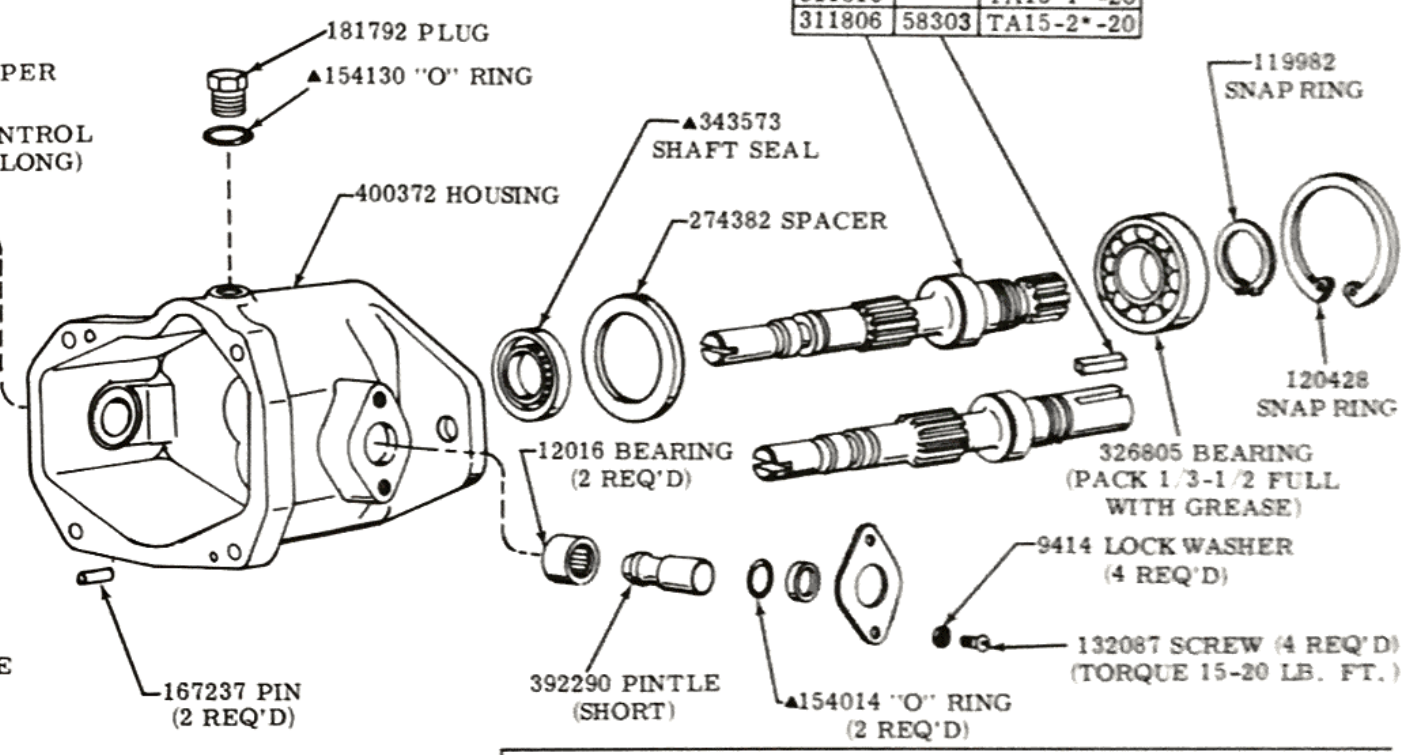

● INCLUDED IN SERVICE KIT 923379

▲ INCLUDED IN GASKET KIT 923841

■ INCLUDED IN 923062 ROTATING GROUP KIT

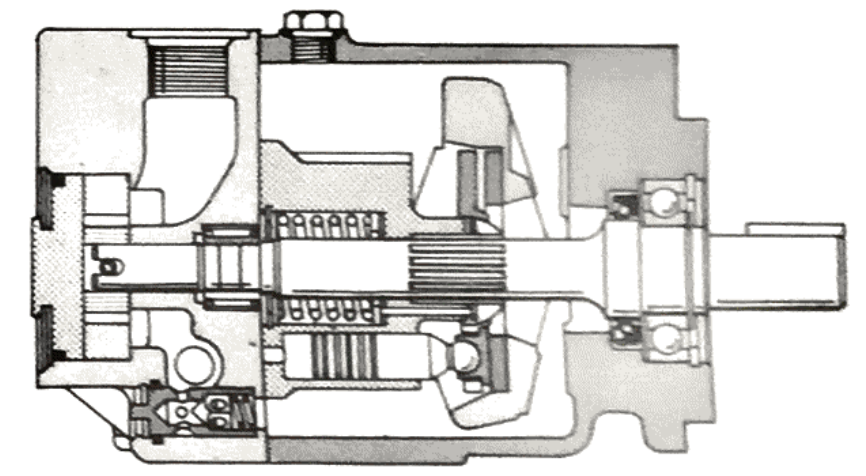

MODEL CODE BREAKDOWN

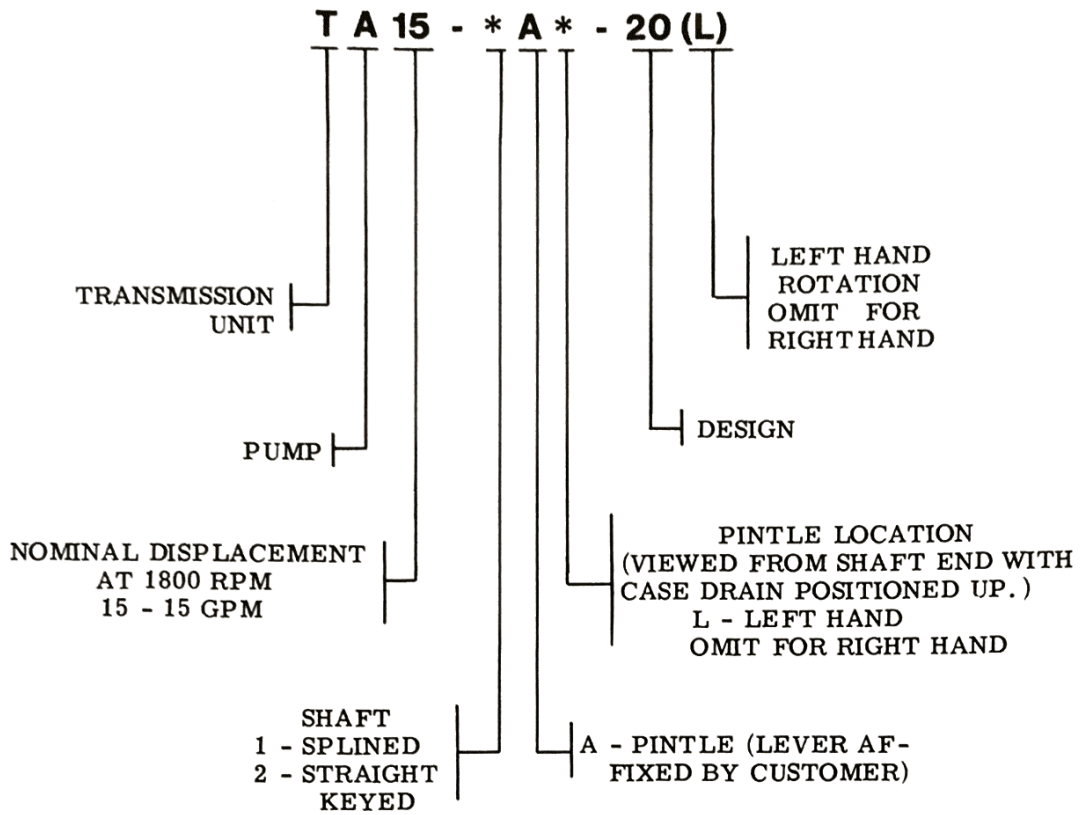

To insure sustained efficiency and maximum trouble-free life of this precision equipment, initial and continuous filtration of the fluid medium to 25 microns or less is essential. (For information pertaining to Vickers economical 10 micron filters, see installation drawing 522140.)