

VICKERS
MOBILE HYDRAULICS DIVISION
**SERVICE
PARTS
CATALOG**

 **SPERRY RAND**

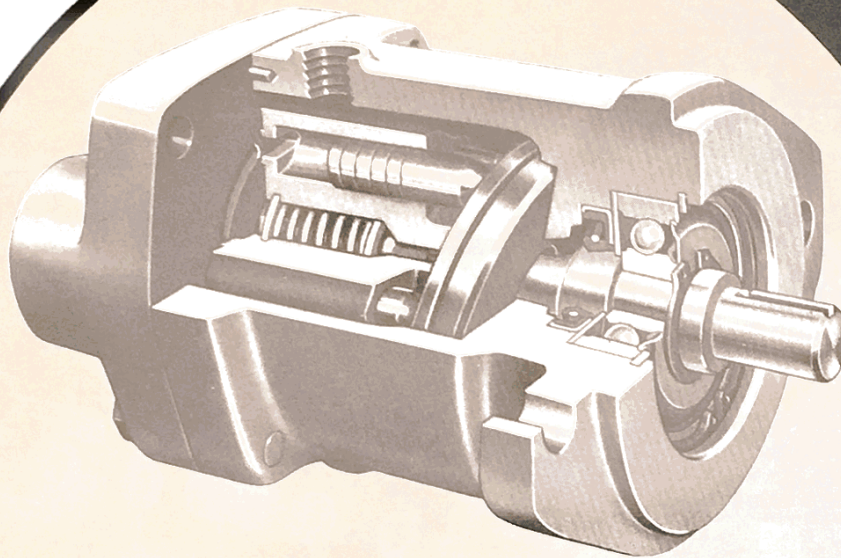

**TB15 SERIES -10 DESIGN
FIXED DISPLACEMENT
TRANSMISSION MOTORS**

VICKERS DIVISION
TROY, MICHIGAN 48084

MODEL CODE

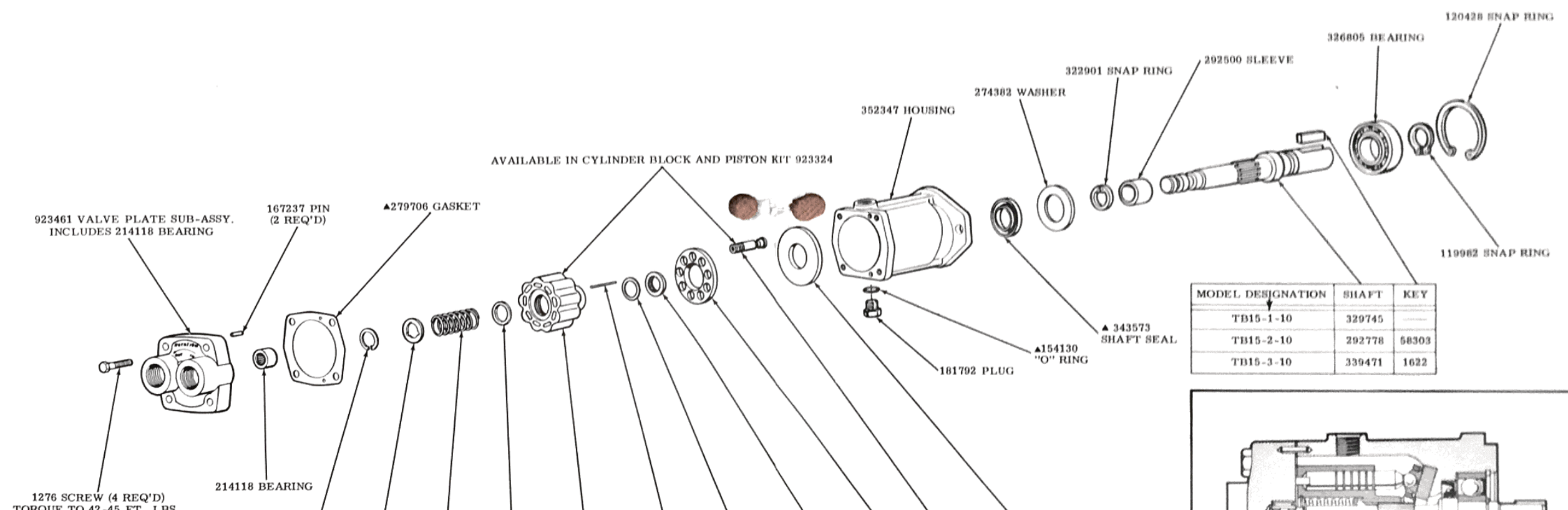
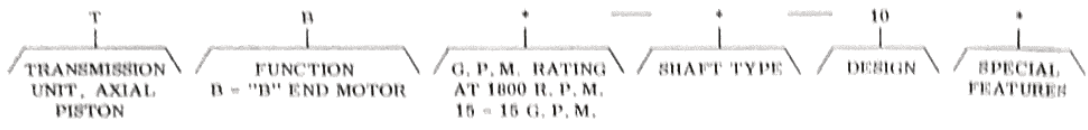

MODEL DESIGNATION	SHAFT	KEY
TB15-1-10	329745	—
TB15-2-10	292778	58303
TB15-3-10	339471	1622

SNAP RING	LIFT LIMITER	SPRING	THRUST WASHER	CYLINDER BLOCK	PIN (3 REQ'D)	WASHER	SPHERICAL WASHER	SHOE PLATE	PISTON S. A. (9 PISTONS)	SWASH PLATE
← SERVICED IN ROTATING GROUP KIT 923460 →										

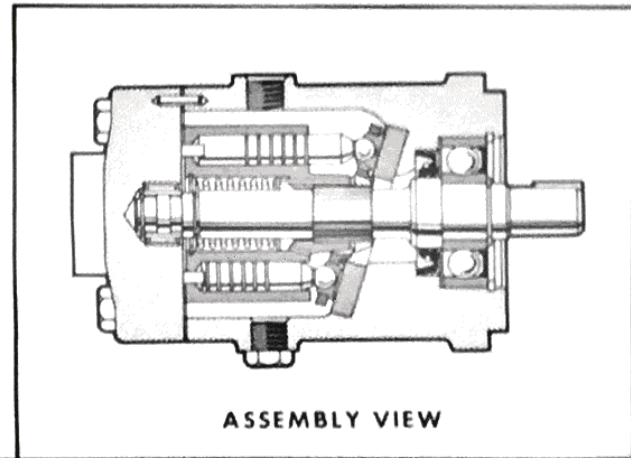

▲ - SERVICED IN 923459 SEAL KIT

1 INCLUDE COMPLETE MODEL NUMBER ON ALL PARTS ORDERS

2

SPARE PARTS STOCK RECOMMENDATIONS (FOR EACH 100 UNITS IN OPERATION)

PART NUMBER	NAME	TB				QUANTITY PER UNIT	QUANTITY RECOMMENDED FOR STOCK
		G. P. M. RATING	SHAFT TYPE	DESIGN	SPECIAL FEATURES		
1276	SCREW					4	10
923461	VALVE PLATE					1	15
167237	PIN					2	10
214118	BEARING					1	7
923324	CYL. BLOCK KIT	15				1	15
923460	ROTATING GROUP KIT	15				1	15
181792	PLUG					1	2
352347	HOUSING					1	2
274382	WASHER					1	5
322901	SNAP RING					1	10
292500	SLEEVE					1	10
329745	SHAFT		1			1	7
292778	SHAFT		2			1	7
339471	SHAFT		3			1	7
58303	KEY		2			1	7
1622	KEY		3			1	7
326805	BEARING					1	7
114482	SNAP RING					1	10
120428	SNAP RING					1	10
923459	SEAL KIT					1	25

CONTACT VICKERS APPLICATION ENGINEER FOR SPECIAL FEATURE INFORMATION

To insure sustained efficiency and maximum trouble-free life of this precision equipment, initial and continuous filtration of the fluid medium to 25 microns or less is essential. For information pertaining to Vickers economical 10 micron filters, see installation drawing M-229847.