

VICKERS
MOBILE HYDRAULICS DIVISION
**SERVICE
PARTS
CATALOG**

 **SPERRY RAND**

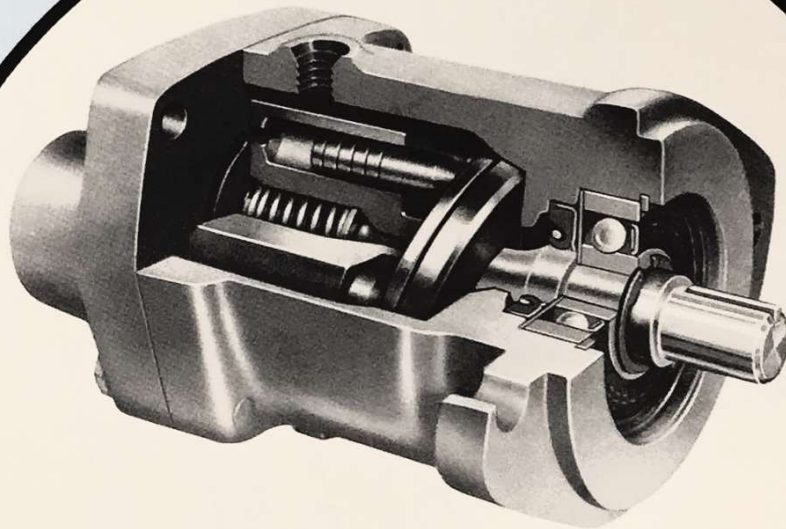

**M-MFB10 AND M-MFB15-30
DESIGN FIXED IN-LINE
PISTON MOTORS**

VICKERS DIVISION
TROY, MICHIGAN 48084

FOOT MOUNTING BRACKET
 MODEL M-MFB*-F**-20

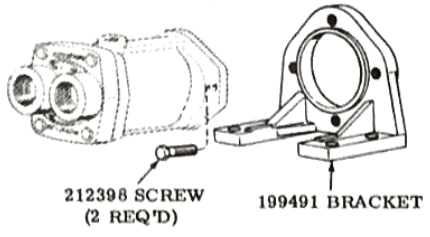

MODEL DESIGNATION	VALVE PLATE SUB-ASSY. INCLUDES 12016 BEARING
M-MFB10-U*-30	941050
M-MFB15-U*-30	922995

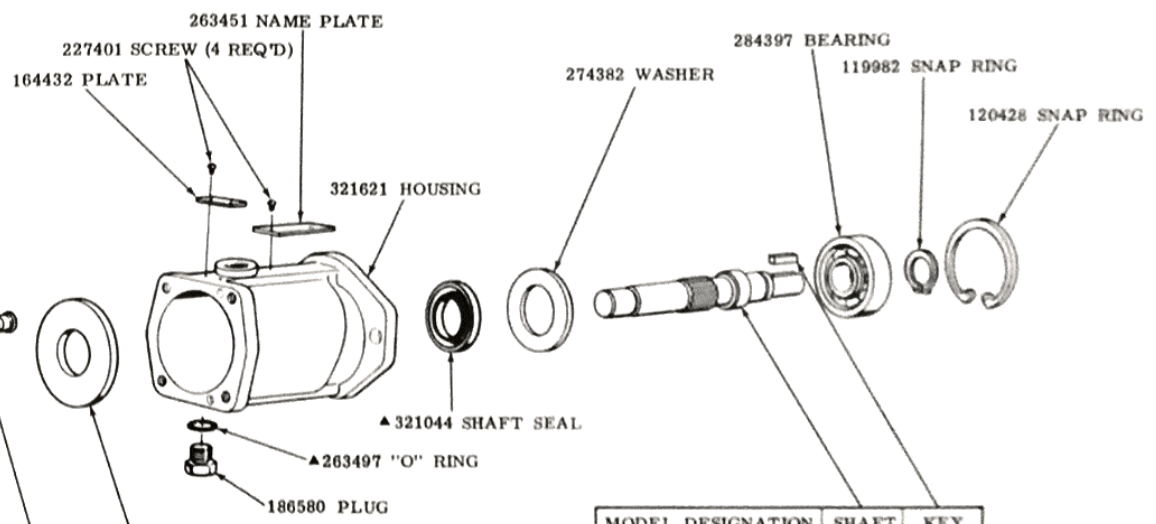
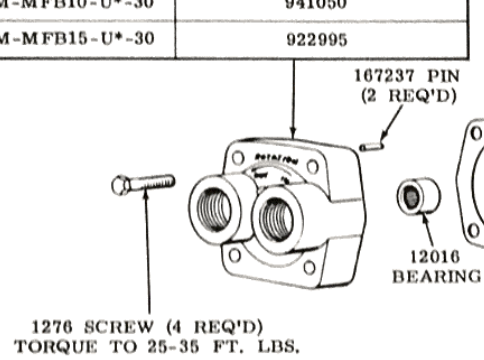

MODEL DESIGNATION	SHAFT	KEY
M-MFB*-U-30	261552	22971
M-MFB*-UY-30	270370	58303
M-MFB*-UG-30	295729	—

13 TOOTH SPLINE

MODEL DESIGNATION	SNAP RING	LIFT LIMITER	SPRING	THRUST WASHER	CYLINDER BLOCK	PIN (3 REQ'D)	WASHER	SPHERICAL WASHER	SHOE PLATE	PISTON KIT (9 PISTONS)	SWASH PLATE	ROTATING GROUP KIT
	THESE PARTS ARE SERVICED IN ROTATING GROUP KIT											
M-MFB10-*-30	93509	245223	247294	241954	321703	248811	261476	284380	275961	942047	239077	938272
M-MFB15-*-30					320181					923190		922996

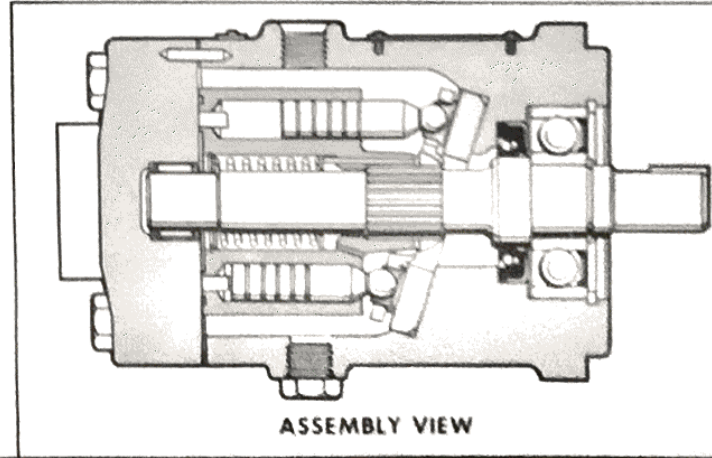

▲ = SERVICED IN 910521 SEAL KIT

SPARE PARTS STOCK RECOMMENDATIONS (FOR EACH 100 UNITS IN OPERATION)

PART NUMBER	NAME	M-MFB					SPECIAL FEATURES	QUANTITY PER UNIT	QUANTITY RECOMMENDED FOR STOCK
		G. P. M. RATING	ROTATION	SHAFT TYPE	DESIGN				
1276	SCREW						4	10	
SEE PAGE 1	VALVE PLATE S. A.	10, 15	U				1	15	
167237	PIN						2	10	
12016	BEARING						1	7	
93509	SNAP RING	10, 15					• 1	15	
245223	LIFT LIMITER	10, 15					• 1	15	
247294	SPRING	10, 15					• 1	10	
241954	WASHER	10, 15					• 1	15	
SEE PAGE 1	CYLINDER BLOCK	10, 15					• 1	15	
248811	PIN	10, 15					• 3	10	
261476	WASHER	10, 15					• 1	10	
284380	WASHER	10, 15					• 1	10	
275961	PLATE	10, 15					• 1	15	
SEE PAGE 2	PISTON KIT (9 PISTONS)	10, 15					• 1	15	
239077	SWASH PLATE	10, 15					• 1	15	
SEE PAGE 2	ROTATING GROUP KIT	10, 15					1	15	
186580	PLUG						1	2	
321621	HOUSING						1	2	
164432	PLATE						1	2	
227401	SCREW						4	2	
263451	NAME PLATE						1	2	
274382	WASHER						1	5	
SEE PAGE 2	SHAFT			Y, G			1	7	
SEE PAGE 2	KEY			Y			1	7	
284397	BEARING						1	7	
119982	SNAP RING						1	10	
120428	SNAP RING						1	10	
919521	SEAL KIT						1	25	

CONTACT VICKERS APPLICATION ENGINEER FOR SPECIAL FEATURE INFORMATION

• MAY BE PURCHASED IN ROTATING GROUP KIT

To insure sustained efficiency and maximum trouble-free life of this precision equipment, initial and continuous filtration of the fluid medium to 25 microns or less is essential. For information pertaining to Vickers economical 10 micron filters, see installation drawing M 229847.